

**Accident Prevention Plan and Safety Information:
Borehole Monitoring Capability
Above Legacy Salt Caverns
at VigIndustries/Mosaic Hutchinson Facility**

Kansas Geological Survey Exploration Services

*Kansas Geological Survey Open-File Report No. 2026-2
April 2026*

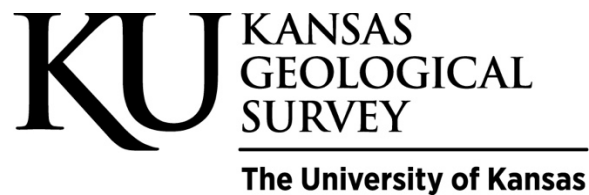

1930 Constant Ave., Lawrence, KS 66047 (785) 864-3965; www.kgs.ku.edu

**KANSAS GEOLOGICAL SURVEY
EXPLORATION SERVICES
ACCIDENT PREVENTION
PLAN**

I. PROJECT DESCRIPTION

Project Name:

**Borehole Installation and Monitoring for Event Detection Capability Above Legacy Salt Caverns at
Vigindustries/Mosaic's Hutchinson, Kansas Facility**

Location: Hutchinson, Kansas

KGS Safety Officer: Richard D. Miller

Plan Prepared by: Richard D. Miller

Estimated Duration of Field Work: 3 days

PHASE 1

Borehole Cable and Sensors

The sensor array will consist of 18 pods molded into a single cable with 15, single component (1C-compressional) and 3, three component (3C-compressional and shear) configurations (figure 1). Individual pods will be separated by 13 feet starting 130 feet below ground surface. The cable will terminate at the surface with an industry standard Bendix style connector. The sensors will be a Sensor product with a natural frequency of between 25 Hz and 30 Hz and internal coil impedance of at least 1500 Ohms. To ensure compatibility between different sensor orientations (3 components) the sensors will be omni directional so the same sensors can be used for both compressional and shear orientations.

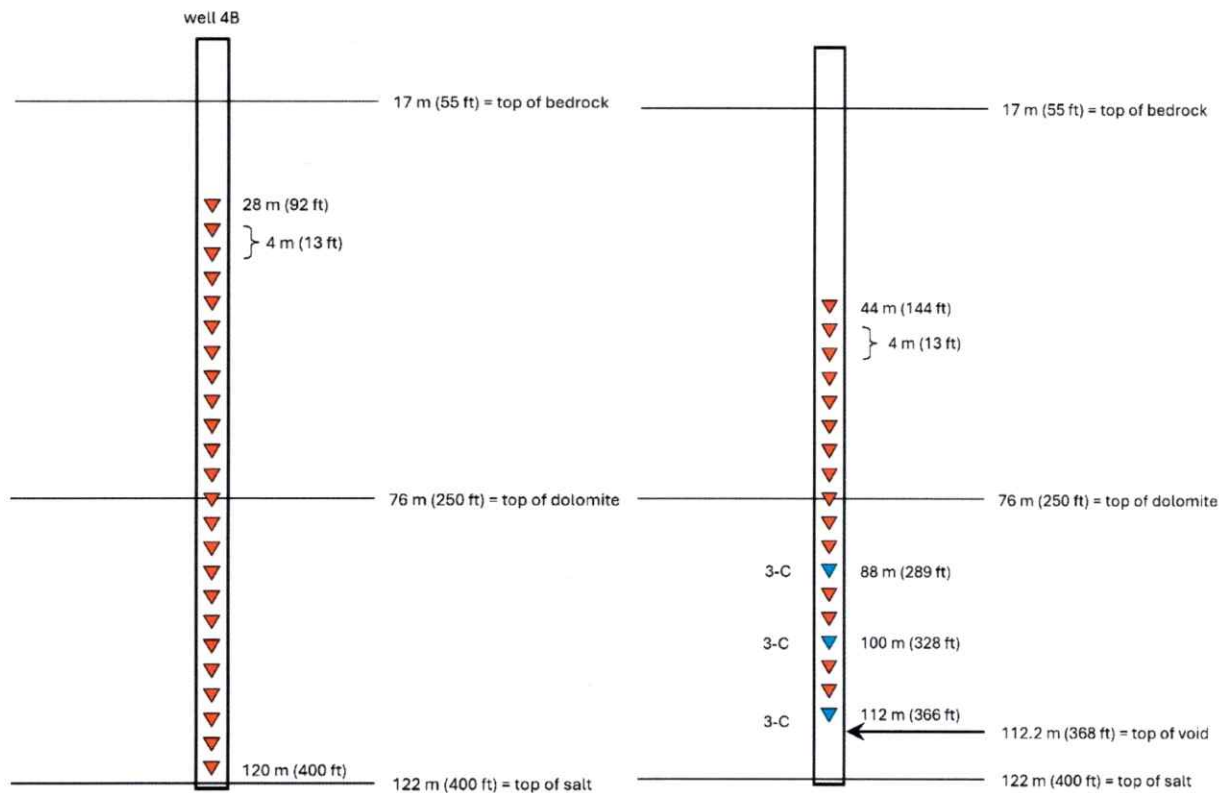

Figure 1. Relative location of sensors in well 4B (left) and 5B (right) correlated with major lithologic units. Blue triangles (only in 5B) are 3C pods and red triangles are the locations of 1C pods. The pods will be integral to a single neoprene cable cemented in the well to optimize coupling.

Acquisition

Prior to installation of borehole sensor array a zero offset velocity survey (ZOV) will be conducted in both well 4B and 5B prior to cable installation (figure 2). The ZOV will be acquired using two sources, one vertically polarized and one horizontally oriented with shot stations at distances of around 6'-10' from the wellbore (as close as possible without the need to couple with soil disturbed from drilling). The downhole receiver will be a three-component (3-C) Geostuff BHG-2 geophone with steel band clamping mechanism. The natural frequency of the sensors is 10 hertz (Hz). Receiver stations will be located in the borehole from 20-360 ft below ground surface at 10 ft intervals. Multiple consecutive shots (three to six, depending on depth) will be recorded independently for each of the 5-source impact directions (N/S, S/N, E/W, W/E, and vertical) and then vertically stacked during processing to improve the signal-to-noise ratio. The three unique source locations will be occupied at 0, 120, 240 degrees relative to the borehole. Data from this survey will be used to establish a 3C velocity function for determining directionality of energy impinging on the borehole sensor spread.

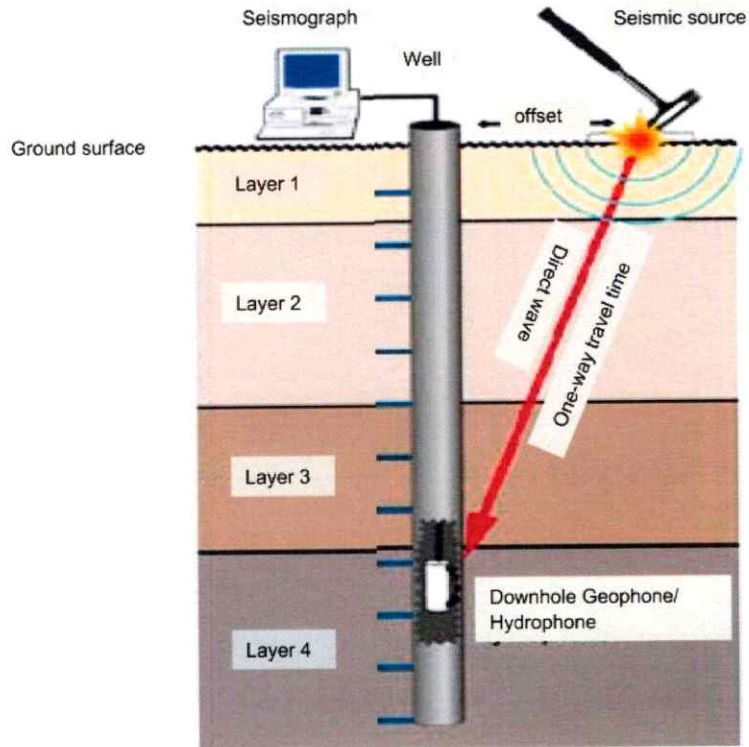

Figure 2. Diagram of downhole velocity survey. For the application referenced in this proposal the offset would be as close to the borehole as possible and likely around 10 feet. Ideal is zero offset but with ground disturbed by drilling, ideal is not possible.

Installation

A borehole crew (contracted by TRC and with guidance from KGS) will install the sensor cable by attaching the cable at 10' intervals to tremie pipe while lowered in the two wells in sections. Once the pipe is fully deployed in the borehole with geophones attached a continuity test will be run on the cable. Once the test confirms all sensors are functioning as designed cement will be pumped into the pipe exiting into the borehole at the bottom and flowing upwards to within 1 ft of the top of the pipe. Cement needs to be pumped into the well at a relatively slow rate to avoid dislodging the cable from the pipe.

Well casing should terminate around 1' below ground surface so vault lid is at ground surface grade and cabling exiting the top of the well casing can remain fully inside the vault with plenty of head space between well and vault lid to avoid kinking cables. Well casing annular space between bedrock and 3' below ground surface should be filled and well packed to allow solid footing for vault base. A 3' x 2' x 3' vault will be installed with the well head inside the vault leaving room for seismic instrument box and fiber connector panel (figure 3). The vault lid will be secured to the vault to protect from inadvertent encroachment by rodents, wildlife, or vehicles (<5,000 lbs).

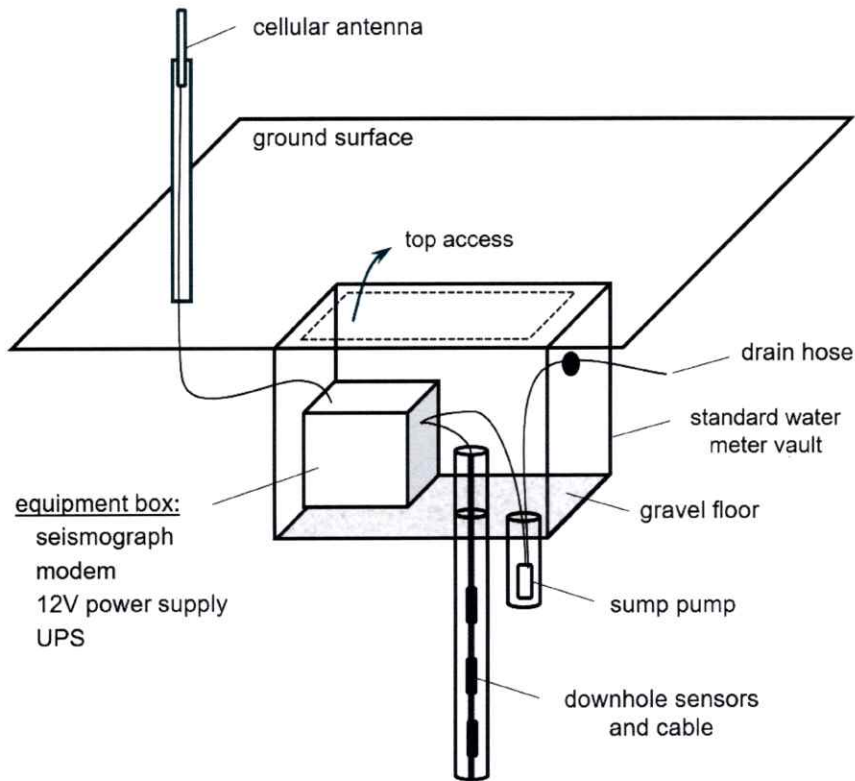

Figure 3. Generalized diagram representative of configuration and relative placement of vault containing recording instruments, power supplies, and drainage sump. The fiber distribution box will be mounted in the vault to one of the long axis walls. Power will be available inside the vault from 110 V outlets.

Power drops will be made inside the vault through 4 standard 110 V outlets. Two 20-amp circuits will be available inside the vault, each with a standard 110 V GFP outlet. The vault will be installed without instrumentation and made available to Burns and McDonnell for installation of the 110 V power distribution box. Once the power is available inside the vault, all the seismic instrumentation will be installed and system brought to operational status. All electrical work will be the responsibility of a licensed contractor familiar with local code. Ideally, power will enter the box through a watertight orifice and then available inside vault through mounted outlets.

A ground flush vault style installation will provide maximum protection for equipment and minimize the impact on surface activities (figure 3). The vault will be installed after the sensors have been placed and cemented in the borehole. Equipment and components in the vault will include:

- Seismic Source Inc GeoDAQ4 seismograph,
- 12V power supply,
- UPS,
- Modem,
- Control console, and
- Sump pump.

Note: Space will be available for sidewall installation of fiber control panel (2' x 2' x 6"). Additionally, a cell mast will be located within 50 ft of the vault and in a location that minimizes potential for inadvertent contact.

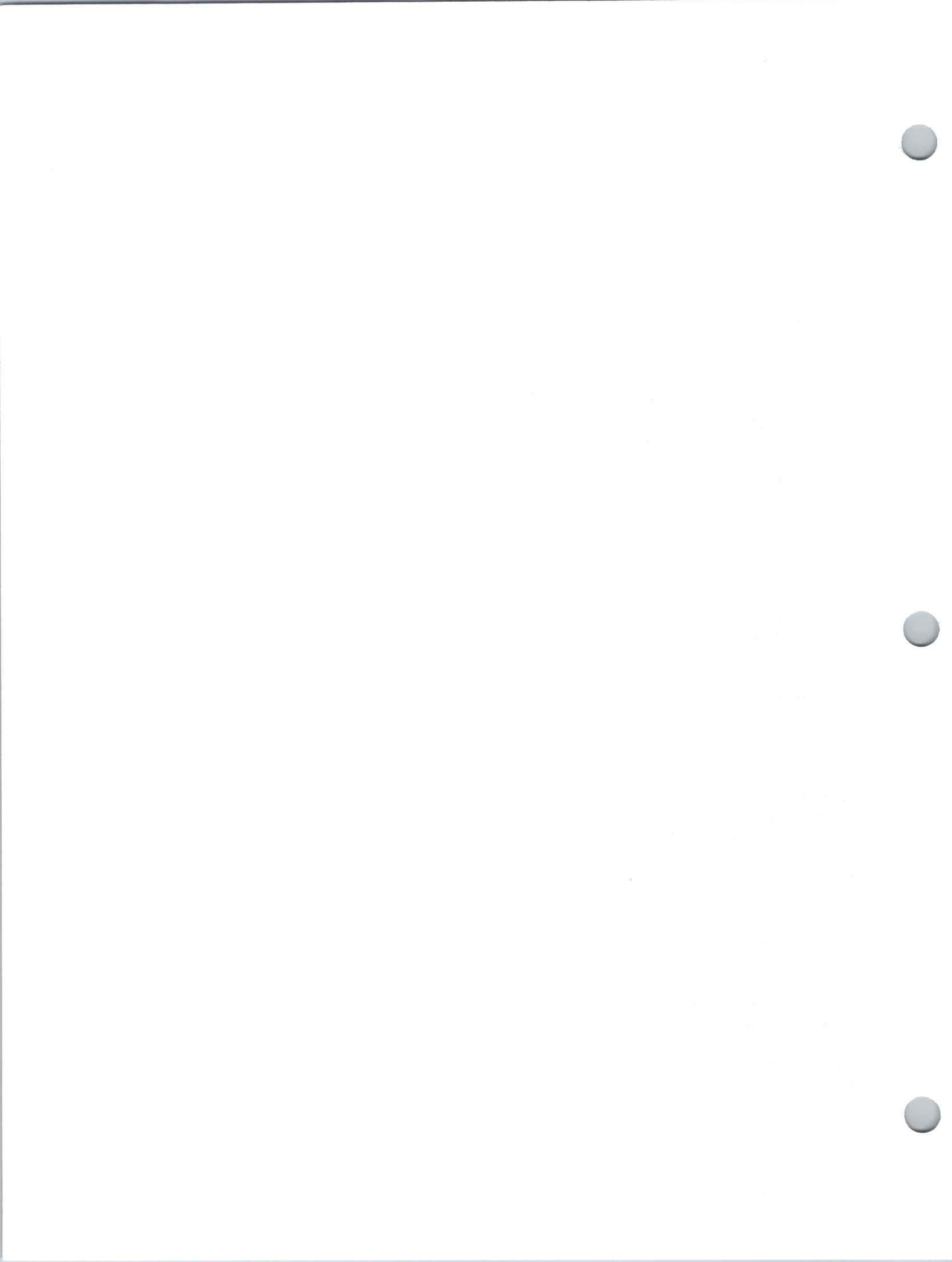

I. RESPONSIBILITIES

The responsibility for providing each employee with a safe working environment rests with each employee's respective employer. This plan, therefore, applies only to KGS for the survey activities. Each employee of KGS will strive to identify and mitigate any safety hazards encountered. All parties will cooperate in working as safely as possible and will comply with all applicable safety requirements as set forth by KU and KGS as well as those included in this document.

In addition to the specific safety procedures indicated herein, we will adhere to the following:

1. In the event of electrical storms in the vicinity, all surface operations will cease if lightning strikes are closer than three miles (determined by 15 second count between lightning and thunder and/or by lightning detector).
2. If conditions become excessive (i.e., temperature $> 100^{\circ} < 30^{\circ}$ F), continuous day operations may be modified to minimize the chances for heat- or cold-related medical problems. Breaks of up to one hour after every hour of work might be necessary in extreme situations (i.e., temperature $> 110^{\circ} < 0^{\circ}$ F). Maximum hydration of staff will be strived for at all times.
3. Appropriate field boots will be worn, and due caution will be exercised with respect to snakes, ditches, swampy areas, and ground debris. Steel toes will be worn by all field crew members.
4. Safety glasses will be worn by crew members when operating open-air vehicles or sources. Safety glasses are recommended when planting geophones.
5. At least one gallon of fresh water will be on hand at the beginning of each day for each crew member. An ice chest for keeping foodstuff cold and an ice chest for medical use in case of injury or overheating will be available on-site.
6. In the case of excessive cold weather, a sheltered area will be available with inside temperatures above 32° F.
7. The seismic crew will operate with an established protocol for initiating seismic sources. The safety plan will be approved by the KU and KGS Representative prior to initiation of field operations.
8. Appropriate driver's licenses will be held by operators of vehicles at all times (KDOT regulations). All KGS staff will have appropriate utility vehicle (UTV) training. All vehicles will be operated in accordance with manufacturer's documented procedures.
9. All explosive or flammable materials will be properly stored in vehicles and labeled in accordance with KDOT regulations during transport. MSDSs will be in this safety plan for all regulated, controlled, or potentially hazardous materials.
10. High pressure systems will be identified and will be maintained to meet or exceed manufacturer's specifications.

11. Work along roads will comply with regulations as established by KDOT (in Kansas) or local department of transportation (for out-of-state).
12. Proper work gloves and clothing for site conditions will be worn by all KGS staff.
13. High visibility clothing or KDOT approved reflective vests will be worn on work site.
14. Hard hats will be available when needed to complete duties
15. Defibrillator will be available at field site.
16. Each vehicle will have first aid kits and hearing protection available in storage boxes.
17. A range of work gloves will be available on-site.
18. All field staff will have access to handheld radios for 100% communication with team members.
19. All on-site vehicle operations will be undertaken safely with speeds not to exceed 20 mph and spotters for all blind spots.
20. Morning or start of field activity safety meetings will be held each day. All hazards and plans for the day are discussed and past day's activities reviewed.
21. All field crew members participate voluntarily in field work, with field conduct and expectations well defined and explained prior to departure from campus. Field site and all travel associated with field projects will be undertaken consistently with all KU and KGS policies and procedures.
22. All field crew members will read and sign the safety plan prior to departing.

II. FIRE PREVENTION AND PROTECTION PROGRAM

The overall objective of the KGS field fire prevention and protection program is to maintain a consistent awareness of fire potential in our various areas of responsibility. It is imperative to be ever vigilant in identifying ignition sources and potential spark-advancing fuels. These concerns span not only flammable materials brought on-site by the KGS, but also any combustible or explosive materials already on the site or naturally present within the study area.

Seismic operations involve the controlled release of large quantities of energy. Some sources of that energy require explosions that are an ignition source, while others generate sufficient heat in the presence of flammable liquids to potentially exceed the ignition point of many combustible materials. Therefore, when site conditions are conducive to sustaining combustion, extreme caution is required when operating seismic sources.

All gasoline engines have spark arrest exhausts to reduce the threat of igniting any combustible or flammable materials.

Smoking is only allowed in designated areas and all cigarette butts and ashes are disposed of in sand-filled cans provided in smoking areas. Under no circumstances are lit cigarettes discarded on the ground in work areas.

Several areas of specific concern and operational awareness are:

- a) handling and storage of flammable materials
No flammable solids will be transported or used during normal seismic surveying. Flammable liquids will be limited to petroleum products such as diesel, gasoline, lubricating oils, etc.
- b) containment of flammable liquids
Flammable liquids will be transported to the site in steel, U.S. Government approved nurse tanks, mounted in the bed of a truck, and labeled appropriately (and a single 5-gal. can to allow fill-up remote from nurse tanks). These flammable liquids include diesel and gasoline used for fuel in the seismic vibrator and support UTVs. Quantities transported in nurse tanks will not exceed 100 gallons of either type. Petroleum operated engines will have fuel supplied via manufacture provided and certified fuel tanks. Transfer pumps will be installed and maintained in accordance with manufacturer specifications.
- c) fire protection at storage locations
The nature of seismic work prohibits effective use of fixed storage locations. All mobile facilities (trailers) will have fire extinguishers at or near doors. Vehicles will have fire extinguishers located in accord with KDOT regulations.
- d) how fires shall be handled on project
All personnel will be educated on the fire triangle and matching extinguisher types with fires. All on-site KGS staff will have been instructed, prior to arrival on site, to the appropriate procedures for fire containment and extinguishing, making the removal of any one side of the fire triangle the principal objective.
- e) fire watch or hot work permits
No hot work will be undertaken on-site. Fire watch will be a supplemental task of every member of the seismic crew.

III. SAFETY PERSONNEL

Safety Personnel and Emergency Contacts

1. Rick Miller (KGS)—Site Safety Officer
2. Brett Wedel (KGS) --Operations
3. _____ (Burns & McDonnell)—Sponsor's Technical Representative
4. _____ (Burns & McDonnell)—Sponsor's Site Representative



BROWNFIELD SAFE WORK PERMIT or AUDIT FORM

Compliance	Likelihood				
	1	2	3	4	5
A	A1	A2	A3	A4	A5
B	B1	B2	B3	B4	B5
C	C1	C2	C3	C4	C5
D	D1	D2	D3	D4	D5

Completed by a Supervisor and Employee(s) doing the task

PERMIT or AUDIT DATE: _____

COMPANY NAME: Burns & McDonnell

TASK DESCRIPTION: Geophysical Survey | _____

Is task listed in Hazard Assessment Matrix? This task's Risk Rating? _____ Is there a Task Risk Assessment for this task? YES NO

YES NO NO | Does a Task Risk Assessment need to be developed? YES NO

FACILITY AND TASK LOCATION: Former IMC Salt Facility - Hutchinson, KS

CONTRACTOR TASK REQUIREMENTS

Lockout Sfa Utility Location One Call utility Location Ground Disturbance Trench Entry (+1.2m)

Electrical Work Hot Work Mobile Equipment Dyke/Gypstack Repair Work Closet to Water

Pesticide/Herbicide Application Structural Maintenance Chemical Spill Clean-up Confined Space Entry Working Above 1.2m

LOCKOUT REQUIRED: NO YES (One Man - One Lock) **EQUIPMENT - LOCKS INSTALLED**

1. _____ | 2. _____ | 3. _____ | _____

TASK HAZARDS:

Slips, Trips, or Falls Caught In, On or Between Struck By Sharp Objects/Edges Drowning

Awkward Body Position Restricted Work Area Electricity/High Voltage Rotating Equipment Equipment Roll-over

Chemicals Rubber Lined Equipment Working Alone Nature's Hazards High Noise Levels

Weather Conditions Fire Moving Heavy Objects Underground Utilities Above Ground Utilities

RISK REVIEW REQUIREMENTS: (Attach Risk Review to Safe Work Permit)

MSDS Lockout Electrical Work Hot Work Dyke/Gypstack Repair

Ground Disturbance Trench Entry Working close to water Machine Guarding Working Above 4' (1.2m)

Working Surfaces Confined Space _____ _____ _____

SAFETY REQUIREMENTS:

Rubber Gloves Face Shield/Goggles Dust Mask Contact Supervisor Respirator

Life Jacket Gloves (specially) Ground Fault Protection Fall Arrest Equipment Air Testing Equipment

Two Workers Ear Plugs Ladder Chainsaw Chaps Extraction Equipment

Rain Suit Radios/Cell phones Fire Extinguisher Barricades (Tape/Physical)

LOCKOUT SAFETY CHECK: NA *Completed By Authorized Mosaic Employee*

Equipment Locked and Tagged Electrical Bump Test Completed Equipment De-pressurized and Drained

Signatures: Indicate risk mitigation and work authorization

Consultant Supervisor: _____ **Contra or Supervisor:** _____

Employee: 1. _____ | _____ | _____

** Requires a written Task Risk Assessment and approval from the Consultant Site Supervisor prior to starting the task.*

Comments:

August 15, 2014

General Maps

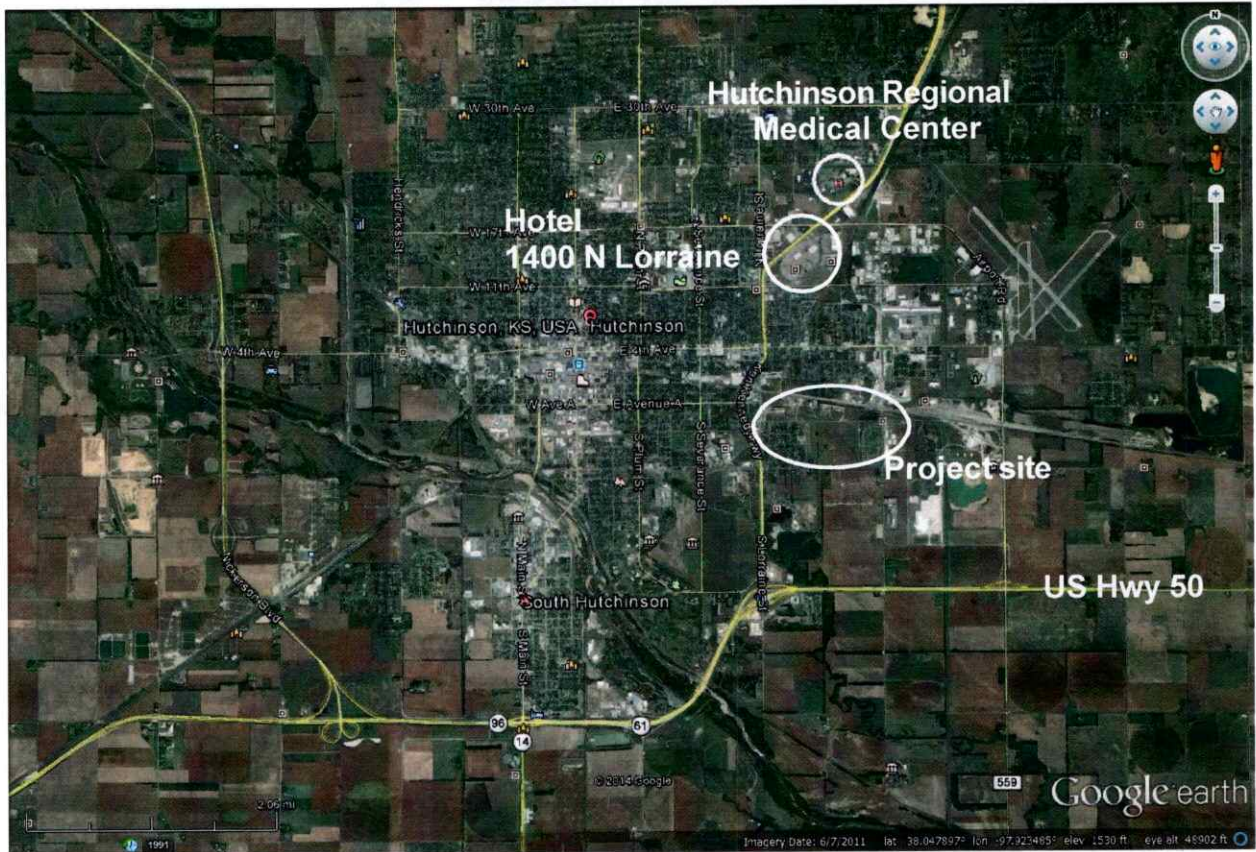

City of Hutchinson and location of pertinent sites.

See next page for more detailed map and route to Hutchinson Regional Medical Center.

Emergency Route to Hospital

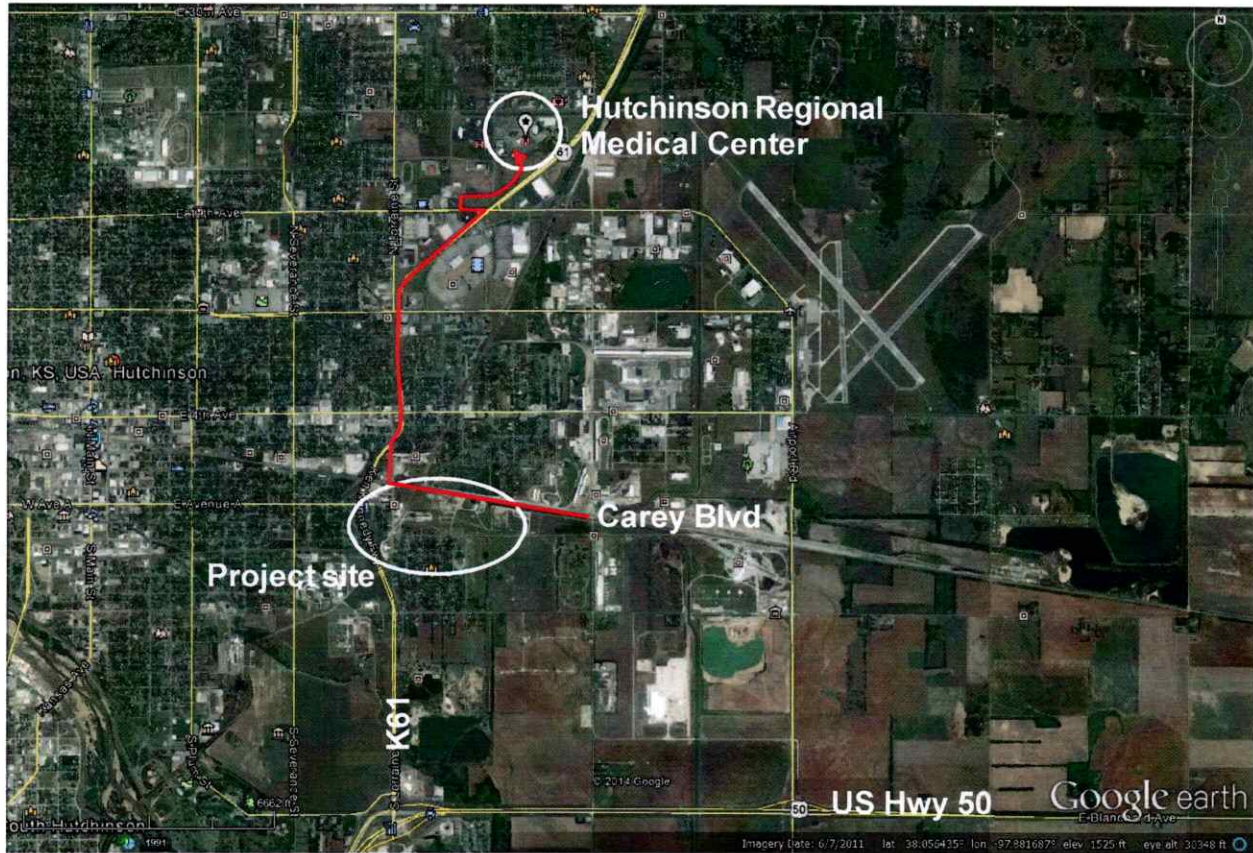

Overall location of hospital in relation to project site, plus route from site to Hutchinson Regional Medical Center Emergency.

1. From project site, go west on Carey Boulevard to S Lorraine St.
2. Turn north on S Lorraine St, to K61/Ken Kennedy Fwy, about 0.5 miles.
3. Slight turn to right onto K61/Ken Kennedy Fwy headed north, then go ~1.4 miles.
4. Sharp turn left at E 17th Avenue (heading west), go 0.2 miles.
5. Turn right onto N Waldron Street, it will curve to your right. When N Waldron turns north (left), stay to the right (on Google Earth this is called Waldron Street).
6. Follow this road until you see Emergency on the right, two big red plus signs on the south side of the hospital building.

For a more detailed map of Steps 4-6, see next page.



[Steps 4-6 repeated here for your convenience.]

4. Sharp turn left at E 17th Avenue (heading west), go 0.2 miles.

5. Turn right onto N Waldron Street, it will curve to your right. When N Waldron turns north (left), stay to the right (on Google Earth this is called Waldron Street).

6. Follow this road until you see Emergency on the right, two big red plus signs—one facing south, one facing east—on the the hospital building. Emergency room is approximately at the “C” balloon on above map.

[ignore “B” balloon]

Procedures

Accidents/Injury: If any serious injury does occur, the appropriate authorities shall be notified immediately. All accidents will also be reported.

Several members of the KGS crew have certification in CPR/First Aid. This certification was received through participation in the “First Aid Basics” and “Adult CPR” programs presented by the Red Cross of Lawrence, Kansas. These classes are approved by the U.S. Department of Labor, Mine Safety, and Health Administration and meet or exceed OSHA requirements. OSHA certifications are provided by Genesis Environmental (formerly EPIC Training) and meet or exceed 29 CFR 1910.120.

The following persons are certified as indicated (strikethrough denotes no current certification):

Certifications

First Aid	CPR	40hr OSHA	10hr OSHA	<u>Rick Miller</u>
First Aid	CPR	40hr OSHA	10hr OSHA	<u>Brett Wedel</u>
First Aid	CPR	40hr OSHA		<u>Shelby Peterie</u>
First Aid	CPR			<u>Connor Umbrell</u>
First Aid	CPR			<u>Cole Bunker</u>
First Aid	CPR			<u>Robbie Kieffer</u>
First Aid	CPR		8hr adm	<u>Kathy Sheldon</u>

Fire/Explosion: Upon notification of a fire or accidental explosion on site, the fire department or appropriate first responders shall be notified, and all personnel shall leave the area. Since only Class "C" ammunition will be used as part of the program, local fire, police, and other governing authorities will not be contacted prior to the use of such devices on-site. On-site

Burns & McDonnell demolitions personnel will manage and respond to any situation. If Class "A" explosives were used, prior consultation and contact would be made with the appropriate emergency response groups.

At least one KGS (owned or rented) vehicle will be on-site during the performance of all work. This vehicle will be used for medical evacuation of project personnel, if necessary.

Permits: All necessary and appropriate permits, fees, and licenses will be obtained by **Burns & McDonnell**, with copies available on-site for inspection by local authorities.

**Kansas Geological Survey
Incident Report Form**

Date of incident: _____

Location of incident: _____

Was anyone injured? Yes No If yes, name(s) of injured person(s):

Uninjured person(s) involved in incident: _____

Other witnesses (not involved): _____

Equipment involved in incident: _____

Narrative of what happened (continue on reverse of this page and draw a diagram if it helps explain what happened):

Site Safety Officer

Certificate of Completion

Marcus Tamburro
has completed the requirements for:
Adult First Aid/CPR/AED
conducted by
American Red Cross
Date Completed: 2022-12-08
Valid Period: 2 Years
Certificate ID: 0132NE0

Scan or visit: redcross.org/confirm



Certificate of Completion

Cole Bunker
has completed the requirements for:
Adult First Aid/CPR/AED
conducted by
American Red Cross
Date Completed: 2022-12-08
Valid Period: 2 Years
Certificate ID: 0132NFE

Scan or visit: redcross.org/confirm



Certificate of Completion

Richard Miller
has completed the requirements for:
Adult First Aid/CPR/AED
conducted by
American Red Cross
Date Completed: 2022-12-08
Valid Period: 2 Years
Certificate ID: 0132NFO

Scan or visit: redcross.org/confirm



Certificate of Completion

Brett Wedel
has completed the requirements for:
Adult First Aid/CPR/AED
conducted by
American Red Cross
Date Completed: 2022-12-08
Valid Period: 2 Years
Certificate ID: 0132NE6



Certificate of Completion

Shelby Peterie
has completed the requirements for:
Adult First Aid/CPR/AED
conducted by
American Red Cross
Date Completed: 2022-12-08
Valid Period: 2 Years
Certificate ID: 0132NEA

Scan or visit: redcross.org/confirm



Certificate of Completion

Kathleen Sheldon
has completed the requirements for:
Adult First Aid/CPR/AED
conducted by
American Red Cross
Date Completed: 2022-12-08
Valid Period: 2 Years
Certificate ID: 0132NFI

Scan or visit: redcross.org/confirm

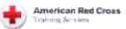

Certificate of Completion

Connor Umbrell
has completed the requirements for:
Adult First Aid/CPR/AED
conducted by
American Red Cross
Date Completed: 2022-12-08
Valid Period: 2 Years
Certificate ID: 0132NFR

Scan or visit: redcross.org/confirm



Certificate of Training
GES Training Services
Hereby Certifies
RICK MILLER
Has Completed
OSHA's 29 CFR 1910.120
HAZWOPER Refresher Training
24 May 2026
Expiration Date
Robert L. McChan
Director of Training

Certificate of Training
GES Training Services
Hereby Certifies
SHELBY PETERIE
Has Completed
OSHA's 29 CFR 1910.120
HAZWOPER Refresher Training
24 May 2026
Expiration Date
Robert L. McChan
Director of Training

Certificate of Training
GES Training Services
Hereby Certifies
BRETT WEDEL
Has Completed
OSHA's 29 CFR 1910.120
HAZWOPER Refresher Training
24 May 2026
Expiration Date
Robert L. McChan
Director of Training

Certificate of Training
GES Training Services
Hereby Certifies
KATHY SHELDON
Has Completed
OSHA's 29 CFR 1910.120
HAZWOPER Refresher Training
24 May 2026
Expiration Date
Robert L. McChan
Director of Training

**Off Road
Vehicle Certification**
Anthony Hoch

Hereby certifies the above
has completed NMP's UTV/ATV training course
on the proper and safe operation of UTVs/ATVs

EXP DATE:
12/31/24



Instructor Signature:
Brett Wedel

**Off Road
Vehicle Certification**
Brett Wedel

Hereby certifies the above
has completed NMP's UTV/ATV training course
on the proper and safe operation of UTVs/ATVs

EXP DATE:
12/31/24



Instructor Signature:
Brett Wedel

**Off Road
Vehicle Certification**
Robbie Kieffer

Hereby certifies the above
has completed NMP's UTV/ATV training course
on the proper and safe operation of UTVs/ATVs

EXP DATE:
12/31/24



Instructor Signature:
Brett Wedel

**Off Road
Vehicle Certification**
Shelby Peterie

Hereby certifies the above
has completed NMP's UTV/ATV training course
on the proper and safe operation of UTVs/ATVs

EXP DATE:
12/31/24



Instructor Signature:
Brett Wedel

**Off Road
Vehicle Certification**
Rick Miller

Hereby certifies the above
has completed NMP's UTV/ATV training course
on the proper and safe operation of UTVs/ATVs

EXP DATE:
12/31/24



Instructor Signature:
Brett Wedel

**Off Road
Vehicle Certification**
Carl Gonzales

Hereby certifies the above
has completed NMP's UTV/ATV training course
on the proper and safe operation of UTVs/ATVs

EXP DATE:
12/31/24



Instructor Signature:
Brett Wedel

**Off Road
Vehicle Certification
Marcus Tamburro**

Hereby certifies the above
has completed NMP's UTV/ATV training course
on the proper and safe operation of UTVs/ATVs

EXP DATE:
12/31/24



Instructor Signature:
Bert A. Will

**Off Road
Vehicle Certification
Cole Bunker**

Hereby certifies the above
has completed NMP's UTV/ATV training course
on the proper and safe operation of UTVs/ATVs

EXP DATE:
12/31/24



Instructor Signature:
Bert A. Will

**Off Road
Vehicle Certification
Connor Umbrell**

Hereby certifies the above
has completed NMP's UTV/ATV training course
on the proper and safe operation of UTVs/ATVs

EXP DATE:
12/31/24



Instructor Signature:
Bert A. Will

Certificate of Training

GES Training Services

Hereby Certifies

SHELBY PETERIE

Has Completed

OSHA's 29 CFR 1910.120

HAZWOPER Refresher Training

Robert J. McEwan

Director of Training

13 May 2025
Expiration Date

This is to Certifi

That

Shelby Peterie

Has Successfully Completed

**HAZWOPER
40 hrs
Training**

Certificate: #10092009-1

Training Dates: 10/05 - 10/09/2009

Location of Training: National Starch & NKC Library Training Center
North Kansas City, Missouri

Level of Training: HAZWOPER Initial Site Worker & Emergency Response

Provider of Training: DA Shafer, EHS Management Services LLC, KC Mo.

Directives: OSHA 29CFR 1910.120 Appendices E-Q
OSHA 29CFR 1926.65
OSHA 29CFR 1910.38
OSHA 29 CFR 1910.134
EPA/RCRA 40CFR 260-265
PHMSA 49CFR 172-173 Awareness
DHS/DOT Security Awareness
NIMS Incident Management
WISER 2009
ERG 2008/2009 Resource Disk

Instructor:

Donald A. Shafer
CET, CIPS, CSEM, CEAA, CCHSI

Certificate of Training

Genesis Environmental Solutions

Hereby Certifies that

Brett Wedel

Has successfully completed

**OSHA's Hazardous Waste Operations and Emergency
Response**

Work practices standard 29 CFR 1910.120

40 Hour Hazardous Waste Operation Training

In witness whereof this certificate is awarded

On the 8th day of June, 2007

Robert L. McChan II

Director of Training

Michael S. Thomas

Director of Operations

Robert L. McChan II

Instructor

Certificate of Training
GES Training Services
Hereby Certifies

BRETT WEDEL

Has Completed

OSHA's 29 CFR 1910.120

HAZWOPER Refresher Training

13 May 2025

Expiration Date

Robert L. McChan

Director of Training



Certificate Of Training

Environmental Protection
Instruction/Consulting

Hereby Certifies that



Richard D. Miller
has successful,

OSHA's HAZARDOUS WASTE OPERATIONS

work practices standard 1910.120

OSHA Compliance Training 40 hour
in witness whereof this certificate is awarded

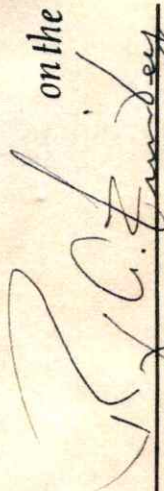
on the **17th** day of **Jan., 1992**

Director of Training

Educational Administrator

Instructor



Certificate of Completion

Presented to:
RICK MILLER

On 3/11/2011, RICK MILLER successfully completed the 10-Hour OSHA
Outreach Training Course for the Construction Industry.

Taylor Alan Sikor

OSHA Authorized Trainer

USF UNIVERSITY OF
SOUTH FLORIDA

OSHA TRAINING
INSTITUTE
EDUCATION CENTER

**American
Safety Council**
.com

Certificate of Completion

Presented to:
BRETT WEDEL

On 3/11/2011, BRETT WEDEL successfully completed the 10-Hour OSHA
Outreach Training Course for the Construction Industry.

Taylor Alan Siken

OSHA Authorized Trainer

USF UNIVERSITY OF
SOUTH FLORIDA

OSHA TRAINING
INSTITUTE
EDUCATION CENTER

**American
Safety Council**
.com

Certificate of Completion

This certifies that

Cole D. Bunker

has successfully completed all required training and coursework in
Hazardous Waste Operations & Emergency Response (HAZWOPER)

in accordance with 29 CFR 1910.120
40 Contact Hours

Instructor

Dean



Barton Community College
100 Continental Drive
Grandview Plaza, KS 66441

November 3-7, 2025
Training Date
November 7, 2026
Expiration Date

Certificate of Completion

This certifies that

Connor A. Umbrell

has successfully completed all required training and coursework in

Hazardous Waste Operations & Emergency Response (HAZWOPER)

in accordance with 29 CFR 1910.120

40 Contact Hours

James Henderson
Instructor

James Henderson
Dean



Barton Community College
100 Continental Drive
Grandview Plaza, KS 66441

25-6694

November 3-7, 2025
Training Date
November 7, 2026
Expiration Date

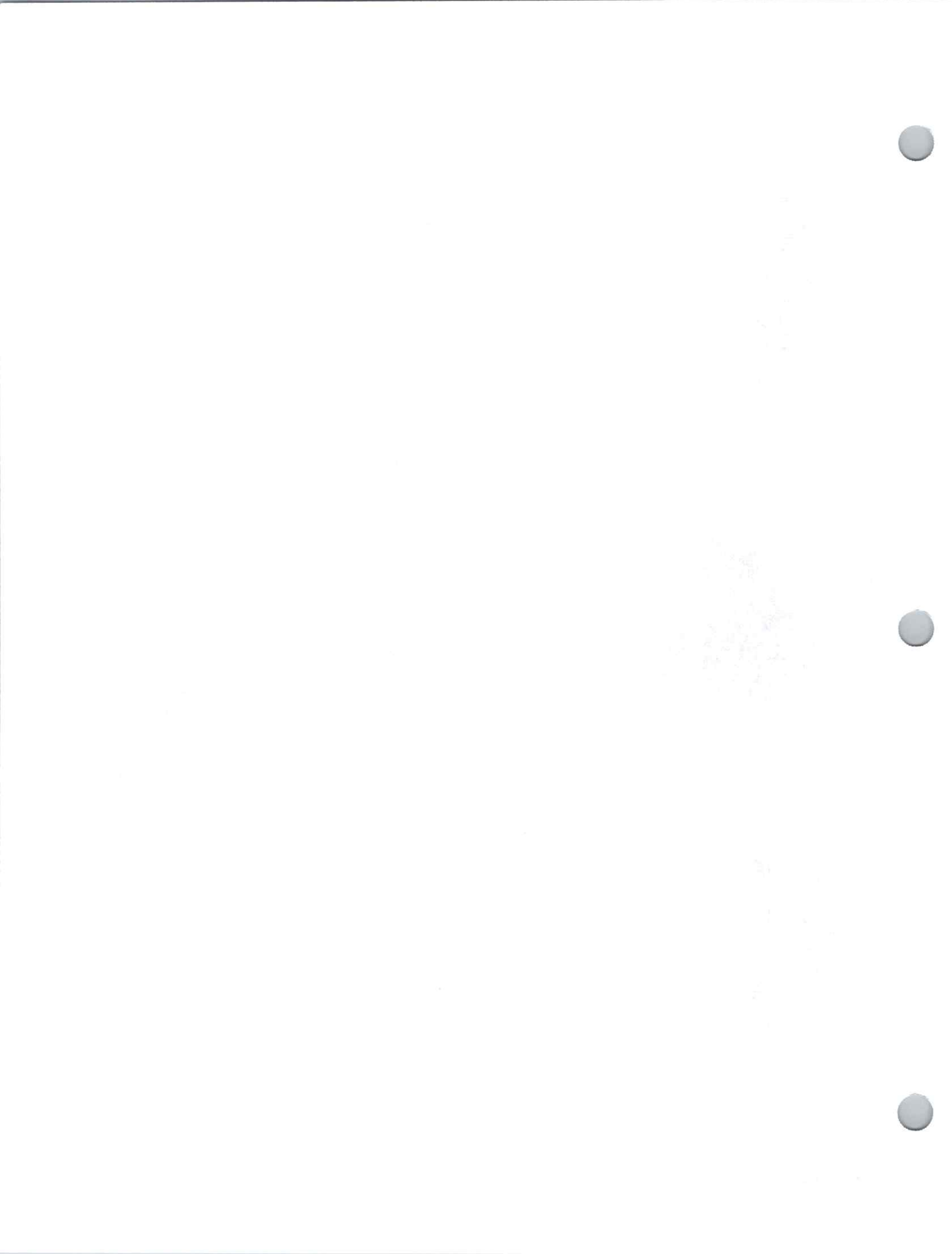

V. ALCOHOL AND DRUG POLICY

The University of Kansas (of which the KGS is a part) is a drug and alcohol-free workplace with stringent controls and penalties associated with the use and distribution of controlled substances and alcohol in the workplace regardless of whether it is at a remote field location or on campus. The University of Kansas and Kansas Geological Survey consider alcohol and drug use (non-doctor prescribed) while “on-duty” a health and safety risk. The following section details the University and Survey policy as it relates to drug and alcohol abuse and misuse, enforcement of policies, and penalties for violating those policies.

Policy on Prevention of Illegal Drug and Alcohol Use on Campus and in the Workplace

The University of Kansas prohibits the unlawful possession, use, manufacture, or distribution of alcohol or drugs by students and employees on its property or as part of its activities. The University is committed to a program to prevent the illegal use of drugs and alcohol by students and employees. Any student or employee found to be using, possessing, manufacturing, or distributing controlled substances or alcohol in violation of the law on University property or at University events shall be subject to disciplinary action in accordance with applicable policies of the State of Kansas, the Board of Regents, and the University of Kansas. For employees, the University will take appropriate personnel action for such infractions, up to and including termination. Students who violate this policy will be subject to sanctions, which include suspension and expulsion from the University.

As a condition of employment, all employees of the University of Kansas shall abide by the terms of this policy statement and will notify the University of any criminal drug statute conviction for a violation occurring in the workplace no later than five days after such conviction. The University will, in turn, notify as appropriate, the applicable federal agency of the conviction within ten days of receipt of notification of the conviction. The University will initiate personnel action, up to and including termination, within thirty days of receiving notice of such conviction. Employees may also be required to satisfactorily participate, at their own expense, in a drug abuse assistance or rehabilitation program before being allowed to return to work. For purposes of this policy, “conviction” means a finding of guilt (including a plea of nolo contendere) or imposition of sentence, or both, by any judicial body charged with the responsibility to determine violations of the federal or state criminal drug statutes.

Kansas Law

Students and employees are reminded that illegal possession or use of drugs or alcohol may also subject individuals to criminal prosecution. The University will refer violations or proscribed conduct to appropriate authorities for prosecution. Kansas law provides that any person who violates the criminal statutes on controlled substances by possessing, offering for sale, distributing, or manufacturing opiates and narcotics, such as cocaine and heroin, shall be guilty of a drug severity Level 3 felony. For a conviction of such a felony, the court may sentence a person to a term of imprisonment in accordance with the Kansas Sentencing Guidelines Act and a fine of up to \$300,000. Unlawful possession of a depressant, stimulant or hallucinogenic drug is punishable as a Class A nonperson misdemeanor, with a penalty of imprisonment and a fine of \$2,500. Depressants include barbiturates, Valium, and barbital. Hallucinogens include LSD, marijuana, and psilocybin. State law classifies amphetamines and methamphetamines as stimulants. Kansas statutes also provide criminal penalties for conviction of certain alcohol-related offenses. These penalties include imprisonment of up to six months and fines of up to \$1,000.

Federal Law

The Federal Controlled Substances Act provides penalties of up to life imprisonment and fines up to \$4,000 for intentional unlawful distribution or possession with intent to distribute controlled substances. For unlawful possession of a controlled substance, a person is subject to up to twenty years of imprisonment and fines up to \$5,000. Any person who unlawfully distributes a controlled substance to a person under twenty-one years of age or who distributes a controlled substance on or within 1,000 feet of the University may be punished by up to twice the term of imprisonment and fine otherwise authorized by law.

Health Risks

Accidents and injuries are more likely to occur if alcohol and drugs are used on university property or as part of university activities. Every year in the United States, over 200,000 people are treated in hospitals for drug-related accidents and mental and physical illness; another 25,000 die every year from drug-related accidents or health problems. Drug users can lose resistance to disease and destroy their health. Drug tolerance and psychological dependence can develop after sustained use of drugs. More specifically, physical dependency, heart problems, infections, malnutrition, and death may result from continued high doses of amphetamines. Chronic use of narcotics can cause lung damage, convulsions, respiratory paralysis and death. Depressants such as tranquilizers and alcohol can produce slowed reactions, slowed heart rate, damage to liver and heart, respiratory arrest, convulsions, and accidental overdoses, because the abuser is unaware of how much the drug or alcohol has been taken. Use of hallucinogens may cause psychosis, convulsions, coma, and psychological dependency.

Alcoholism is the number one drug problem in the United States. Alcoholism takes a toll on personal lives by affecting finances, health, social relationships, and families. It can have significant legal consequences. Abuse of alcohol or use of drugs may cause an individual driving a motor vehicle to injure others and may subject the abuser to criminal prosecution. Drunk drivers are responsible for more than half of all traffic fatalities.

Counseling & Treatment Resources

At the University of Kansas, alcohol and drug counseling and treatment are available to students at the University Counseling and Psychological Services, Watkins Health Center, and the Psychological Clinic. The Student Assistance Center and the University Information Center are excellent sources for information about university and community resources for counseling and treatment. The Health Education Department of Watkins Health Center can provide further information about health problems and treatment related to alcohol and drug problems.

University employees may contact the Counseling and Psychological Services and the Psychological Clinic for counseling and treatment. Faculty and staff members may also contact the State LIFeline, a 24-hour toll-free assistance line (1-800-284-7575) for a referral. If referred through the LIFeline program, the first counseling session is paid by the State. Please refer to page 63 for additional resources.

Definitions

The term "controlled substance" as used in this policy means those substances included in Schedules I through V as defined by Section 812 of Title 21 of the United States Code and as further defined by the Code of Federal Regulations, 21 C.F.R. 1300.11 through 1300.15. The term does not include the use of a controlled substance pursuant to a valid prescription or other uses authorized by law.

The term "alcohol" as used in this policy means any product of distillation or a fermented liquid which is intended for human consumption, and which is more than 3.2% alcohol by weight as defined in Chapter 41 of the Kansas statutes.

Policy on Substance Abuse

The University recognizes that problems related to the abuse of substances such as alcohol and drugs may be resolved through cooperation between the employer and the affected employee. The policy set forth here for handling substance-abuse problems is intended to enhance cooperation and to protect both the individual and the University.

The University has a right to expect that employees will perform their jobs appropriately and to insist that job-performance standards be met. The University may properly intervene only when impairment affects job performance.

- These problems are defined as those in which an employee's use of alcohol or drugs has become part of a pattern of deteriorating job performance.
- This policy does not supersede any regulations or standard administrative practices applicable to job performance requirements.
- It is the employee's right and responsibility to seek professional assistance for a substance-abuse problem.
- All employees, especially department chairpersons and supervisors, should work to engender an enlightened attitude toward and a realistic recognition of the nature of substance abuse and to encourage employees to take advantage of available treatments whenever needed.
- Responsibility for implementing this policy rests with all department chairpersons and supervisory personnel. Procedures must be followed to ensure that no employee with a substance-abuse problem will have his or her job security or promotional opportunities jeopardized by a request for diagnosis and treatment.
- A chairperson or supervisor may wish to consult with a professional in the treatment of substance abuse *WITHOUT IDENTIFYING THE CONCERNED EMPLOYEE* before attempting intervention with the employee.
- Before attempting intervention, a supervisor of classified staff should discuss with his or her own supervisor and the Department of Human Resources the rules and requirements protecting the rights of the person believed to be suffering from alcoholism or drug abuse.
- Departmental chairpersons and supervisors should not attempt diagnosis. When an employee's job performance is deteriorating and there is reason to suspect that the source may be the use of alcohol or drugs, the chairperson or supervisor will meet informally with the employee, make an appropriate referral to a professional agency and encourage him or her to seek help for the problem. At this meeting, a date will be set by which improvement in job performance will be assessed.
- The employee is responsible for complying with the referral for diagnosis and for cooperating in any prescribed treatment. He or she should be assured that the referral agency will treat all discussions with strict confidentiality. (Most agencies will, with the consent of their client, report to a supervisor that the client has followed up on a referral.)
- Between the time of the meeting and the date set for assessing improvement in job performance, the chairperson or supervisor will continue to monitor the performance but will in all other respects leave the initiative for further discussions with the employee.

- If, by the date set at the first meeting, the employee's job performance has improved to an acceptable level, no further official action is required.
- The University expects that employees with a possible problem of substance abuse, even in its early stages, will be encouraged to seek diagnosis and treatment. The employee should be assured that seeking help will not interfere with job status, promotional opportunities or other privileges.
- If the job performance remains below accepted standards and the employee has refused to accept diagnosis and treatment, or has failed to respond to treatment, the chairperson or supervisor should suggest that he or she use one of the options available to any employee with an illness that interferes with job performance:
 - a. Being placed on sick leave. This option is for those with accrued leave. It would allow the employee to enter an inpatient treatment center and adopt a treatment program. Under this option, a written plan should be developed between the staff member and the University and properly executed by the chairperson or supervisor in consultation with Human Resources. The plan will spell out specifically the terms of the employee's return to his or her duties at the end of treatment (e.g., how the University is to be informed of the progress made in treatment and the appropriateness of a return to duty and how job performance is to be assessed).
 - b. Being granted a leave of absence without pay for up to twelve months. This option is for classified employees, with approval of the Department of Human Resources.
 - c. Taking early retirement. This option is for those otherwise eligible. It is, of course, a drastic solution for both the individual and the University.
 - d. Resigning. If a classified employee can make no progress, recommendations to demote or dismiss are to be submitted to the Department of Human Resources for review and action.

Information revealed by the employee while receiving professional services will remain confidential and separate from university employee records. All record-keeping and access procedures will meet the federal regulations governing the confidentiality of patient records and the state law protecting treatment records.

VI. TASK SPECIFIC HAZARDS

The purpose of the geophysical investigation is to acquire seismic data that can be used to extract key physical properties of the near surface.

Downhole Auger Gun

One of the geophysical tests proposed to be employed requires the use of an auger gun (shotgun type device) to introduce energy into the ground (Healey et al., 1991). This device consists of a small skid-steer loader with an attached auger/screw. The operation consists of (1) screwing the hollow stem auger approximately 3 ft into the ground, (2) retrieving the center bit, (3) loading the shell in the firing tube and lowering the tube until it latches in place, (4) firing the gun by impacting the top of the firing tube with a small hammer, and (5) unscrewing the auger from the ground. The auger gun uses a *blank* 8-gauge, or 12-gauge shotgun shells fired below the ground surface in a downward direction. The device is built to minimize any danger to persons handling and moving the device, as well as avoid leaving any residual materials in the ground. The shotgun shells will be secured in a specially designed steel, lockable, explosives box attached to a vehicle at all times. The operation/safety rules and regulations for the auger gun are presented as an appendix to this plan.

30.06 Downhole Projectile Source

Experiments will be carried out with a downhole projectile source. This source is a specially modified 30.06 rifle designed to be loaded and fired while secured to the ground in a downward direction. The firing tube is lowered about one foot into a 1" hole. A standard 30.06 rifle shell is loaded in the above-ground breech and then detonated so that air coupled wave (blast), gas, projectile, and shrapnel are contained within the 1" hole. The procedure calls for 1) drilling a 1" x 1' hole, 2) placing the firing tube in the hole (covering the end of the tube with a finger cot), 3) loading a 30.06 round into the above-ground breech, 4) locking the bolt in place, 5) assuming the firing position, 6) detonation, and 7) removal from the hole. The device has successfully and safely fired over 30,000 rounds since 1985. All rounds are stored in a secure steel box.



Sledgehammer

The sledgehammer is a well understood and available source of acoustic energy. The sledgehammer will be used with a hard-wire time break and will be operated by physically capable KGS staff members. An area twice the length of the hammer handle will be cleared prior to use. The hammer will be 1) raised above the operator's head using a two-hand grip, 2) accelerated with full arm extension toward the ground, 3) contact striker plate with hammer, and 4) lifted into split two-hand carry grip. Activities such as changing broken handles and attaching new hammer switches should only be done by experienced KGS staff.



A minimum clear area directly in front of the operator of at least 25 ft must be maintained in case the operator loses grip on hammer or hammer head breaks free from the handle. Gloves, safety glasses, steel-toed boots, and hearing protection are required for operating this source.

Accelerated Weight Drop

The accelerated weight drop is a high energy, hydraulically operated source. All moving parts are shielded and designed to minimize risk of injury to operators and bystanders. By its very nature the weight drop represents a hearing danger. The source is powered by a standard commercial loader. A single operator runs the device from inside a protective cab. Operation simply requires 1) the base plate to be placed on the ground and loader/weight drop weight applied for hold down, 2) idle at medium rpm and initiate the hydraulic valve, 3) weight is raised against resistive force (bungies), 4) dropped once maximum pre-set height is reached, and 5) source is hydraulically lifted and carried to next shot point by tracked loader. The source is sufficiently shielded that only in a very unusual situation will pieces of the source come free from the source and represent a threat to safety. By maintaining a minimum 30 ft for hearing safety, the danger of fragments is all but eliminated.



Bolt LSS-6 Land Air Gun

The Bolt Land Air Gun has been in routine use in oil exploration for more than 20 years. The device consists of a 3-cylinder diesel engine, a four-stage air compressor, and an enclosed water filled chamber (housing the "gun"). The safe operation of the gun is well documented in the operator's manual. The entire device is transported as the bed of an



F-350 4-wheel drive truck. The 3-cylinder diesel engine powers not only the air compressor but also a hydraulic system designed to raise and lower the gun chamber to the ground. The gun chamber is hydraulically lowered to the ground with the weight of the truck used to hold the device to the ground. The gun is electrically detonated from the cab of the truck with no moving parts exposed during detonation. The engine and air compressor are enclosed in a protective shroud. The gun generates a thump to the ground surface approximately equivalent to 1/8 of a pound of high explosive buried 3 to 4 ft beneath the ground surface.

IVI Minivib

The MiniVib is a hydraulically powered vibrator designed to shake the ground in a very controlled fashion over about a 4 to 8 second time duration. The device is hydraulically powered with no moving parts that possess an entanglement potential. Energy is delivered to the ground by this device through a hydraulically powered pad approximately 3 ft in diameter mounted on the belly of the vehicle. The pad is lowered from beneath the vehicle using the vehicle's weight as hold-down pressure. The pad is vibrated by a hydraulic servo delivering frequency-varying energy to the plate over a preset time duration. No moving parts are exposed with the maximum movement of the pad relative to the vehicle less than 2 in.



50-cal. Downhole

The downhole .50-caliber seismic source consists of a .50-cal. rifle bolted to a 0.6 cm thick steel plate. The rifle itself is a standard .50-cal. breech and bolt, built by Texas Gun and Machine Company, attached to a standard .50-cal. machine gun barrel. Machined grooves in the barrel are used in conjunction with a pressure clamp to attach the rifle to a 30 cm by 90 cm steel plate. The rifle barrel is lowered into a 60 cm to 80 cm deep borehole 4 cm in diameter until

the plate is flush with the ground surface. This steel plate acts as a ground seal and a platform to stand on while firing the gun. The weight of the shooter on the plate and the snug fit of the barrel to the borehole walls help seal the gun to the ground. The rifle can be equipped with a source sensor or closure switch to generate a time break. Firing can be done either electrically by solenoid or manually by pulling the trigger. The downhole .50-cal. weighs about 30 kg and is easily two-person portable. Safety rules for the use of the .50-cal. seismic gun are presented as an appendix to this plan.

Paintball Impulsive Seismic Source

A standard of-the-shelf paintball marker has been modified to impart a series of high frequency air pulses into the ground through a specially modified barrel. The pulse sequence is electronically controlled to optimize its use as a coded seismic source. The barrel was designed and built at the Kansas Geological Survey and it has no single opening at the end of the barrel. The barrel is plugged at the end with around 50 small holes drilled in the sides of the barrel to release the gas pulse below ground surface.

The seismic paintball source is pushed by hand to a predetermined and measured depth (~6 inches). The discharge valve is electronic and controlled by a computer circuit. Operation of the commercially available portion of this source is completely consistent with manufacturer's instructions as they relate to the use, storage, and transportation of the compressed air cartridges. This seismic source cannot launch a projectile of any kind. This source is treated like all other sources—with maximum concern for safety.



Downhole Firing Rod

Detonation of black powder blank shells (shotgun shells) has proven to be a reliable and energetic seismic source. Originally developed by the Canadian Geological Survey and Bison Instruments, the Buffalo Gun was a cheap and efficient delivery system for subterranean detonation of blank load shotgun shells. The current configuration of the downhole detonation system is 'downhole firing rod,' a term coined by Betsy Seisgun.

The system we use includes a 4 ft long, thick-walled steel tube with a stainless steel chamber that screws onto the downhole end. Inside the thick-walled tubing is a stainless steel rod that acts as the firing rod. The firing rod is locked in place away from the shell chamber using a set screw device. The shell is placed in the chamber and screwed onto the end of the rod.



The rod is lowered into a pre-drilled 2" hole and seated with water. A blast mat is placed at the ground surface and the firing rod is freed from its locked position. The top handle of the firing rod is then impacted with a small rubber mallet and the firing rod detonates the percussion-style shotgun shell.

Shear Wave Block

The shear wave block, much like the sledgehammer, is a good source of acoustic energy. The shear wave block also uses a hard-wire time break and a physically capable KGS employee. The 360 area the twice the length of the hammer handle will be cleared prior to use. The sledgehammer will be 1) raised above the operator's head using a two-hand grip, 2) accelerated with the full arm extension downward in a parallel to the ground contact point with the shear block, and 4) lifted into a split two-hand carry grip. Changing broken handles, attaching new hammer switches, and tightening the nuts on the shear block should only be done by experienced KGS staff. A minimum clear area directly in front of the operator of at least 25 ft must be maintained in case the operator loses grip on hammer or hammer breaks free off the handle. Gloves, safety glass, steel-toed boots, and hearing protection are required for operating this source.

General

Field operations will consist of geophysical investigations to determine the effectiveness of shallow seismic survey methods at this site to delineate the structures and stratigraphy. The introduction of acoustic energy into the ground in a controlled fashion involves equipment or material with the potential to do harm if not properly handled and operated. Good common sense, training, and experience are the rule for seismic field operations. These can usually be easily accomplished if manufacturers' operating and use instructions are followed.

The field investigations will involve project personnel performing geophysical surveys of the study area utilizing the aforementioned pressure pulse, impacting, and vibratory seismic sources. The principal hazards associated with the use of sources mentioned here consist of handling or moving the equipment, improper use, fragments from high pressure impacts, and elevated sound levels.

VII. ACTIVITY HAZARD ANALYSIS

A. Work Item: Traffic Control

All regulations concerning right-of-way and traffic directions will be observed.

Specific Hazards—The specific hazard involves accidents with vehicular traffic within the survey area.

Control Measures—All personnel will minimize activity along trafficked roadways to the extent possible. Traffic cones will be used to identify and buffer the work area with respect to on-coming traffic. Care will be used while working on or around driveways. If appropriate, signs and/or flagmen will be used to alert and slow traffic through the survey area. Flagmen will be used along roadways with limited sight areas or speed limits exceeding 45 mph. For sites with traffic speeds above 45 mph and work requiring shoulder access, lane closure must be considered.

B. Work Item: Use of Class “C” Shotgun Ammunition (Auger gun / Buffalo gun / 50 cal. / 30.06)



Specific Hazards—The specific hazards involve injuries to persons or property damage arising from normal or accidental detonation or improper handling of the shotgun ammunition.

Control Measures—All project personnel working with or around the shotgun ammunition, seismic guns, and associated equipment will exercise all appropriate and reasonable precautions to prevent or limit accidents arising from use of explosives. All explosive devices

will be Class “C,” consisting of fully containerized smokeless black powder in the form of shotgun ammunition. Site work will conform with appropriate and reasonable Class “C” explosives handling, storage, communication, and detonation procedures. All seismic shots will occur in shallow boreholes 2 to 4 feet below ground level.

Rick Miller of the Kansas Geological Survey will be responsible for the safe use of shotgun ammunition to be used. He will review the blasting communications and safety procedures at the initial site safety meeting and again prior to the initiation of the first seismic shots. All project personnel must become familiar with and abide by these protocols.

Specific shotgun ammunition safety measures when KGS is managing ammo are as follows:

- Storage: All shotgun ammunition will be stored in a locked metal container. The storage container will have proper DOT labels for Class “C” shotgun ammunition.
- Transportation: The ammunition vehicle will carry proper DOT labels and will be operated by **Rick Miller** on or near site. The vehicle will contain a fire

extinguisher, First Aid kit, and will be parked far enough off any road to minimize the potential for a collision with other vehicles.

- Handling: Only **Rick Miller** or qualified alternate, KGS, will be allowed to access, handle and load the shotguns. Shotgun loading and firing will be conducted in accordance with the attached “Operations/Safety Rules and Regulations for the Auger Gun.”
- Firing Communication: **Rick Miller** shall establish a series of warning signals to be used prior to and following each shot. An audio signal or voice command will indicate the beginning of a shot (or prior site specified requirements). He will review the precise warning procedures with all project participants at the initial site safety meeting, and will monitor compliance with these procedures.
- Safe Distances: All project personnel not authorized to handle the shotgun ammunition and guns must stay a distance of 10 feet away from the guns and shot locations. Non-project personnel will not be allowed in the work area.

Blasting shall not commence if any of these protocols is not met.

Ammunition safety measures on-site are the responsibility of [Agency] demo staff. The previous protocols are KGS minimums and can serve as fallback measures if site staff do not have more stringent requirements.

Transportation—Transportation of the auger guns and ammunition is on a standard 2-ton flatbed truck and enclosed gooseneck trailer. The ammunition is carried in .50-caliber military-style ammo boxes. The ammo boxes are locked in 10-gauge steel boxes that are permanently bolted to the truck bed. The ammunition is classified as “Class C Explosive” by the U.S. Department of Transportation. No more than 2,500 rounds of ammunition will be transported to this project, packed in quantities of around 160 per container.

C. Work Item: *Modified Auger Gun*

Specific Hazards—Detonation outside downhole environment, crush by motorized-moving vehicle, and hand entanglement in moving parts.

Control Measures—

- 1) Safe gun practices (detailed in supporting documents),
- 2) care and inspection of firing mechanism,
- 3) only load shell immediately prior to downhole insertion,
- 4) maintain at least 10 ft separation from vehicle when moving, and
- 5) maintain minimum 5 ft standoff distance from source when under hydraulic power.



D. Work Item: Downhole .50-cal.



The downhole .50-caliber seismic source consists of a .50-cal. rifle bolted to a 0.6 cm thick steel plate. The rifle itself is a standard .50-cal. breech and bolt, built by Texas Gun and Machine Company, attached to a standard .50-cal. machine gun barrel. Machined

grooves in the barrel are used in conjunction with a pressure clamp to attach the rifle to a 30 cm by 90 cm steel plate. The rifle barrel is lowered into a 60 cm to 80 cm deep borehole 4 cm in diameter until the plate is flush with the ground surface. This steel plate acts as a ground seal and a platform to stand on while firing the gun. The

weight of the shooter on the plate and the snug fit of the barrel to the borehole walls help seal the gun to the ground. The rifle can be equipped with a source sensor or closure switch to generate a time break. Firing can be done either electrically by solenoid or manually by pulling the trigger. The downhole .50-cal. weighs about 30 kg and is easily two-person portable. Safety rules for the use of the .50-cal. seismic gun are presented as an appendix to this plan.

Specific Hazards

- 1) Above ground detonation
- 2) Plugged barrel and barrel chamber rupture
- 3) Pinch appendages between bolt and breech
- 4) Drop live shell and freak detonation outside chamber
- 5) Back strain from improper lifting of source

Control Measures

- 1) Use good gun sense (detailed in appendix)
- 2) Never transport with bolt in locked position
- 3) Never transport with shell (live or spent casing) in chamber
- 4) Keep barrel clear of all foreign material
- 5) Use condom to insure fluids do not gain access to barrel
- 6) Two people lift from handles using bent knees and straight backs

E. Work Item: Bolt LSS-6 Land Air Gun

The Bolt Land Air Gun has been in routine use in oil exploration for more than 20 years. The device consists of a 3-cylinder diesel engine, a four-stage air compressor, and an enclosed water filled chamber (housing the “gun”). The safe operation of the gun is well documented in the operator’s manual. The entire device is transported as the bed of an F-350 4-wheel drive truck. The 3-cylinder diesel engine powers not only the air compressor but also a hydraulic system designed to



raise and lower the gun chamber to the ground. The gun chamber is hydraulically lowered to the ground with the weight of the truck used to hold the device to the ground. The gun is electrically detonated from the cab of the truck with no moving parts exposed during detonation. The engine and air compressor are enclosed in a protective shroud. The gun generates a thump to the ground surface approximately equivalent to 1/8 of a pound of high explosive buried 3 to 4 ft beneath the ground surface.

Specific Hazards

- 1) Reckless use of transport truck
- 2) Air line rupture
- 3) Pinch or smashed appendages during raising or lowering of tower.
- 4) Arm or hand entanglement in belt driven compressor.
- 5) Rupture of diaphragm
- 6) Hearing loss from diesel engine
- 7) Compressed air cylinder breach

Control Measures

- 1) The careful and safe operation of the standard 4-wheel drive truck is well documented in the owner's manual.
- 2) It is critical to always be aware of anyone near the device.
- 3) The raising of the gun for transport and lowering of the gun just prior to detonation is done with only part of the gun visible to the operator. It is critical that no one comes within 50 ft of the gun while in operation.
- 4) Hearing protection (down 30 dB) is required by anyone within 50 ft of the truck.
- 5) Keep all shields in place and moving parts serviced.
- 6) Daily inspect all air lines and connectors holding pressures in excess of 500 psi.

F. Work Item: *MiniVib*

The MiniVib is a hydraulically powered vibrator designed to shake the ground in a very controlled fashion over about a 4 to 8 second time duration. The device is hydraulically powered with no moving parts that possess an entanglement potential. Energy is delivered to the ground by this device through a hydraulically powered pad approximately 3 ft in diameter mounted on the belly of the vehicle. The pad is lowered from beneath the vehicle using the vehicle's weight as hold-down pressure. The pad is vibrated by a hydraulic servo delivering frequency-varying energy to the plate over a preset time duration. No moving parts are exposed with the maximum movement of the pad relative to the vehicle less than 2 in.



Specific Hazards

- 1) Crush hazard for anyone near baseplate or wheels when turning steering wheel.
- 2) Hydrostatic drive responds differently than standard mechanical drivetrains, making personal injury from rolling over possible.

- 3) Center-articulating vehicles can easily roll over on steep side hills when turning uphill.
- 4) High pressure accumulators, pumps, motors, and transmission lines can rupture, spew hot oil and, if in physical skin contact, fluid can be injected under the skin.
- 5) Mass moves at extremely high rate of speed and if valve malfunctions, mass can slam into stops, potentially crushing any appendage between the mass and stops.
- 6) With 15,000 lbs. of down pressure on baseplate, baseplate can crush.
- 7) Vehicle has no suspension and therefore at top speed (15 mph) driver can be tossed into ceiling on bumpy roads.
- 8) Vehicle's diesel engine is exposed with the fan belt and pulleys moving at a high rate of speed when operating.

Control Measures

- 1) This vehicle is center articulating and requires care when turning that no one is within 20 ft of the vehicle and no sharp turns are made on steep hill sides.
- 2) Safe operation of the vehicle is documented in the operator's manual provided by the manufacturer.
- 3) Hearing protection is required within 50 ft of the vehicle.
- 4) All shields are to remain in place while the vehicle is in operation.
- 5) Hydraulic pressures of more than 3000 psi are routine during operation. No maintenance or service will take place while the vehicle engine is running.
- 6) Quick inspection is necessary prior to lowering the pad.
- 7) Switch to low pressure setting when operator is not in cab.

G. Work Item: Downhole Firing Rod

The downhole firing rod is a 4 ft long pipe with a sleeve designed to hold and contain a shotgun type shell. Gauges can range from 8 to 12. The sleeve holds the shotgun shell, which for seismic applications is routinely a black powder blank. Once a ~3ft deep hole, 2" in diameter is drilled the firing rod is lowered into the hole and the hole is fluided with water. Water acts to improve dissipation of energy and partially contains the upward directed energy. After the source is properly loaded into the borehole a firing rod impacts the primer of the shotgun shell via firing rod that extends through the center of the pipe. Accelerating this firing rod inside the pipe is accomplished with a rubber mallet by impacting the top of the rod. The mallet is instrumented with a contact closure device that acts as a time zero indicator.



Specific Hazards

- 1) Detonation above ground
 - a. Detonation while loading sleeve.
 - b. Detonation while screwing sleeve onto rod.
 - c. Detonation while lowering into borehole.
- 2) Air blast from source detonated downhole without water cover.
- 3) Recoil of rod projecting it out of hole and into air.

Control Measures

- 1) Operate firing rod in compliance with manufacturer's instructions.
- 2) Insure (double check) firing rod is locked in place prior to screwing sleeve onto rod.
- 3) Shell should load into sleeve with gentle pressure, otherwise change shells.
- 4) Add water until running onto ground surface.
- 5) Inspect to ensure water is in annular space around firing rod prior to unlocking firing rod
- 6) Weight firing rod to counter recoil energy

H. Work Item: *Accelerated Weight Drop*



The accelerated weight drop (AWD) generates acoustic energy by accelerating a 50 to 100 lb weight through a 2 ft stroke impacting an 18 in diameter steel plate held to the ground surface by the weight of a skid-steer style loader. The weight is accelerated within an enclosed steel guide. The drive mechanism consists of a hydraulic motor turning a set of sprockets that deliver power to a cycling lift arm that pulls the weight against the resisting force of an industrial rubber band. Simply envisioned, this device is analogous to a slingshot. All

moving parts are shielded, with the contact area between the weight and plate sufficiently enclosed to avoid the possibility of debris becoming airborne and representing a risk to the operator or bystanders. The winch located at the back of the Toolcat is a standard winch in a custom-built bracket. The bracket serves two purposes: 1. To protect bystanders during operation, and 2. To protect the winch itself. The bracket has a fairlead consisting of four rollers; the top roller slides up and down during operation. When the roller slides upward it trips a switch that kills the power to the winch immediately. The reel located in the bed of the Toolcat (which holds the land streamer when not in operation) is a custom-built belt-driven reel with an electric motor. The controls for the motor are located at the back end of the Toolcat bed to ensure safe operation for the operator. The belts and pulleys are located on the inside of the bed and are shielded from bystanders by the support structure of the reel itself.

Specific Hazards

- 1) Roll over on steep terrain possible with loader carrying weight drop in elevated position.
- 2) Hearing damage from impact of hammer and anvil
- 3) Entanglement of operator in streamer wench
- 4) Entanglement in streamer reel
- 5) Running over and crushing feet under wheels
- 6) Collision with traffic when working along roads.
- 7) Hydraulic fluid leak or high-pressure release

Control Measures

- 1) The operator wears hearing protection (30 dB down) while the loader is running.
- 2) No bystanders can be within 30 ft of the device while it is in operation and within 50 ft without hearing protection.

- 3) All shields are to remain in place while in operation. Routine maintenance, requiring removing shields, can take place only when the loader engine is off.
- 4) The operator can exit the vehicle only when the weight drop is in the full down position and solid contact is made with the ground surface.
- 5) Operation of the Toolcat will be consistent with those published in the owner's manual.
- 6) The fully bracketed winch keeps extremities away from moving parts.
- 7) The emergency kill switch on the reel, when triggered, cuts power to the reel motor immediately.
- 8) The reel's pulleys and belts are installed on the inside of the support structure of the reel to separate the crew and the belts while in operation.
- 9) All controls of the winch are located in the cab of the Toolcat, which limits control of the winch to just one person, the operator of the Toolcat.
- 10) Operating power to the winch and reel can be cut from the cab when not in use or when the operator feels it is necessary.
- 11) The Toolcat is to be operated by only a qualified trained individual.
- 12) Only move Toolcat when weight drop is carried low to maintain low center of gravity and minimize tip-over risk.
- 13) Operate along road shoulders with proper traffic safety precautions and with hazard lights flashing.

I. Work Item: All Terrain Vehicles/Utility Vehicles (UTVs)



UTVs that could be on site include the 4x6 John Deere Gator and three Polaris 4x6s. These UTVs all serve a very specific purpose and are critical to smooth and efficient operations. UTVs never obtain speeds in excess of 15 mph and therefore do not represent risk of injury due to excessive speeds. The tip-over potential is minimized by the 6-wheel design of the vehicles, but tip-over potential does exist. Care is always taken to properly load the vehicles and only traverse grades within the acceptable limits of the vehicle as defined by the manufacturer.

1) The Yamaha has a specially designed cable winding device (not used for this survey). The Yamaha has a Power Take-Off that is used to power a winding device mounted on the front of the vehicle and is used for the rolling of seismic cable. Operation of the PTO requires the operator to be on the seat and traveling in the lowest speed range (this is controlled by safety overrides that "kill" the engine when these conditions are not met).

2) The Gator is designed to carry seismographs and 12-volt batteries. This vehicle never travels more than 10 mph and spends over 99% of its time parked along the survey line.

3) The Polaris is the primary work horse of the UTVs. It transports cables and geophones in a 3x3 steel box mounted behind the seat. The vehicle has 6 wheels with 4 drive wheels. The 6-wheel design makes the vehicle very stable with a large safe payload capacity (>700 lbs). This vehicle never travels more than 15 mph and is therefore at low risk of injury from excessive speed.

Specific Hazards

- 1) Roll over at high speeds.
- 2) Roll over while operating in reverse.
- 3) Run over observers or co-workers.
- 4) Loss of control with heavy loads
- 5) Brake failure
- 6) Collision with other vehicles, especially automobiles when working along road sides

Control Measures

- 1) Every UTV operator shall possess a valid Kansas driver's license and shall have completed an appropriate training course prior to operation of the vehicle. The following persons have training and authorization to operate the UTVs: ***Rick Miller, *Brett Wedel, Brett Bennett.** *Authorized trainers.
- 2) The manufacturer's recommended payload shall not be exceeded at any time.
- 3) Gloves, eye protection, and an approved motorcycle helmet shall be worn at all times while operating a UTV at speeds in excess of 15 mph.
- 4) UTVs are to be used to haul equipment and supplies only.
- 5) Only UTVs with **four / six** or more wheels are permitted to be used.
- 6) All UTVs shall be equipped with a warning signal device (horn).
- 7) UTVs will be operated and maintained in accordance with the manufacturer's operating manual.

J. Work Item: Slide Hammer and Sledgehammers



A sledgehammer is a large metal mass, elongated and fitted to a wood or fiber shaft.

Slide hammers are custom made and designed to accelerate a weighted hammer along a fixed guide and impact a contained anvil. A slide hammer is normal much less energetic than a sledgehammer but the moving parts are all contained and all motion is in the vertical plane. A sledgehammer is a symmetric weight mounted to the end of a handle made of wood, vinyl, or plastic and accelerated by swinging through an arc that ends with contact on a striker plate. A sledgehammer is completely disconnected from the striker plate while the slide hammer and striker plate are connected.

Specific Hazards–

- 1) Uncontrolled swing and fragmenting of hammer or plate or handle/mass failure.
- 2) Glancing impact of striker plate
- 3) Tangled in time zero cable

Control Measures–

- 1) Only experienced operators,
- 2) power hammer into ground at a controllable level.
- 3) no bystanders within the distance of two hammer handle lengths side-to-side and behind and 25 ft in front.
- 4) Keep time zero cable securely taped to hammer handle from head to heel of handle.
- 5) Keep time zero cable behind operator and away from striker plate.
- 6) Wear appropriate safety gear; eye protection, steel toe boots, and eye protection.

K. Work Item: *Geophones and Land Streamer*

Geophones are electromechanical devices that respond to earth movement, producing an electric pulse representative of the ground motion. They are coupled to the ground with 3–5-inch spikes. The land streamer is a collective group of geophones connected by a single belt and dragged along the ground surface, maintaining pressure contact with the ground.



Specific Hazards

- 1) Geophone spikes can puncture the skin and a string or groups of geophones can be excessively heavy and represent a lifting hazard.
- 2) The land streamer is large, heavy, and awkward to handle. Muscle strains and pulls are possible.
- 3) Land streamer is transported on a reel mounted in the bed of the Bobcat Toolcat. The streamer is reeled on and off with an electric motor with a safety switch. Operator can get tangled in streamer and pulled into reel.



Control Measures

- 1) Keep geophone strings away from legs while walking and carrying.
- 2) Never carry more than one hasp of geophones per arm.

- 3) Always bend knees and use proper lifting techniques when loading or unloading land streamer.
- 4) Wear gloves and safety shoes to protect extremities from smash or crush hazards.
- 5) Always operate streamer pick-up reel within arm's length of speed regulator and safety shut off switch.

L. Work Item: *Paintball Impulsive Seismic Source*

Specific Hazards—Uncontrolled release of pressurized air.

Control Measures—Store cartridges in a secure area and keep full cartridges separated from empty. Installation of cartridges will be done with appropriate safety gear including gloves, earplugs, and safety glasses. Canisters will be kept closed and always pointed away from operator.



M. Work Item: *Microvibrator*

Specific Hazards—Electric shock.

Control Measures—Operator will have an assistant responsible for moving, untangling, and general care of the electric power cord.

N. Work Item: *Hole Lock Geophone*

This downhole device contains three passive sensors contained in a stainless-steel tube. A 36 V screw-style electric motor extends and contracts a ½" diameter band that acts to form a pressure contact with the walls of a borehole.

Specific Hazards—pinch from extraction or contraction of steel band outside borehole.

Control Measures—borehole clamp will only be operated when tool is in a cased borehole. The device can be and should be tested at the top of the borehole, within the view of the operator, to ensure the system is working properly. The tool will not be operated outside the borehole.



O. Work Item: ASI Platform

Specific Hazards –

- Loading/Unloading
- Hydraulic cylinders
- Crush beneath loader/bed.
- Backing/driving over
- Raising/lowering bed
- Electric motor driving pick-up
- Streamer dropping over roller.
- Lifting and pulling streamer over pickup reel
- Weight Drop chain or hydraulic line breaking/bursting
- Loud noise from operation
- Tripping hazard from extension cable/tension system
- Smashing/pinching from streamer.
- Tension system entangles hands or feet.



Control Measures - The weight drop front platform is attached while the personnel are 3 ft clear of connecting points. While the streamer is being loaded/unloaded the operator is standing on the ground clear of the pickup reel and the streamer as it is exiting the bed. If there is a need for a second person during loading, they will be in the bed of the Toolcat clear of the pickup reel. When work needs to be done at the front end, all personnel are required to stand 3 feet back from the loader. While work is being done a stop for the hydraulic cylinder is used (when available) or use of a spotter to assess hydraulic “bleed off”. Spotters are to be used when backing up, all other personnel are required to stand back 20 feet while this is happening. While moving forward all personnel are required to stand back 20 feet. When the bed is raised for work on the engine, the stops are used. The electric motor used to drive the pickup reel is covered by a safety cage. The streamer pickup reel has raised edges to keep the streamer on the reel. The rubber paddles allow the speed of the streamer pickup and deployment to be controlled. The weight drop is covered by a safety cage to keep personnel away from moving parts and to protect personnel if the chain breaking or hydraulic hose bursts. Any personnel within 6 feet of the operating weight drop are required to wear hearing protection. Personnel are required to be 10 feet back from the tension system/extension cable during operation. This distance keeps personnel’s feet and hands clear of entanglement. This distance also allows for a safe operating zone in case of a rope break causing a snap back.

P. Work Item: Generators

Specific hazard

- Burn from exhaust.
- Electric shock

Control Measures - Exhaust pipes are in areas away from normal work areas. If work needs to be done near exhaust, generators are required a minimum of 20 minutes to cool until work can be done.

To avoid electric shock, any work on generators are required to be done while the engine is not running and battery (if applicable) is disconnected.



P. **Work Item: Loading and Unloading and Hauling Equipment**

Specific Hazards –

Tommy Lift

Smashing from deck flipping over

Pinch between deck and lift arms

Pinch between deck two sections of deck

Hydraulic leaks

Driving on and off

Driving off ramps and deck of trailers

Pinch point between ramps and deck

Smashing from ramps being lowered

Strapping

Straps breaking or breaking free

Excess strap getting caught in wheels

Loose straps

Connecting points cannot hold hooks



Control Measures – Tommy Lift will be operated while personal are clear of operating area. The Tommy Lift has a wired remote control allowing the operator to be clear of the operating area. Designated spotters are used when equipment is being loaded or unloaded onto trailers. The unloading zone is clear of all personnel except for the driver of the vehicle and designated spotter(s). All personnel are required to be back 6 feet from the loading/unloading zone while the ramps are lowered and raised. All equipment is secured down using the amount of and rated straps or chain binders for that specific equipment's requirements. Strapping down equipment will involve 2 personnel, one on each end of the strap. This will ensure that the hooks on both ends of the strap will be secured to their respective anchor points properly. The loose excess strap and/or extra chain is secured using tape, wire, etc.

Q. **Work Item: Batteries**

Specific Hazards – Leakage and the arcing of the battery posts
Weight
Moving during transport



Control Measures – Batteries are transported on a pallet, upright, and strapped together. All potential arcing metal materials are not transported in the same vehicle as the batteries to avoid the chance of arcing. Batteries (47lbs) are to be lifted using the proper lifting technique. To avoid leakage: batteries are stored, transported, and used while upright.

R. **Work Item: GPS Tripods and Unit**

Specific Hazards – Sharp pointed tips of the range pole and tripods.

Control Measures – Tripods and Range pole are loaded and unloaded so that the tips are away from personal.



VIII. TRAINING

At least one KGS personnel working at the site in connection with the project shall have received hazardous waste worker training in accordance with 29 CFR 1910.120(e), be certified in First Aid, all operators of UTVs will have completed approved training, and CRP trained. This includes 40-hour initial training and yearly 8-hour refresher training. All operators of UTV's will have completed approved training. All KGS personnel will have appropriate experience and training with each source, vehicle, and method used.

IX. PERSONAL PROTECTIVE EQUIPMENT

Personal protective equipment (PPE) protects employees from the hazards and potential hazards they are likely to encounter as identified during previous site characterization activities. PPE consists of a combination of protective clothing and respiratory protection equipment. Selection of PPE is based on an evaluation of the performance characteristics of the PPE relative to the requirements of the site and the task specific conditions and duration. The level of protection is upgraded when site monitoring or conditions indicate that increased protection is necessary to reduce employee potential for exposure.

Based on the available information assessing the current condition of the sites, minimal skin protection is required for general access. The prescribed working uniform for all personnel engaged in activities related to the project is a modified EPA level D and shall consist of:

- Long-sleeved shirts and full-length pants
- Leather steel toed safety boots
- Hard hat* (only necessary for certain operations)
- Eye protection*
- Hearing protection as required by OSHA for certain tasks (identified by work item)
- Orange vests along roadways

No respiratory protection equipment is required. At the present time based on all available information, the atmosphere contains no known hazards. There is no expected potential for inhalation or contact with hazardous levels of any chemical.

Added protection from the sun and insects might be necessary. All workers will be encouraged, but not required, to use sunscreen and insect repellent available in covered trailer. These protective chemicals will be available for use on-site.

*When operating sledgehammer, slide hammer, 30.06 projectile, and auger gun.

*When operating sledgehammer or paintball source.

X. SAFETY ANALYSIS

The following analysis list postulates hazards, consequences of those hazards, and the means of prevention or mitigation of each hazard associated with this survey activity.

A. Mobilization – Loading & Unloading

<i>Potential Hazards</i>	<i>Recommended Safe Procedures</i>
Sprained back	Use proper lifting technique, get help
Backing vehicle into equipment or personnel	Use spotter, back-up alarms on vehicles. Driver to insure that rear-view mirrors are adjusted properly.

B. Mobilization – Travel To / From Site

<i>Potential Hazards</i>	<i>Recommended Safe Procedures</i>
Traffic accidents	Use proper defensive driving technique.
Livestock or other animals on road	Watch sides of the road, especially at dawn & dusk; try to avoid larger animals.
Equipment falling off of trucks	Check load before leaving shop or overnight lodging, after first 25 miles, then after every 150 miles.
Losing control or falling asleep at the wheel	Watch driving speed versus road condition and posted legal limits. Get good rest, use buddy system on long drives, pull over if necessary.

C.1 Vibroseis Operations – See also IAGC Manual

<i>Potential Hazards</i>	<i>Recommended Safe Procedures</i>
Vibrating over buried natural gas, electric, or telephone lines	Use utility location if needed before commencing work. Look for posted notices of buried utilities.
Lightning in area	If thunder is within 5 seconds of lightning, shut down operations, get into truck cab.
Slips, trips, falls	Clear work area of obstacles, be sure of your footing.

C.2 – Sledgehammer

<i>Potential Hazards</i>	<i>Recommended Safe Procedures</i>
Handle breaking/head coming off	25ft “clear zone” in front of the operator while hammer is being used.
Slips, trips, falls	Clear work are of obstacles, be sure of your footing

C.3 – Downhole auger

<i>Potential Hazards</i>	<i>Recommended Safe Procedures</i>
Drilling over electric or telephone lines	Use utility location if needed before commencing work. Look for posted notices of buried utilities.
Pinch point or wrap up point	All other personnel are to stay back 6 feet while the downhole auger is being used

C.4 – Weighted Drop

<i>Potential Hazards</i>	<i>Recommended Safe Procedures</i>
Use over buried natural gas, electric, or telephone lines	Use utility location if needed before commencing work. Look for posted notices of buried utilities.
Pinch points	Personnel will stay 6 feet back when equipment is being attached and during operation.
Hearing Exposure	All personnel within 6 feet of the weight drop during operation are required to wear hearing protection.

D. Working Along Highways – This section highlights the more common issues. It is not meant to be a guide to traffic control, which should be conducted only by qualified personnel. Traffic signs, cones, and flaggers should be used as appropriate when working on road shoulders. Signs, cones, and flaggers must be used when working in a closed traffic lane.

<i>Potential Hazards</i>	<i>Recommended Safe Procedures</i>
Pedestrian/ Automobile accident	Wear high-visibility vests. Watch traffic. Don't assume traffic control will keep cars & trucks out of area. Work <u>facing</u> traffic, <u>not</u> back to traffic. If traffic drifts into the lane you are working in, <i>drop what you are doing and get away to safety.</i>
Slips, trips, falls	Clear work area of obstacles, be sure of your footing.

E. Laying Out and Picking Up Seismic Cables and Geophones

<i>Potential Hazards</i>	<i>Recommended Safe Procedures</i>
Slips, trips, falls	Clear work area of obstacles, be sure of your footing.
Back or neck injury	Get assistance with heavy cables, use proper lifting technique.
Tangled cables	Use proper winding / unwinding technique, get help with untangling heavy cable or untangling cable where footing is slippery or steep.
Lightning in area	If thunder is within 5 seconds of lightning, get away from cables, shut down operations, disconnect cables from any recording equipment mounted in truck, get into truck cab. Keep an eye on the weather if thunderstorms are forecast.

E.1 Laying Out and Picking Up Seismic Cables and Geophones

<i>Potential Hazards</i>	<i>Recommended Safe Procedures</i>
Slips, trips, falls	Clear work area of obstacles, be sure of your footing.
Back or neck injury	Get assistance with heavy cables, use proper lifting technique.
Tangled cables	Use proper winding / unwinding technique, get help with untangling heavy cable or untangling cable where footing is slippery or steep.
Lightning in area	If thunder is within 5 seconds of lightning, get away from cables, shut down operations, disconnect cables from any recording equipment mounted in truck, get into truck cab. Keep an eye on the weather if thunderstorms are forecast.

E.2 – Laying out and picking up nodes

<i>Potential Hazards</i>	<i>Recommended Safe Procedures</i>
Slips, trips, falls	Clear work area of obstacles, be sure of your footing.
Back or neck injury	Get assistance with heavy cables, use proper lifting technique.
Lightning in area	If thunder is within 5 seconds of lightning, get away from cables, shut down operations, disconnect cables from any recording equipment mounted in truck, get into truck cab. Keep an eye on the weather if thunder storms are forecast.

E.3 – Planting geophones

<i>Potential Hazards</i>	<i>Recommended Safe Procedures</i>
Slips, trips, falls	Clear work area of obstacles, be sure of your footing.
Back, neck, or foot injury	Get assistance with heavy cables, use proper lifting technique. Wear proper PPE (steel toed boots)
Tangled cables	Use proper winding / unwinding technique, get help with untangling cable where footing is slippery or steep.
Lightning in area	If thunder is within 5 seconds of lightning, get away from cables, shut down operations, disconnect cables from any recording equipment mounted in truck, get into truck cab. Keep an eye on the weather if thunder storms are forecast.
Spikes on geophones	Being aware of spike on end of geophone while loading/unloading phones from boxes. Also be aware of spike while planting phone

F. Environmental Concerns

<i>Potential Hazards</i>	<i>Recommended Safe Procedures</i>
Fuel & hydraulic fluid leaks	Check equipment for leaks and repair as needed. Use absorbent materials, clean up any spills.

XI. ENVIRONMENTAL IMPACT ANALYSIS

The environmental impact of this activity has been evaluated and determined minimal (“small footprint”) at more than six U.S. Government facilities (Y-12 ORNL, Oak Ridge, TN; WAG-10, ORNL, Oak Ridge, TN; Paducah Gaseous Diffusion Plant, Paducah, KY; Nevada Test Site, Las Vegas, NV; Fort Ord, CA; Berkeley National Lab, Berkeley, CA; INEL, Idaho Falls, ID) as well as multiple BLM and DOD sites.

XII. HANDLING AND DISPOSAL OF UNEXPLODED ROUNDS

The handling of live ammunition will be in complete compliance with sections VIII.A and B and seismic gun operation procedures (both sections of this report). In the event a round does not detonate using standard operating procedures, the seismic source will be left in place undisturbed for a minimum of 3 minutes. After this initial 3 minutes, the shell will be extracted to ensure minimal contact with operators. The unexploded round will be placed in the metal container used for the storage of spent rounds. If the round is an 8-gauge it will remain in the sleeve for a minimum of 20 minutes after placement in the metal can prior to being placed in a metal can and locked in the steel containers attached to the truck. If it is a 50-cal. round it will remain in the can for 20 minutes before it will be removed and re-stored in a metal can in the metal transport boxes attached to the truck. The unexploded rounds will then be delivered to __[Agency]__ demolitions staff for disposal by __[Name]__.

XIII. REFERENCES

Applicable portions of the following documents form the basis for this safety plan.

From the United States Department of Energy:

DOE Order 5480.16, *Firearms Safety*.

DOE Report DOE/EV/06194-3, *DOE Explosives Safety Manual*.

ID Appendix 0550, *Standard Operational Safety Requirements*, Part III, Subpart I, “Explosives”

From the United States Department of Defense:

DOD 6055.9-STD, *Ammunition and High Explosive Safety Standards*

AR-385-63, *Safety Policies and Procedures for Firing Ammunition for Training, Target Practice, and Combat*

Safety Analysis of Projectile Seismic Sources

Potential Hazard	Consequences	Mitigation/Prevention Mechanism
Lost/Stolen Ammunition	Personal Injury or property damage from unauthorized use	Implement system to issue daily ammunition allotment. Control inventory, physical control of ammunition at all times
	Loading/Unloading	
Dropped cartridge	Personal injury from accidental discharge	Assure training of personnel in proper handling of live ammunition
Introduction of foreign material into breech or barrel	Damage to barrel, breech or bolt and resulting personal injury	Assure training of personnel in proper handling of ammunition and in-process inspection of ammunition and seismic gun
	During Firing	
Muzzle Air Blast	Personal injury from flying rocks, soil, debris	Close fit of barrel in boreholes suppresses muzzle air blast and its effects
Ricochet	Personal injury from ricocheting projectile or fragments	Design and use of seismic gun prevent the escape of projectile or fragments from the borehole with sufficient energy to cause personal injury
Flash burns	Burns from muzzle flashes	Discharge into earth or containment device suppresses muzzle flash
Misfire	Personal injury from subsequent accidental discharge of misfired round	Assure training of personnel in proper handling and disposal of misfired ammunition

Safety Analysis of Projectile Seismic Sources

Potential Hazard	Consequences	Mitigation/Prevention Mechanism
Accidental discharge of seismic gun	Injury to unintended target	Assure that operating procedures prevent transport of loaded seismic gun
Plugged barrel - dirt	Damage to barrel and resulting personal injury	Assure that operating procedures include thorough bore sighting between shots and/or probing with dowel after installation in borehole
Plugged barrel – water	Damage to barrel and resulting personal injury	Assure that operating procedures require inspection of boreholes for water
Barrel disengagement from plate	Personal injury to crew members by flying rifle	Implement an inspection/maintenance procedure for the barrel to plate attachment
Breech disengagement from barrel	Personal injury to crew members by flying breech and bolt groups	Implement an inspection/maintenance procedure for the breech to barrel attachment
	During loading/ transport	
Accidental discharge	Injury to unintended target	Assure that operating procedures permit loading only after seismic gun has been installed in borehole
Accidental drop or collision	Damage to barrel or firing mechanism	Assure that the operating/transportation procedures require thorough inspection of seismic gun after drop or collision incidents. Seismic gun is disassembled and stored in special compartment during vehicular transport

TRAINING OUTLINE FOR USE OF SEISMIC GUNS

“GOOD GUN SENSE”

A. TRANSPORTING (vehicle, on foot, etc.)

1. In the field:

Always point down or away from populated areas

Always avoid lodging foreign material in barrel

Never strain to carry, get a second person

Make no assumptions.

2. To and from site and storage:

Storage must be in a metal locked container.

Bolt and gun must be stored in separate locations.

Guns must be fully broken down and cleaned prior to storage.

Access to guns limited to trained personnel.

Live rounds must not be stored less than 5 ft from guns.

B. CLEANING

1. Daily:

Must be inspected for unusual wear, signs of metal fatigue or structural weakness at the beginning and end of each day's service.

Bolt and breech must be oiled and checked for mechanical operation at the end of each half day service. The barrel will be carefully inspected and checked for signs of fatigue.

The bolts that secure the gun to the protective steel plate must be checked and least 3x/day.

2. Seasonal:

R/R springs in extraction system and those associated with the firing rod.

R/R bolts and nuts that attach to protective steel plate.

R/R mounting bracket as necessary

C. FIRING

1. Assumptions: NONE

2. Never:

Move from downhole placement with shell in chamber

Have a gun loaded without someone standing on plate

Have only one person standing on plate

Fire with knees locked

Extract a shell in less than two minutes that has not detonated

Fire without both operators aware of detonation

Drop a loaded round

Return a misfire to live round canisters

