

**KANSAS GEOLOGICAL SURVEY
OPEN-FILE REPORT 96-20**

**DETECTION OF LOW-PERMEABILITY WELL SKINS
USING SLUG TESTS**

by

J. J. Butler, Jr.
J. M. Healey

Disclaimer

The Kansas Geological Survey does not guarantee this document to be free from errors or inaccuracies and disclaims any responsibility or liability for interpretations based on data used in the production of this document or decisions based thereon. This report is intended to make results of research available at the earliest possible date, but is not intended to constitute final or formal publications.

Kansas Geological Survey
1930 Constant Avenue
University of Kansas
Lawrence, KS 66047-3726

Detection of Low-Permeability Well Skins Using Slug Tests

James J. Butler, Jr., and John M. Healey
Kansas Geological Survey
1930 Constant Avenue, Campus West
University of Kansas
Lawrence, KS 66047

Prepared for presentation at
The American Geophysical Union
Spring Meeting in Baltimore, Maryland
May 20, 1996

KGS Open File Report #96-20

ABSTRACT

The failure to recognize the existence of a low-permeability well skin is undoubtedly the largest source of error in hydraulic conductivity (K) estimates obtained from slug tests. An underestimation of formation K by an order of magnitude or more will often be the result if the presence of a low-permeability skin is not recognized. In this presentation, several approaches for the identification of low-permeability well skins are discussed. Special emphasis will be placed on a new approach that has recently been proposed for use in formations of low to moderate K . This approach exploits some basic features of the physics of slug-induced flow in the presence of a low-permeability skin. Repeat slug tests are performed in conjunction with a simple ratio method derived from the Hvorslev technique. The dimensionless storage parameter is changed between tests by modifying the effective radius of the well casing. Results indicate that the approach should work well when the skin-formation K contrast is greater than an order of magnitude, even in the presence of the noise inherent in field applications. Less dramatic contrasts can be identified when the vertical component of the slug-induced flow is small and/or the change in the effective casing radii is quite large. Although the formation K may still be difficult to estimate, use of these methods should enable the field practitioner to avoid inadvertently assigning properties reflective of a low-permeability skin to the formation.

INTRODUCTION

The slug test is a commonly used technique for the in situ estimation of hydraulic conductivity at sites of suspected groundwater contamination (Chirlin, 1990; Butler et al., 1996). This approach consists of measuring the recovery of head in a well after a near instantaneous change in water level at that well. The recovery data can be used to estimate the hydraulic conductivity (K) of the formation through comparisons with theoretical models of test responses. The widespread use of this technique cannot be overemphasized, as literally tens of thousands of these tests are performed each year in the United States alone.

Unfortunately, estimates obtained from slug tests are often not consistent with other information obtained as part of a site investigation. For example, a large body of field data shows that the K estimate obtained from a series of slug test is, on average, considerably lower than that obtained from pumping tests in the same formation (e.g., Rovey and Cherkauer, 1995). Although these data could be interpreted as indicating an underlying scale dependence in K , Butler and Healey (1995b) argue that the slug-test K is artificially low as a result of low-permeability well skins. They speculate that the low- K skins are primarily a result of incomplete well development, i.e. a failure to remove drilling-related debris and/or products of bacterial action from the near-well portions of the formation. Since slug tests are extremely sensitive to near-well conditions (e.g., Moench and Hsieh, 1985), incomplete well development can result in slug-test estimates being more reflective of the altered (lower permeability), near-well material than the formation

itself.

Although theoretical models for slug tests in wells with skins exist (e.g., Ramey et al., 1975; Moench and Hsieh, 1985; Hyder et al., 1994), these models are of quite limited use in practice because of the nonuniqueness of test responses in the presence of a low-K skin (e.g., Moench and Hsieh, 1985). This nonuniqueness is especially pronounced in wells that are screened over a limited portion of the formation, which is the usual situation in groundwater investigations. Thus, it may be virtually impossible to obtain a reliable estimate of the hydraulic conductivity of the formation from a slug test in a well with a low-K skin under conditions commonly faced in the field.

Since hydraulic-conductivity estimates from slug tests in wells with low-K skins are of little value, it is imperative that the field practitioner recognize when a low-K skin is present. In this presentation, several approaches for the field detection of low-K well skins are presented. Particular emphasis is placed on a new approach based on repeat slug tests in which the effective casing radius is changed between tests.

LOW-K SKINS - THE REALITY

Commonly used methods for the analysis of slug-test data often employ the unrealistic assumption that the near-well portions of the formation have been well developed along the entire length of the gravel pack (Figure 1A). Regardless of which drilling technology is employed, however, a considerable amount of drilling debris will be deposited in the near-well portions of the formation. Given standard well installation and development procedures, it may be very difficult to remove this debris from portions of the formation that are opposite the gravel pack, but either above or below the screened interval. In reality, the near-well portions of the formation will invariably only be developed immediately adjacent to the screen, and even there the development may just be partially successful. Thus, the best one can hope for are conditions similar to those depicted in Figure 1B. Actual conditions, however, are undoubtedly much closer to Figure 1C or worse, especially when one considers the additional impacts of bacterial action, inappropriate sizing/placement of the gravel pack, vertical variations in formation K, etc. If we are to have any confidence in the parameter estimates obtained from slug tests, we need to be able to recognize the presence of conditions similar to those depicted in Figure 1C.

CLASSIFICATION/RECOGNITION OF LOW-K SKINS

Well skins may be classified with respect to their response to the pressure disturbance initiating a slug test. If a portion of the material that is forming a low-K skin is mobilized by the slug-induced disturbance, the skin is considered to be dynamic in nature. In this case, one should expect to see sizable changes in K estimates between repeat slug tests at a well (e.g., Figure 2, where T_0 is the basic time lag (time at which a normalized head of 0.37 is reached) of Hvorslev (1951)). If flow during the slug test is insufficient to mobilize this material, the skin is considered to be static in nature. In the static case, one should expect a consistent set of K estimates from repeat tests (e.g., Figure 3). The response of a skin may be a function of the amount of flow induced by a slug test. For example, Figure 3 displays data from a series of shut-in slug tests (Neuzil, 1982) that were performed at the same well as in Figure 2, prior to the tests in Figure 2. Although the later tests of Figure 2 revealed the presence of a low-K skin, the very small amount of flow during the shut-in tests was insufficient to mobilize a portion of that skin. Note that regardless of whether a skin is dynamic or static in nature, there often exists a skin-related directional dependence in the response data (e.g., Figure 4).

There are a number of approaches for recognizing low-K skins from slug-test data. These approaches, which can be subdivided into single- and multi-test methods, are briefly described in the following sections.

SINGLE-TEST METHODS

It can be extremely difficult to recognize the presence of a low-K skin from the results of a single slug test. Occasionally, dynamic skin effects may be so dramatic that there is a clear break on the response plot. For example, the break at point A for Test #2 on Figure 2, which is more clearly seen in the log head versus time plot of Figure 5, is a clear indication of a dynamic skin. In most cases, however, dynamic skin effects will be difficult to recognize on the basis of a single test. One can attempt to identify the presence of a low-K skin by comparison of test responses with theoretical models for slug tests in homogeneous formations (e.g., Cooper et al., 1967; Hyder et al., 1994). When a low-K skin is present, one will see a systematic deviation between test responses and the best-fit theoretical model. Figure 6 shows such a deviation for the case of a skin that is on the order of a factor of two less permeable than the formation. As Hyder et al. (1994) explain, however, a similar deviation is produced by slug-induced vertical flow, so there is a considerable degree of nonuniqueness for partially penetrating wells. A final approach would be to attempt to fit the data using existing models for slug tests in wells with low-K skins (e.g., Moench and Hsieh, 1985; Hyder et al., 1994). Again, however, nonuniqueness of test responses makes the approach of limited value. Thus, data from a single slug test are, in general, of very limited use for the identification of low-K skins.

MULTI-TEST METHODS

Butler et al. (1996) recommend a multi-test approach to exploit the dynamic (e.g., Figure 2) and directional-dependent (e.g., Figure 4) character of many low-K skins. At least three slug tests should be performed at each well. In order to allow the directional dependence of test responses to be assessed, one of these tests should be configured so that flow in response to the slug-induced disturbance is opposite the direction of the other tests. The performance of repeat slug tests using H_0 in the range of 0.3 to 3 m is usually sufficient to mobilize a portion of the low-K skin and/or reveal a skin-related directional dependence. If such effects are not seen in a series of repeat slug tests performed in formations of moderate to high conductivity, it has been our experience that theoretical models (e.g., Cooper et al., 1967; Hyder et al., 1994) will provide very reasonable fits to the test data. However, only limited credence should be given to the resulting K estimates because the slug-induced flow may simply be constrained to a few thin, well-developed zones that pass through a relatively static low-K skin (e.g., Fig. 1C).

Additional testing is required for cases where there is concern that the skin is primarily static in nature. A new multi-test approach for assessing the presence of a static skin is described in the following sections.

THE INFLUENCE OF THE DIMENSIONLESS STORAGE PARAMETER (α)

Most field practitioners use the techniques of Hvorslev (1951) or Bouwer and Rice (1976) to analyze response data from slug tests. These methods are based on two major assumptions concerning the slug-induced flow system: 1) there is an effective radius beyond which the slug-induced disturbance has no effect on formation heads, and 2) the influence of specific storage on test responses is essentially negligible. When these approximations are appropriate, a plot of the log of the deviation of head from static conditions versus time will be linear in form. However, Chirlin (1989) shows that the linearity of a log head versus time plot will depend on the value of the dimensionless storage parameter ($\alpha = (2r_w^2 b S_s) / r_c^2$). When α is small, the plots will be linear in form. As α increases, however, the plots will display an increasingly pronounced concave-upward curvature. Note that a significant proportion of vertical flow in response to the slug-induced disturbance (i.e. a test in a partially penetrating well) will serve to suppress the concave-upward curvature with respect to the case of a fully penetrating well.

When a slug test is performed at a well with a low-K skin, almost all of the head drop occurs across the skin; heads in the formation are essentially unaffected by the test (e.g., Faust and Mercer, 1984). In addition, the specific storage of the skin has very little influence on the response data because the thickness of the skin is relatively small. Thus, the two major assumptions of the Hvorslev/Bouwer and Rice methods appear to be more reasonable in the case of a low-K well skin than in the homogeneous case. The result is that plots of log head versus

time from tests in wells with low-K skins will be approximately linear over a very wide range of α values, whereas plots from tests in a homogeneous formation will display increasingly greater concave-upward curvature over the same range. This difference in the dependence of slug-induced responses on α between the homogeneous and low-K skin cases can be exploited to detect the existence of a skin if one can perform repeat slug tests at the same well using different values of α between tests. A description of one approach for changing α is given in the following section.

CHANGING α VIA THE EFFECTIVE CASING RADIUS

Once a well has been emplaced, most of the well-formation parameters are fixed quantities. The exception to this is the effective radius of the casing (r_c), which can be readily changed by using a packer-standpipe arrangement (e.g., Figure 10 and Butler and Healey (1995a)). Because r_c is in the denominator of α , a decrease in r_c will lead to an increase in α . In the configuration of Figure 10, the standpipe is attached to the central flow-through pipe of the packer, which can be opened/closed from the surface using a wireline. In an injection slug test, the standpipe would extend from the packer (located below the static level in the well) to some distance above the expected H_0 . Thus, all water level changes during the test would occur in the smaller-diameter standpipe. Note that decreasing r_c speeds up the duration of the test. The ultimate result of continual decreases in r_c is the shut-in slug test used in formations of very low K (e.g., Neuzil, 1982).

Changing the casing radius (and hence α) between tests is the basis of the multi-test method proposed here. Moench and Hsieh (1985) speculated that performing repeat slug tests with different α might prove useful for estimating skin and formation properties. However, other than a series of tests described by Novakowski (1988) to assess if fracture width changed with depth of investigation, very little work has apparently been done on varying α between slug tests at the same well.

DETECTION OF A STATIC LOW-K SKIN

Equation (1) is the Hvorslev expression (case 8 of Hvorslev (1951)) for the hydraulic conductivity (K_{HV}) estimated from a slug test in a partially penetrating well in an isotropic formation:

$$K_{HV} = \frac{r_c^2 \ln[b/(2r_w) + [1+(b/2r_w)^2]^{0.5}]}{2bT_0} \quad (1)$$

where b and r_w are screen length and radius, respectively.

When a test is repeated with a different casing radius, only r_c and T_0 change in (1). Thus, the ratio of the right hand side of equation (1) for the second test (assume with smaller r_c) over that for the first test can be written as

$$\frac{(r_c^2/T_0)_2}{(r_c^2/T_0)_1} \quad (2)$$

where 1 and 2 designate the tests with the original and smaller casing radii, respectively.

The method proposed here is based on a plot of equation (2) (henceforth designated as the Hvorslev ratio) versus the ratio of the squared casing radii (r_{c1}^2/r_{c2}^2). In order to assess the viability of the approach, a series of numerical experiments were run using a semianalytical solution for slug tests in partially penetrating wells (Liu and Butler, 1995). Figure 7 is a plot of equation (2) versus the r_c ratio for the case of a fully penetrating well ($\alpha=4.2e-4$ for test 1, radius of skin twice that of screen). As shown in the figure, the difference between the Hvorslev-

ratio curves will increase with the magnitude of the change in r_c and that of the skin-formation contrast. Figure 7 indicates that it should be possible to identify a low-K skin that is an order of magnitude or more less conductive than the formation when the well is screened across the entire formation. Identification of smaller contrasts may be possible if large changes in r_c are employed.

Figure 8 displays results for a partially penetrating well (aspect ratio (b/r_w) of 17.5). The difference between Hvorslev-ratio curves is clearly much smaller when there is a significant component of vertical flow. Thus, a relatively large change in r_c must be effected for the method to be viable in wells of small aspect ratios. This need for a relatively large change in r_c restricts the method to formations of moderate to low K. Even when the change in r_c is large, however, it will be difficult to identify a skin-formation contrast of less than an order of magnitude. Note that Figure 8 is based on an initial α of $4.2e-4$. The dependence of the Hvorslev ratio on r_c is a function of α . Figure 9 displays results for an initial α of $4.2e-2$, a value that might be found in low-K, clay-rich formations. The approach is clearly much more effective in this situation. Note that the pronounced rise seen in the skin curves above a r_c ratio of 50 (i.e. at very large α) occurs because the effective radius of the slug test has become smaller than the outer radius of the skin. This dependence of the effective radius of a slug test on α is the feature that Novakowski (1988) was trying to exploit in the tests he describes.

INITIAL FIELD EVALUATION

An initial field evaluation of this new approach has begun at two Kansas Geological Survey monitoring sites (Stafford County site 18 and the Trego County monitoring site). Figures 2 and 3 display the results of tests that were performed with two different r_c at the same 5" well at the Stafford site. Unfortunately, fairly dramatic dynamic skin effects (e.g., Figure 2) were seen in tests at both sites when r_c greater than 0.5" were employed. These effects made it impossible to rigorously evaluate the potential of the approach. Further testing of the methodology is planned using a range of small r_c in an attempt to minimize the influence of dynamic skin effects on the methodology evaluation.

CONCLUSIONS

Undoubtedly, the primary source of large errors in parameter estimates obtained from slug tests is the failure to recognize the existence of a low-permeability (low-K) well skin. A program of slug tests should therefore be designed to assess whether a low-K skin exists at the test well. It is extremely difficult to recognize the presence of a low-K skin from the results of a single slug test. However, a program of multiple slug tests at a single well will often reveal the existence of a skin. The multi-test approach described by Butler et al. (1996) exploits the dynamic and directional-dependent character of many low-K skins. Static skins, however, will often not be recognized using this approach. A new method for the identification of static skins is proposed here. This approach, which exploits some basic features of the physics of slug-induced flow in the presence of a low-K skin, involves the performance of repeat slug tests in which the effective casing radius is changed between tests. A simple plotting method derived from the Hvorslev technique is employed to assess if a skin exists at the test well. Numerical experiments indicate that this new approach holds considerable promise in formations of moderate to low K. A field evaluation of the method is currently underway.

ACKNOWLEDGEMENT

This research was supported in part by the U.S. Geological Survey (USGS), Department of the Interior, under USGS award number 14-08-0001-G2093. The views and conclusions contained in this document are those of the authors and should not be interpreted as necessarily representing the official policies, either expressed or implied, of the U.S. Government.

REFERENCES

- Bouwer, H., and R. C. Rice, 1976, A slug test for determining hydraulic conductivity of unconfined aquifers with completely or partially penetrating wells, *Water Resour. Res.*, v. 12, no. 3, pp. 423-428.
- Butler, J.J., Jr., and J.M. Healey, 1995a, Analysis of 1994-95 hydraulic tests at Trego County monitoring site, Kansas Geological Survey Open-File Rept. 95-66, 30 pp.
- Butler, J.J., Jr., and J.M. Healey, 1995b, Relationship between pumping-test and slug-test parameters: Scale effect or artifact? (abstract), *EOS*, v. 76, no. 46, p. F192.
- Butler, J.J., Jr., C.D. McElwee, and W.Z. Liu, 1996, Improving the quality of parameter estimates obtained from slug tests, *Ground Water*, v. 34, no. 3, pp. 480-490.
- Chirlin, G. R., 1989, A critique of the Hvorslev method for slug test analysis: The fully penetrating well, *Ground Water Monitoring Review*, v. 9, no. 2, pp. 130-138.
- Chirlin, G. R., 1990, The slug test: the first four decades, *Ground Water Management*, v. 1, pp. 365-381.
- Cooper, H.H., J.D. Bredehoeft, and I.S. Papadopoulos, 1967, Response of a finite-diameter well to an instantaneous charge of water, *Water Resour. Res.*, v. 3, no. 1, pp. 263-269.
- Faust, C.R., and J.W. Mercer, 1984, Evaluation of slug tests in wells containing a finite-thickness skin, *Water Resour. Res.*, v. 20, no. 4, pp. 504-506.
- Hvorslev, M.J., 1951, Time lag and soil permeability in ground-water observations, Bull no. 36., *Waterways Exper. Sta., Corps of Engrs., U.S. Army*, 50 p.
- Hyder, Z., J.J. Butler, Jr., C.D. McElwee, and W.Z. Liu, 1994, Slug tests in partially penetrating wells, *Water Resour. Res.*, v. 30, no. 11, pp. 2945-2957.
- Liu, W.Z., and J.J. Butler, Jr., 1995, The KGS Model for slug tests in partially penetrating wells (v. 3.0), Kansas Geological Survey Computer Series Rept. 95-1.
- Moench, A.F. and P.A. Hsieh, 1985, Analysis of slug test data in a well with finite-thickness skin, In: *Memoirs of the 17th Int. Cong. on the Hydrogeology of Rocks of Low Permeability*, v. 17, pp. 17-29.
- Neuzil, C.E., 1982, On conducting the modified "slug" test in tight formations, *Water Resour. Res.*, v. 18, no. 2, pp. 439-441.
- Novakowski, K.S., 1988, Comparison of fracture aperture widths determined from hydraulic measurements and tracer experiments, *Proc. of the Fourth Canadian/American Conf. on Hydrogeology*.
- Ramey, H.J., Jr., R.G. Agarwal, and I. Martin, 1975, Analysis of "slug test" or DST flow period data, *Jour. Can. Pet. Technol.*, v. 14, pp. 53-67.
- Rovey, C.W., II, and D.S. Cherkauer, 1995, Scale dependency of hydraulic conductivity measurements, *Ground Water*, v. 33, no. 5, pp. 769-780.

FIGURE 1

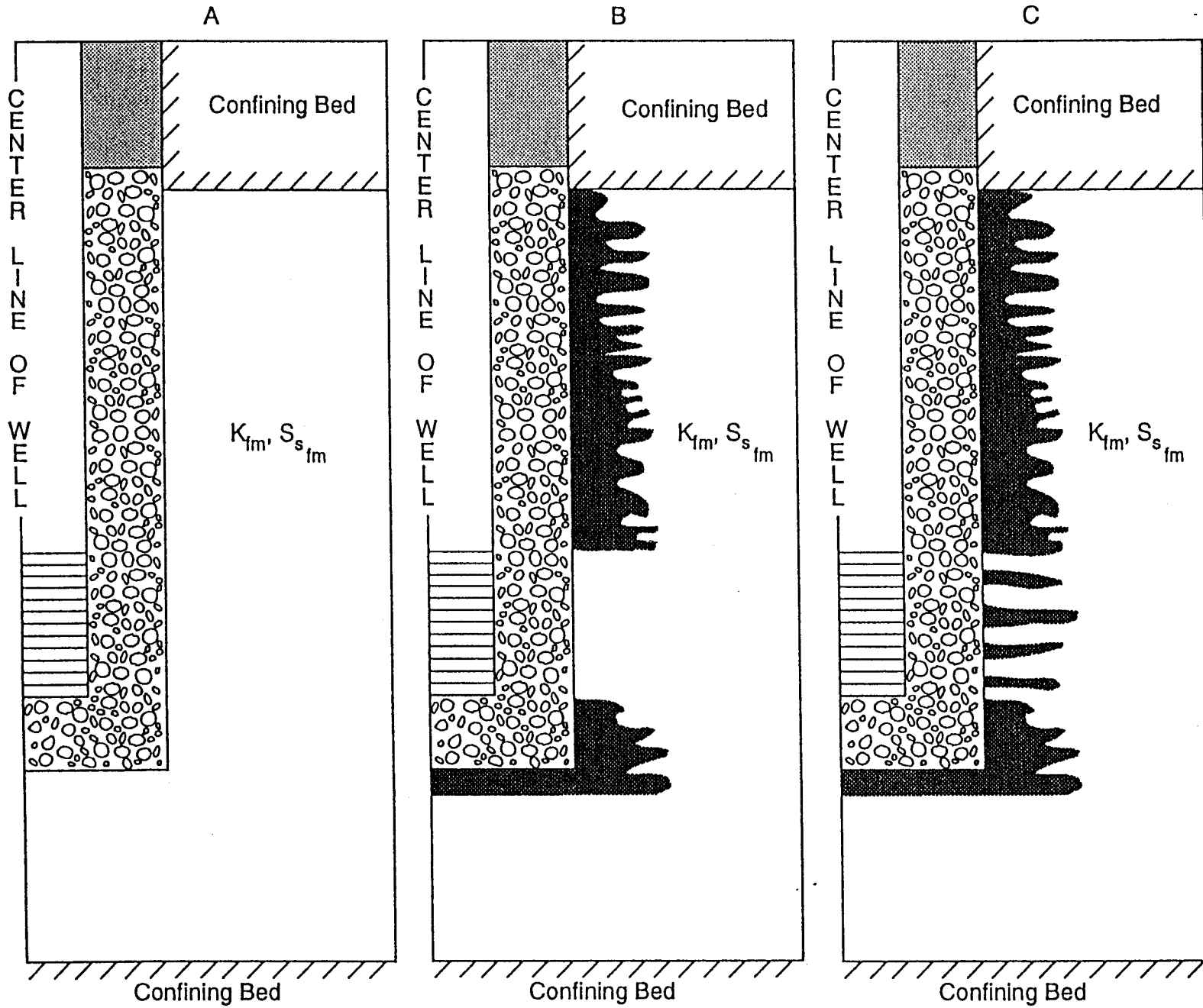

drilling debris grout gravel pack screened interval

FIGURE 2
Stafford County Site 18
9/11/95 Tests

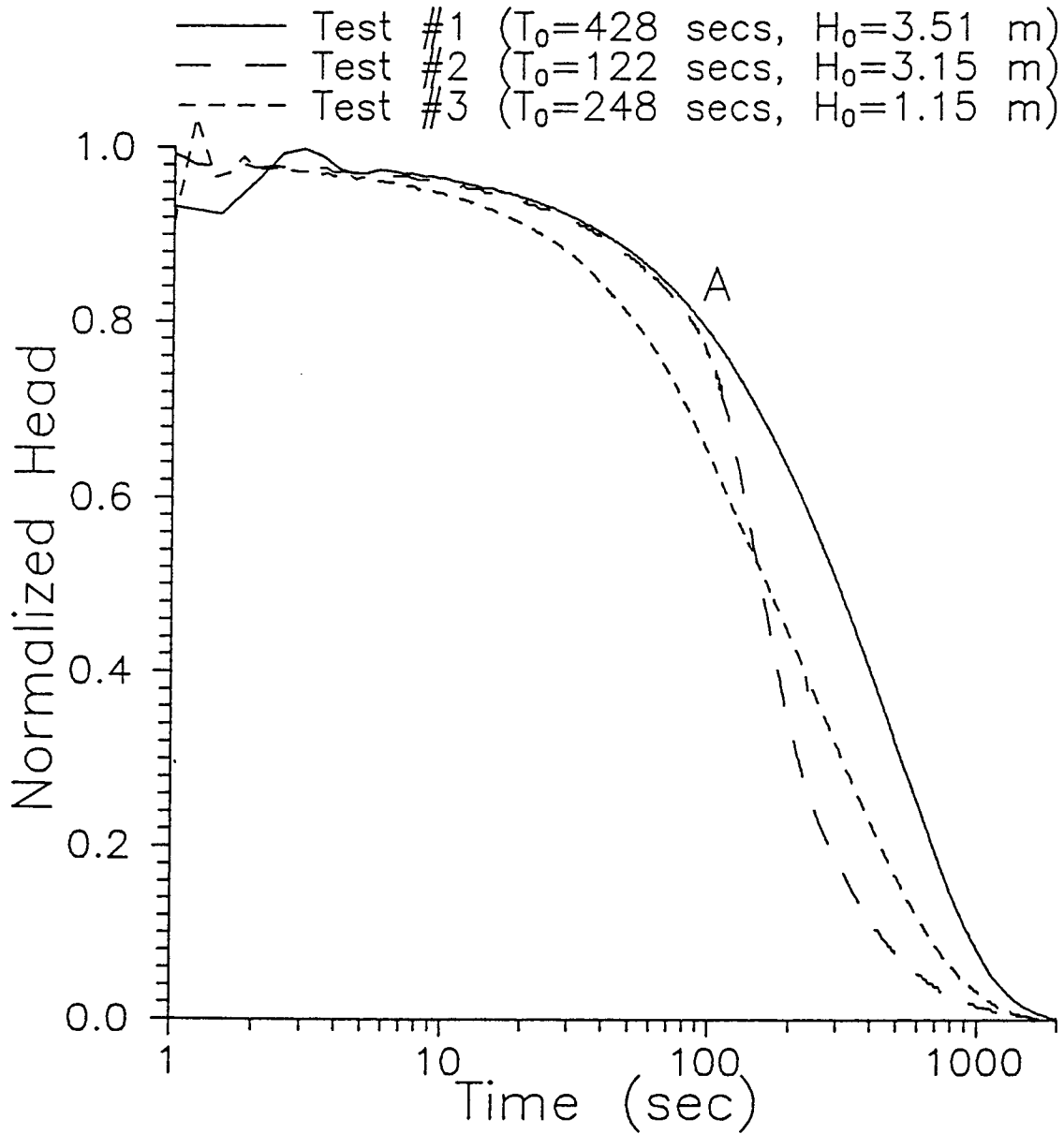

FIGURE 3
Stafford County Site 18
11/17/94 Tests

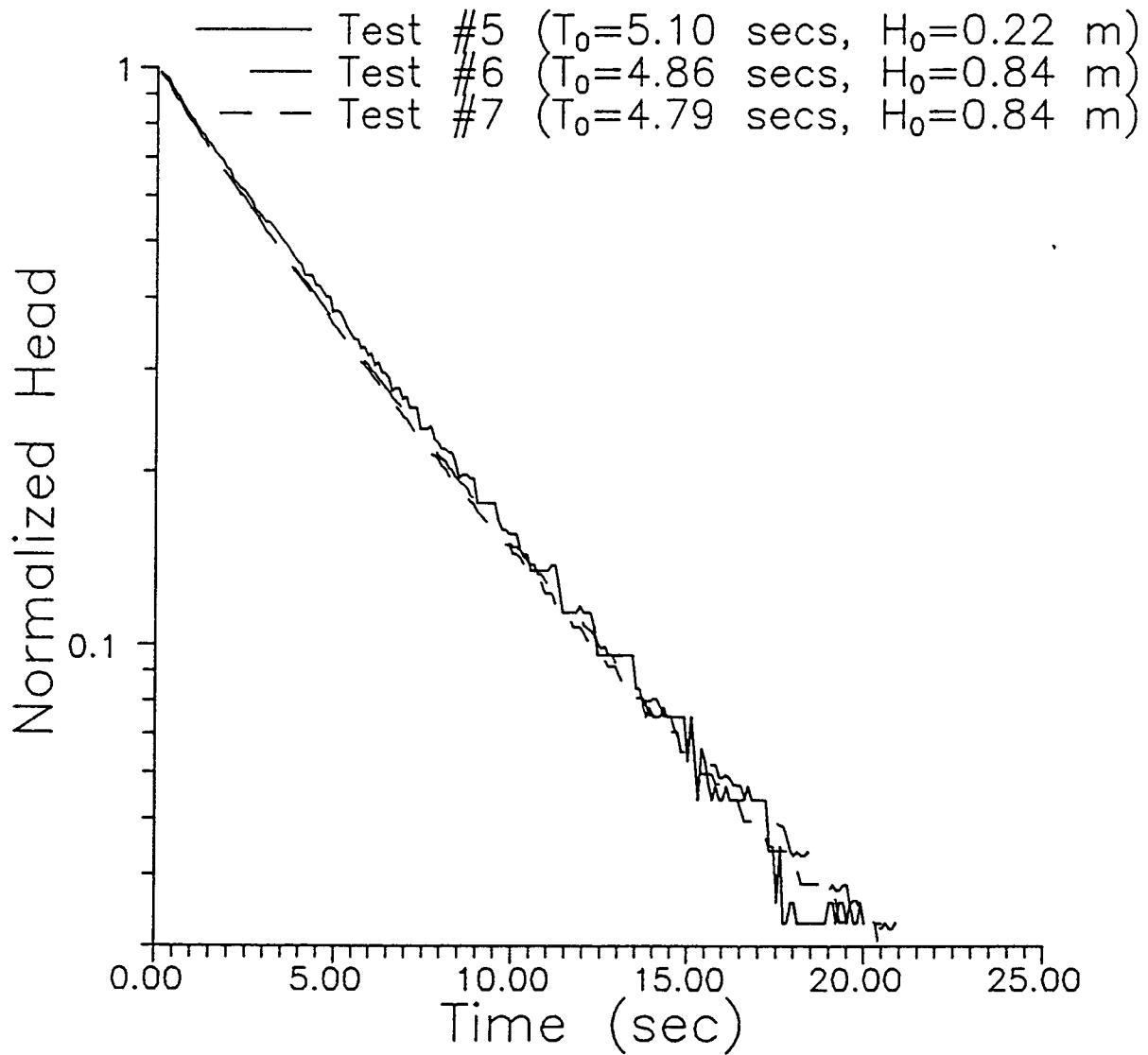

FIGURE 4
Trego County Site, 11/16/95 Tests

— #2a- $T_0=2112$ s, $H_0= 1.82$ m
- - - #2b- $T_0=41.4$ s, $H_0= -1.79$ m

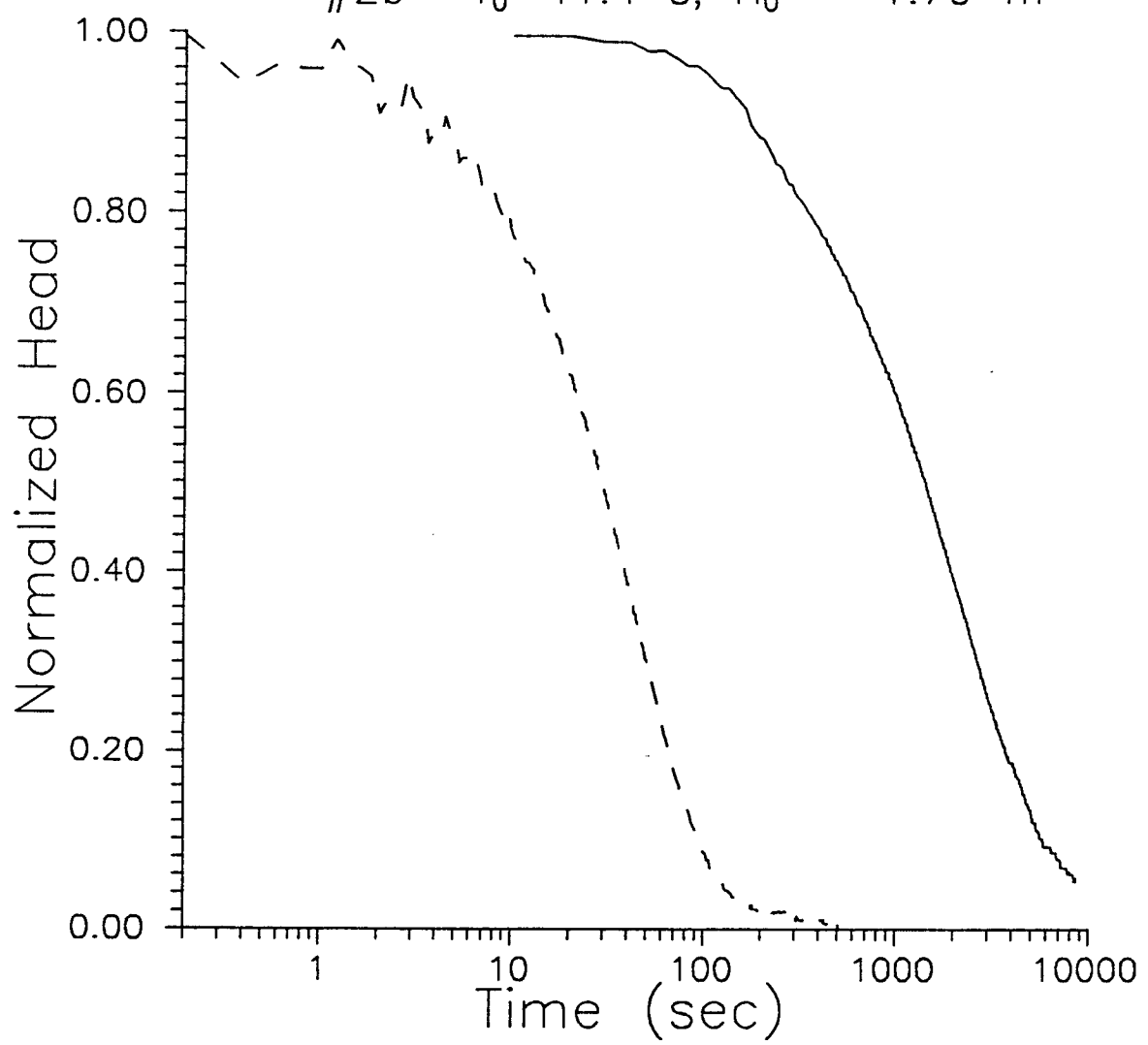

FIGURE 5
Stafford County Site 18
9/11/95 Test #2

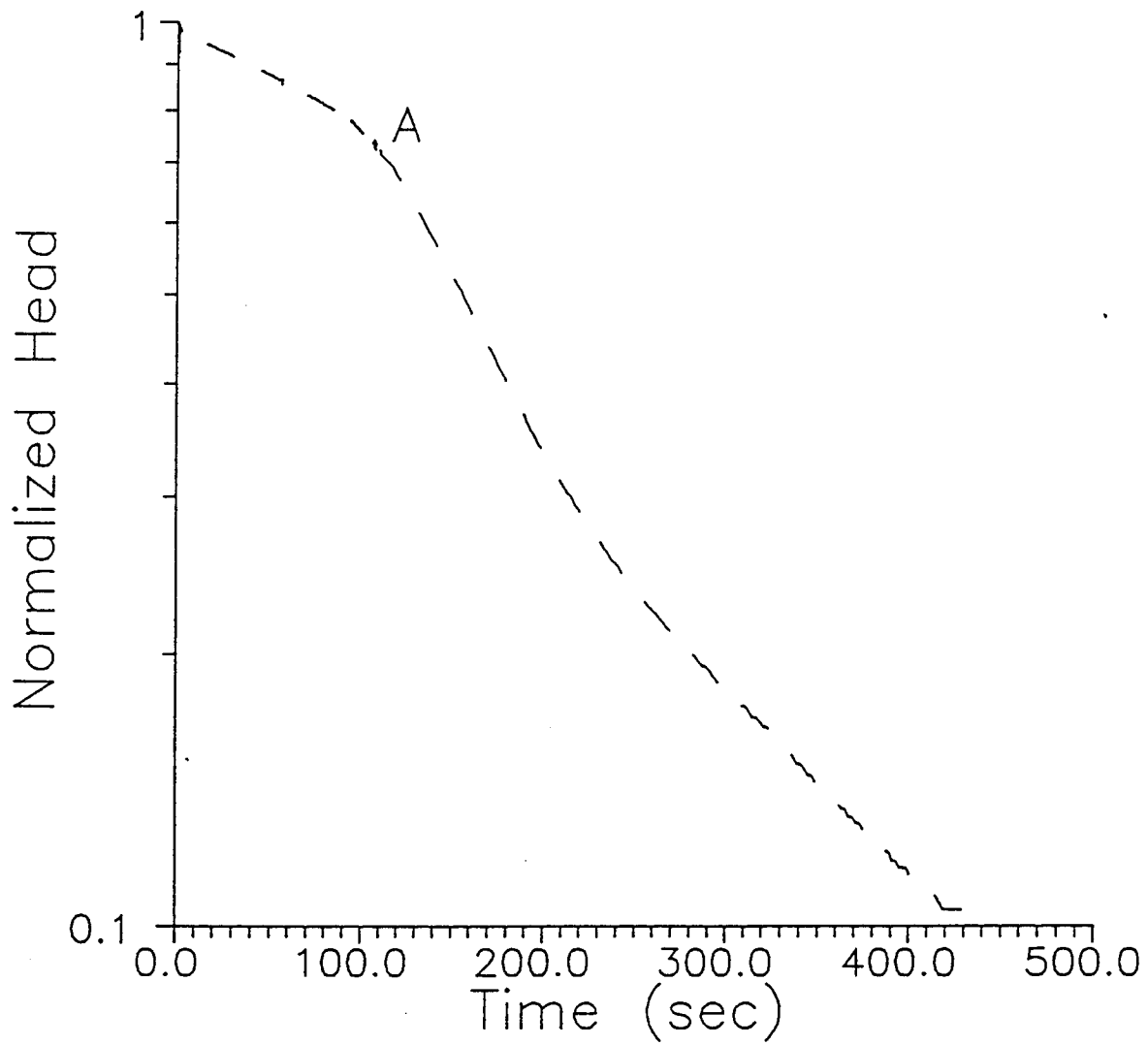

FIGURE 6
Lincoln County Site, Well Ln-3
6/26/91 Test #11

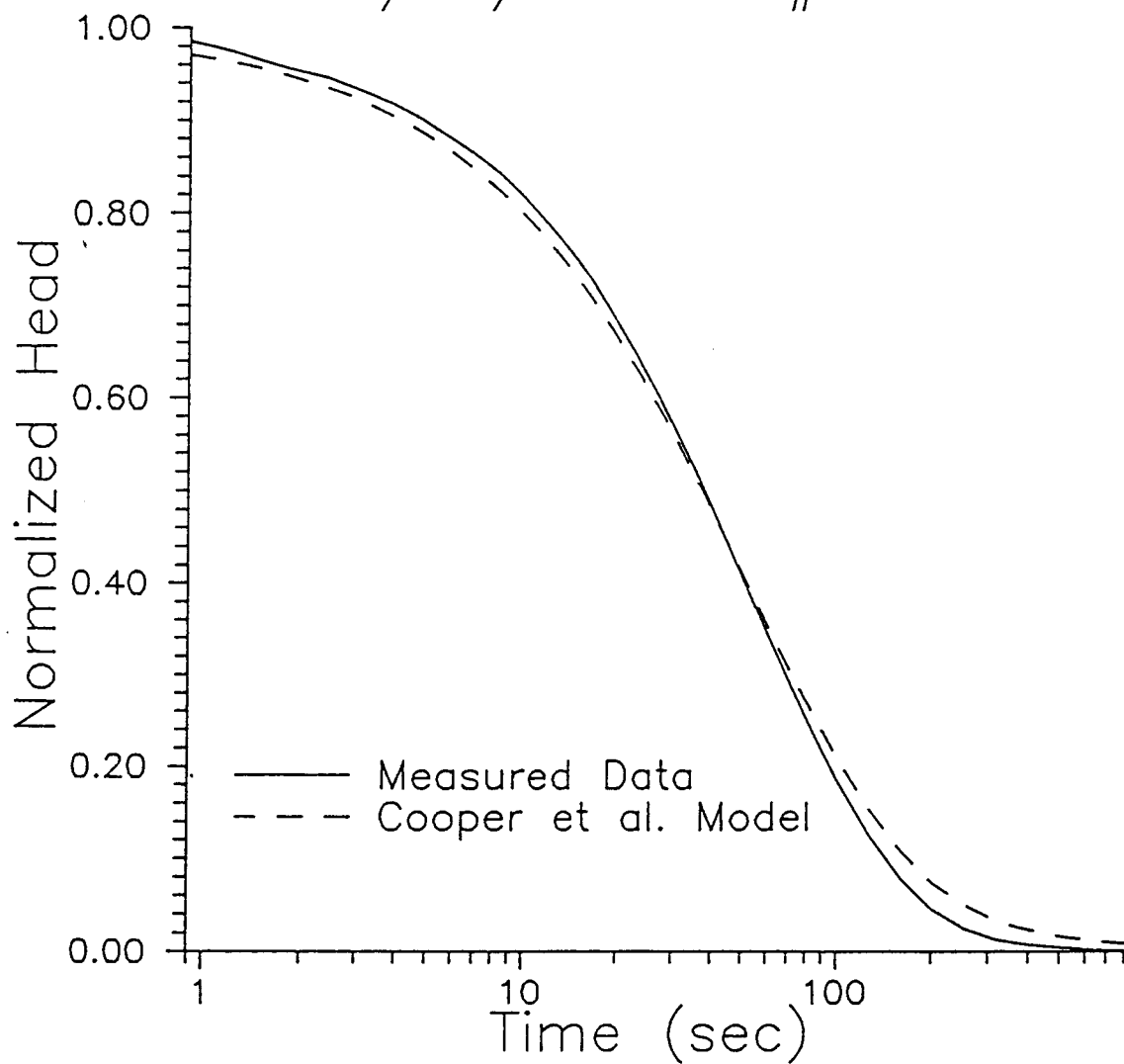

FIGURE 7
Fully Penetrating Well
Initial $\alpha=4.2e-4$

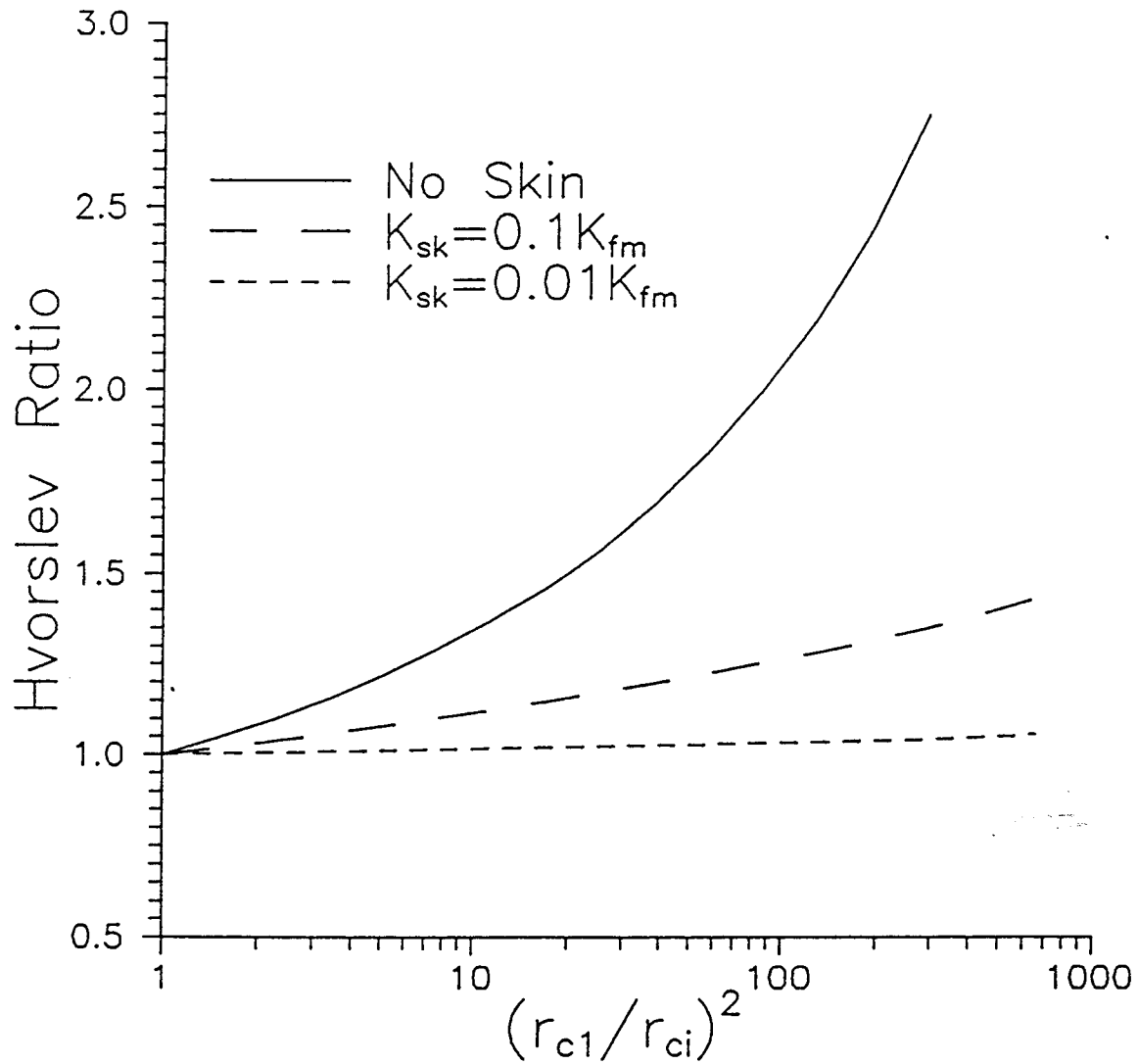

FIGURE 8
Partially Penetrating Well
Initial $\alpha=4.2e-4$

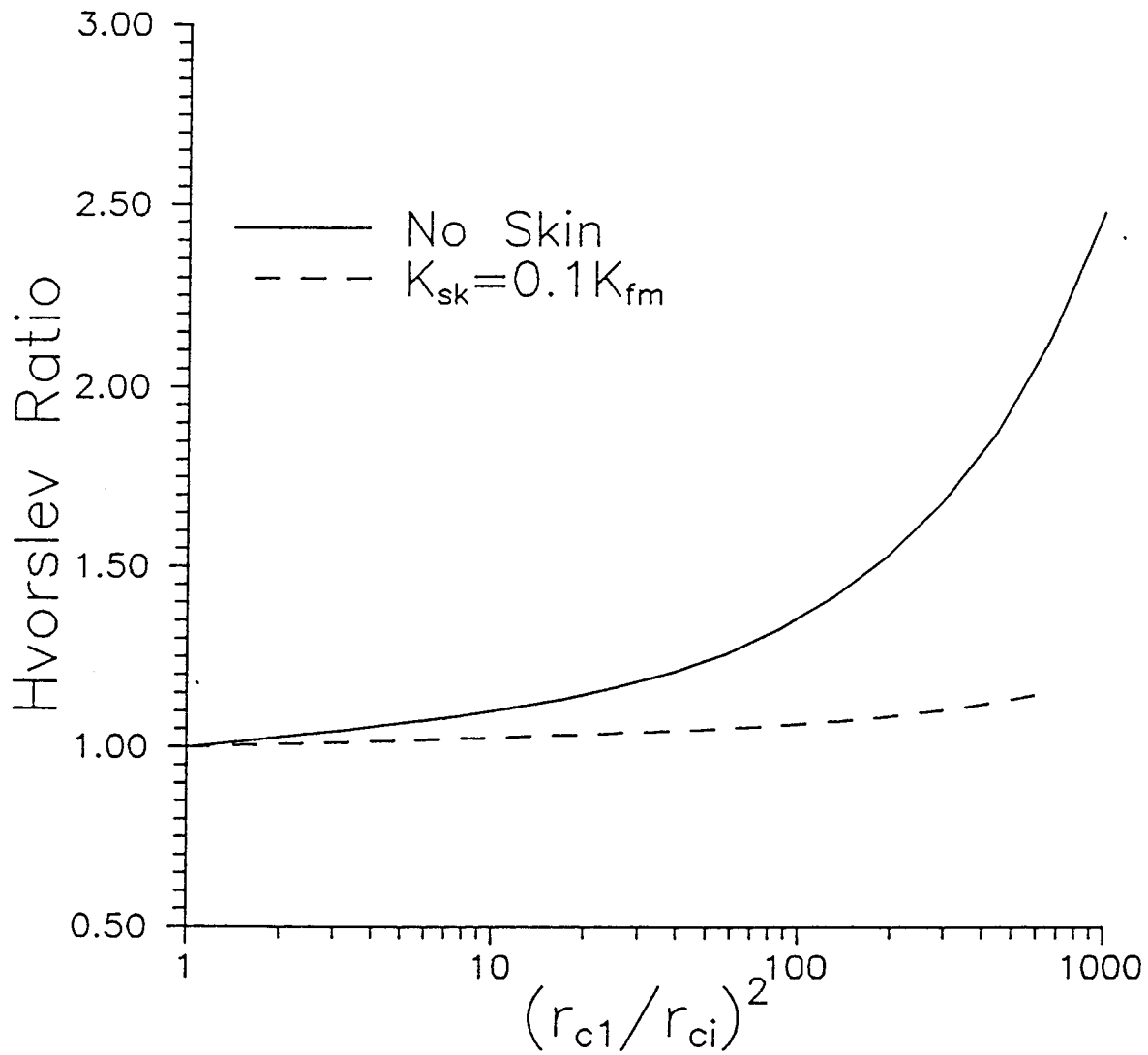

FIGURE 9
Partially Penetrating Well
Initial $\alpha=4.2e-2$

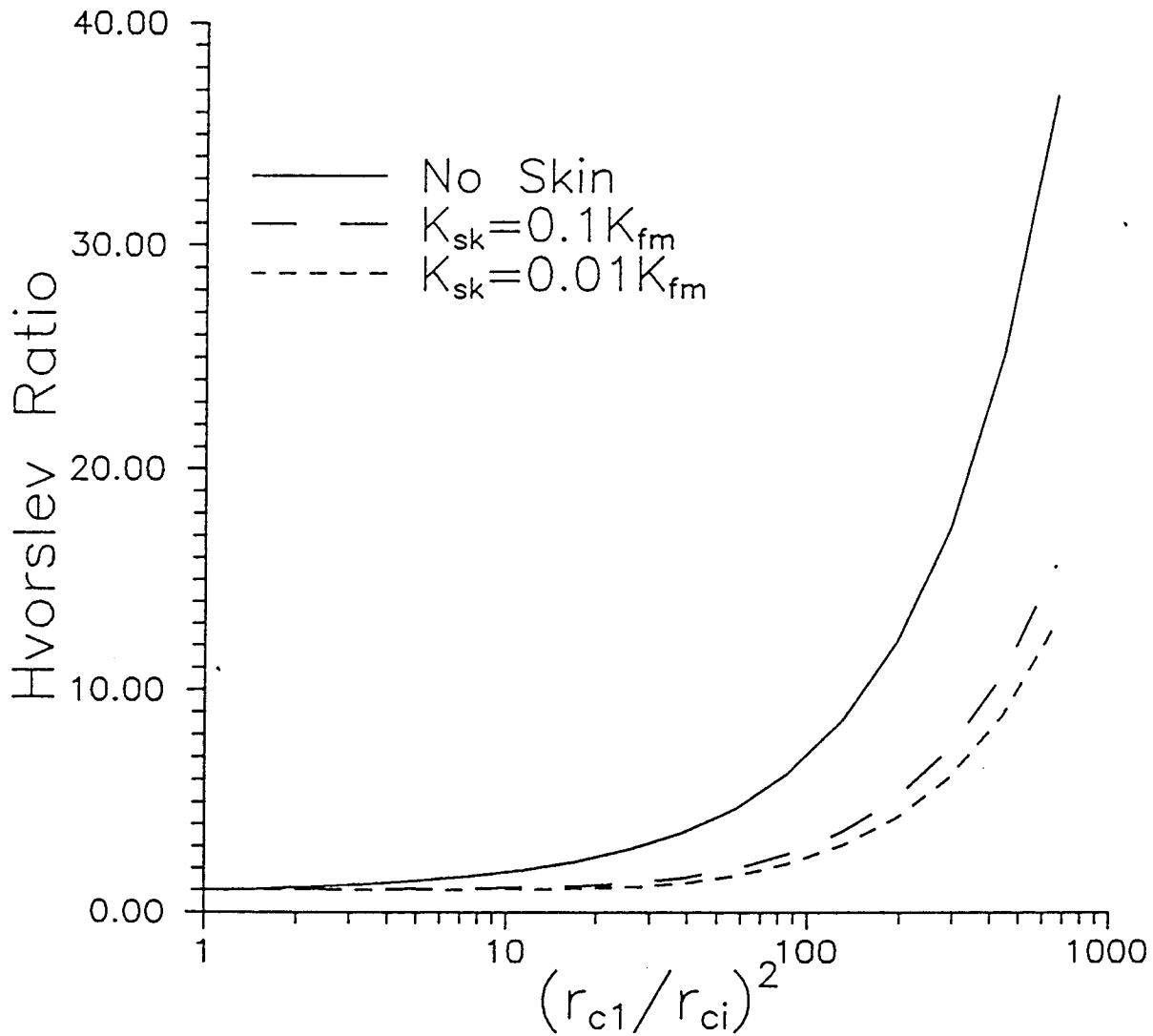
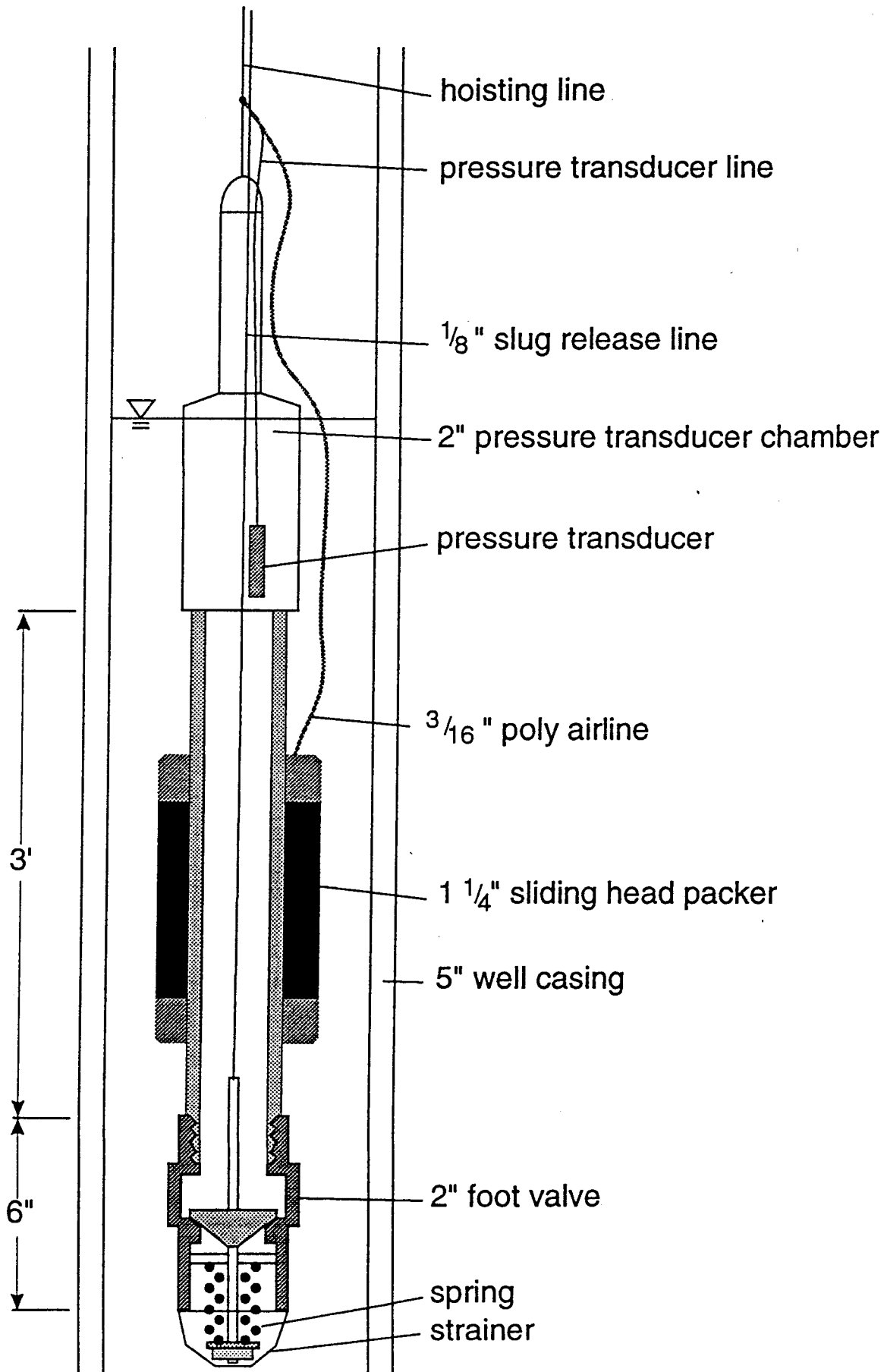

FIGURE 10



not to scale