

HALLIBURTON

SPECTRAL DENSITY DUAL SPACED NEUTRON LOG

COMPANY	SANDRIDGE ENERGY		
WELL	FLINN A 3306 1-11		
FIELD/BLOCK	STOHRVILLE		
COUNTY	HARPER		
STATE	KANSAS		
COMPANY	SANDRIDGE ENERGY	API No.	15-077-21951-00-00
WELL	FLINN A 3306 1-11	Location	(SHL) 660 FSL & 900 FEL
FIELD/BLOCK	STOHRVILLE		
COUNTY	HARPER		
STATE	KANSAS		
Sect.	11	Twp.	33S
Rge.	6W		
Elev.	1311.0 ft		
Log measured from	KB		
Drilling measured from	KB		
			10.0 ft above perm. Datum
			G.L.
			1321.0 ft
			1320.0 ft
			1311.0 ft

Date	17-Jul-13	Run No.	ONE
Depth - Driller	4800.00 ft	Depth - Logger	4802.0 ft
Bottom - Logged Interval	4719.0 ft	Top - Logged Interval	631.0 ft
Casing - Driller	8.625 in	Casing - Logger	631.0 ft
Bit Size	7.875 in	Type Fluid in Hole	WATER BASED MUD
Density	9.2 ppg	Viscosity	41.00 s/qt
PH	10.40 pH	Fluid Loss	4.8 cphm
Source of Sample	MUD PIT	Rm @ Meas. Temperature	0.050 ohmm @ 75.00 degF
Rmf @ Meas. Temperature	0.05 ohmm @ 75.00 degF	Rmc @ Meas. Temperature	0.050 ohmm @ 75.00 degF
Source Rmf	Rmc	MEASURED	MEASURED
Rm @ BHT	0.03 ohmm @ 147.0 degF	Time Since Circulation	7.0 hr
Time on Bottom	17-Jul-13 20:56	Max. Rec. Temperature	147.0 degF @ 4802.0 ft
Equipment	11230668	Location	LIBERAL
Recorded By	J. BOLLOW	Witnessed By	L. SOLIS

Fold here

Service Ticket No.: 900595061 API Serial No.: 15-077-21951-00-00 PGM Version: WL INSITE R3.8.4 (Build 5)

CHANGE IN MUD TYPE OR ADDITIONAL SAMPLE				RESISTIVITY SCALE CHANGES			
Date	Sample No.			Type Log	Depth	Scale Up Hole	Scale Down Hole
Depth-Driller							
Type Fluid in Hole							
Density	Viscosity						
Ph	Fluid Loss						
Source of Sample				RESISTIVITY EQUIPMENT DATA			
Rm @ Meas. Temp	@		@	Run No.	Tool Type & No.	Pad Type	Tool Pos.
Rmf @ Meas. Temp.	@		@				
Rmc @ Meas. Temp.	@		@				
Source Rmf	Rmc						
Rm @ BHT	@		@				
Rmf @ BHT	@		@				
Rmc @ BHT	@		@				

EQUIPMENT DATA

GAMMA		ACOUSTIC		DENSITY		NEUTRON	
Run No.	ONE	Run No.		Run No.	ONE	Run No.	ONE
Serial No.	10811258	Serial No.		Serial No.	10673790	Serial No.	10755066
Model No.	GTET	Model No.		Model No.	SDLT-I	Model No.	DSNT-I
Diameter	3.625"	No. of Cent.		Diameter	4.5"	Diameter	3.625"
Detector Model No.	T-102	Spacing		Log Type	GAM-GAM	Log Type	NEU-NEU
Type	SCINT			Source Type	CS137	Source Type	AM241BE
Length	8'	LSA [Y/N]		Serial No.	5073GW	Serial No.	DSN-436
Distance to Source	18'	FWDA [Y/N]		Strength	1.5 CI	Strength	15 CI

LOGGING DATA

GENERAL				GAMMA		ACOUSTIC		DENSITY			NEUTRON			
Run No.	Depth		Speed	Scale		Scale		Matrix	Scale		Matrix	Scale		Matrix
	From	To	ft/min	L	R	L	R		L	R		L	R	
ONE	4802	631	REC						30	-10	2.71	30	-10	LIME

DIRECTIONAL INFORMATION

Maximum Deviation @ KOP @

Remarks: ANNULAR HOLE VOLUME CALCULATED FOR 5.5-INCH CASING

CHLORIDES REPORTED AT 11,800 MG/L

GTET-CSNG-DSNT-SDLT-IDT-ICT-WAVE-ACRT RUN IN COMBATION

TODAY'S CREW: B. TERRELL & V. JAIME

THANK YOU FOR CHOOSING HALLIBURTON ENERGY SERVICES LIBERAL, KS. 620-624-8123

HALLIBURTON DOES NOT GUARANTEE THE ACCURACY OF ANY INTERPRETATION OF THE LOG DATA, CONVERSION OF LOG DATA TO PHYSICAL ROCK PARAMETERS OR RECOMMENDATIONS WHICH MAY BE GIVEN BY HALLIBURTON PERSONNEL OR WHICH APPEAR ON THE LOG OR IN ANY OTHER FORM. ANY USER OF SUCH DATA, INTERPRETATIONS, CONVERSIONS, OR RECOMMENDATIONS AGREES THAT HALLIBURTON IS NOT RESPONSIBLE EXCEPT WHERE DUE TO GROSS NEGLIGENCE OR WILLFUL MISCONDUCT, FOR ANY LOSS, DAMAGES, OR EXPENSES RESULTING FROM THE USE THEREOF.

HALLIBURTON

HALLIBURTON

Plot Time: 18-Jul-13 00:57:52
 Plot Range: 620 ft to 4806.83 ft
 Data: FLINN_A_3306\Well Based\CASING\
 Plot File: \\PORO\Poro_IQ_5_MAIN_LIB

5 INCH MAIN LOG

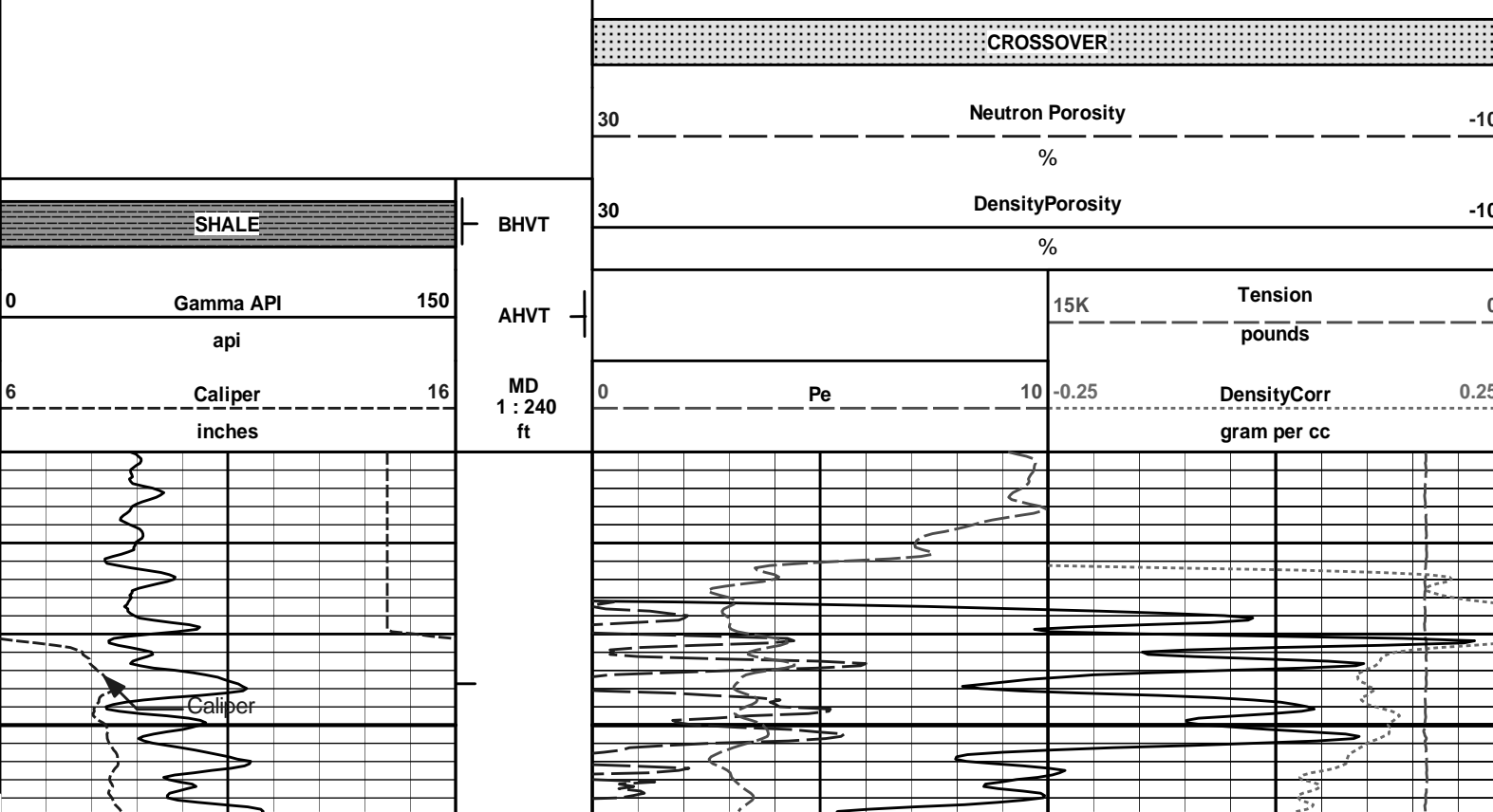

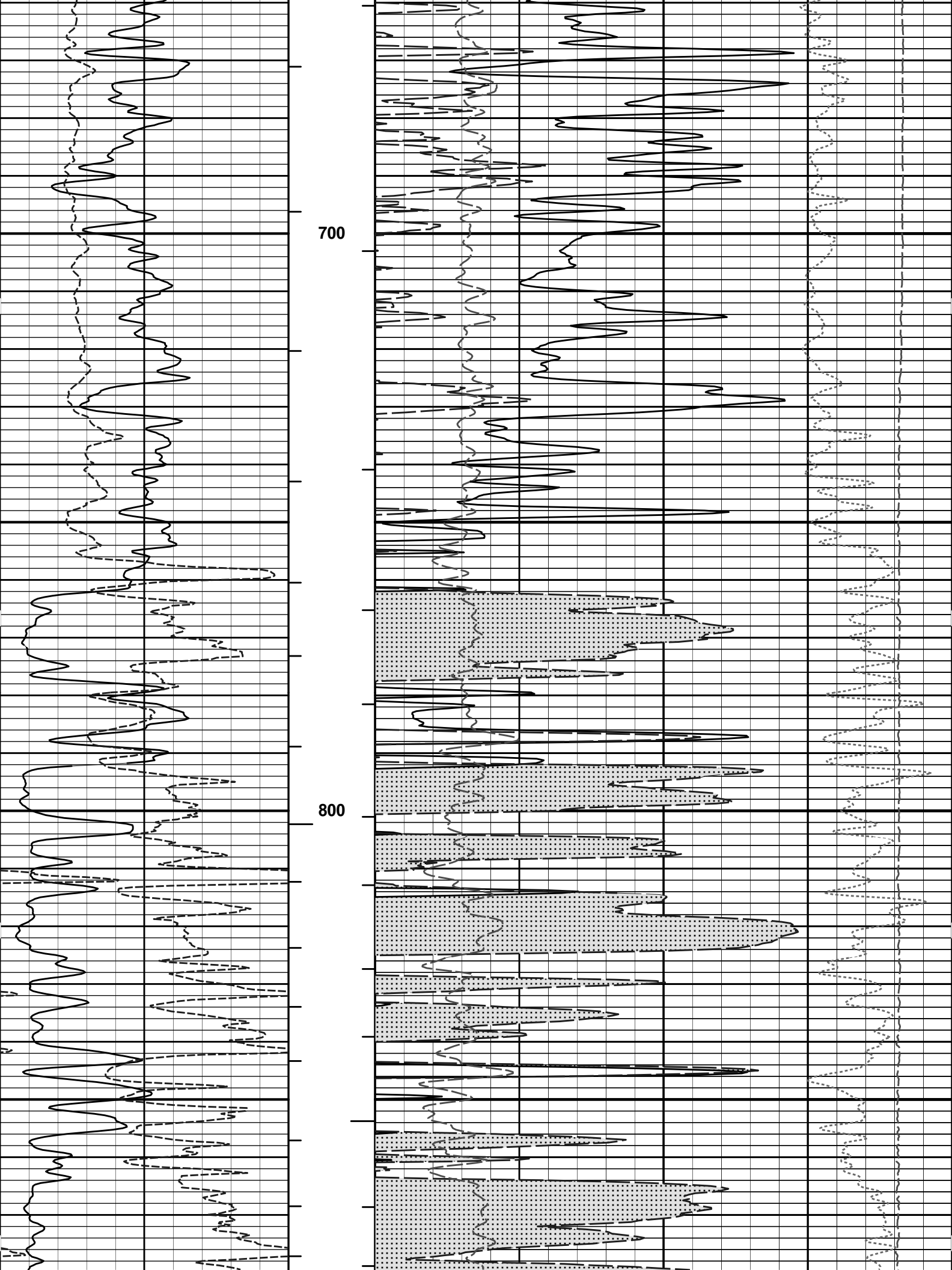

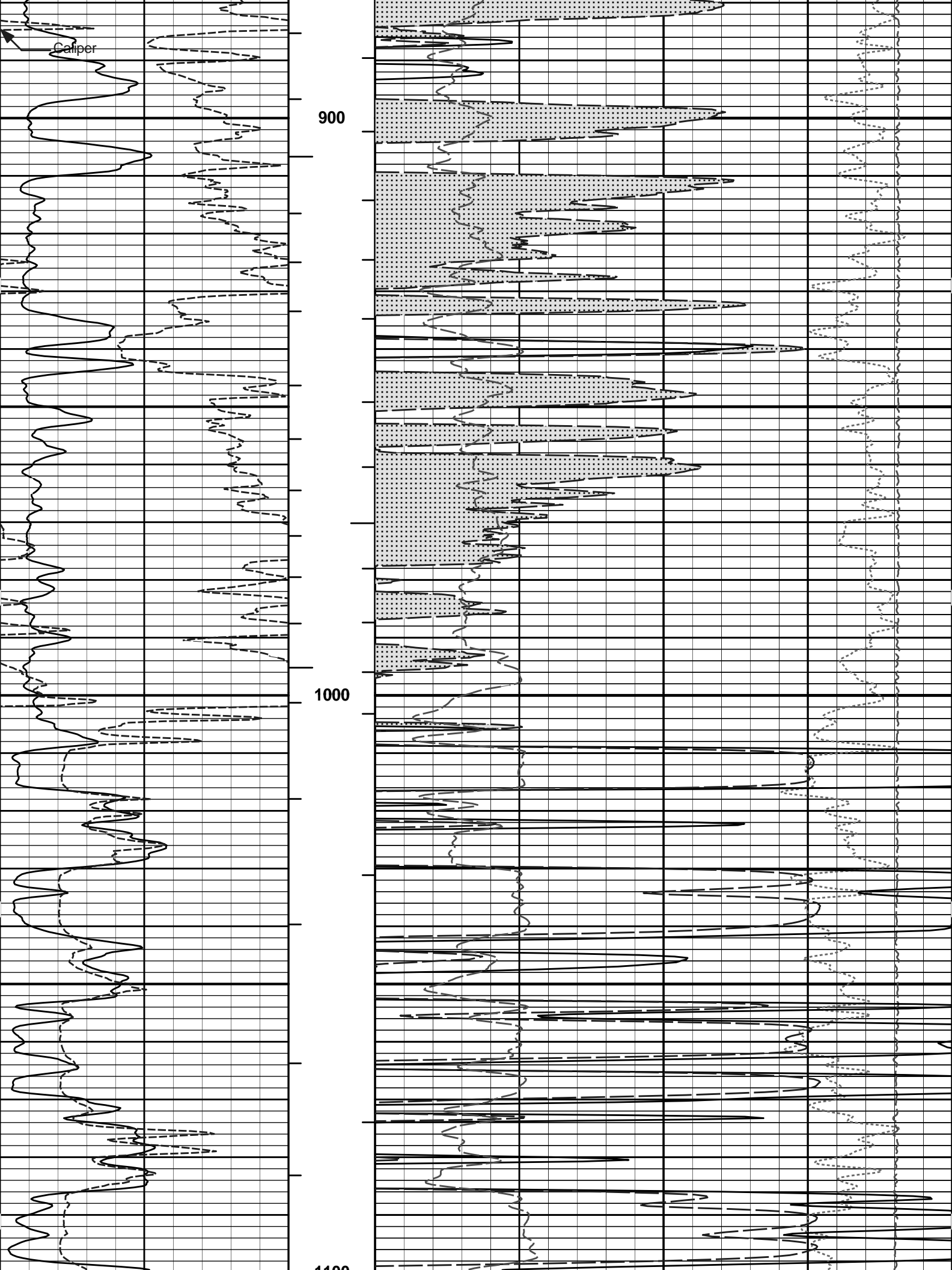

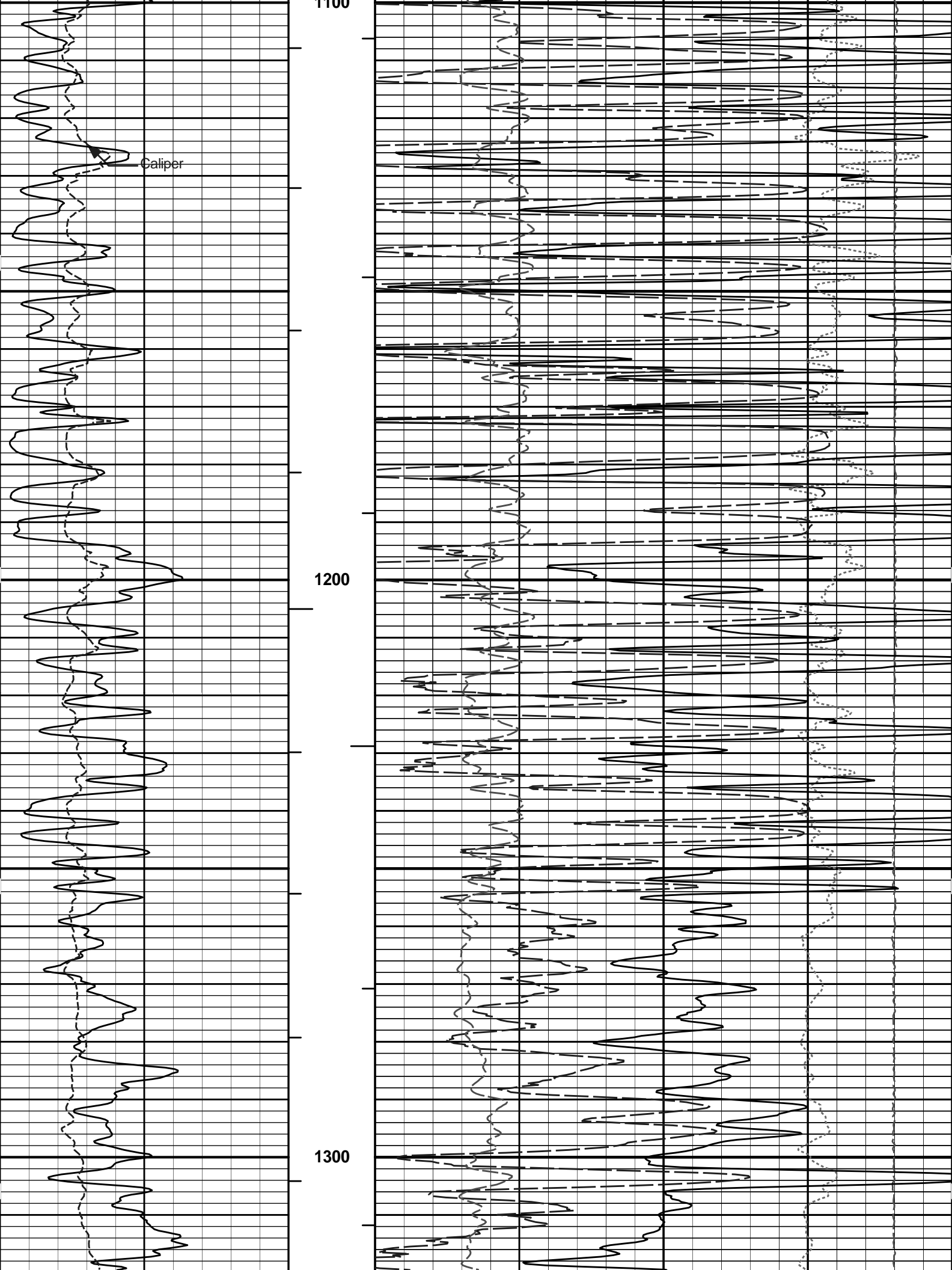

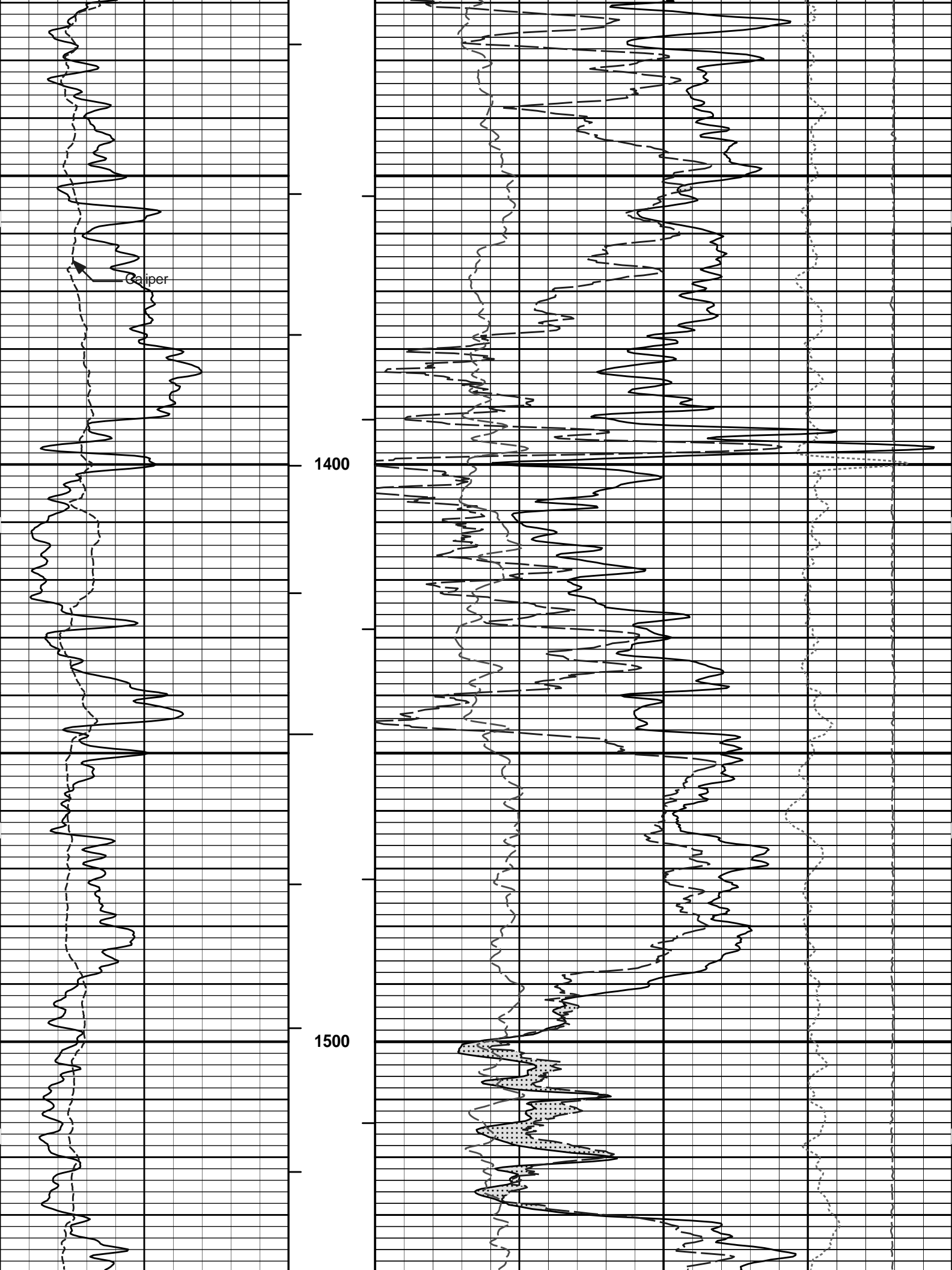

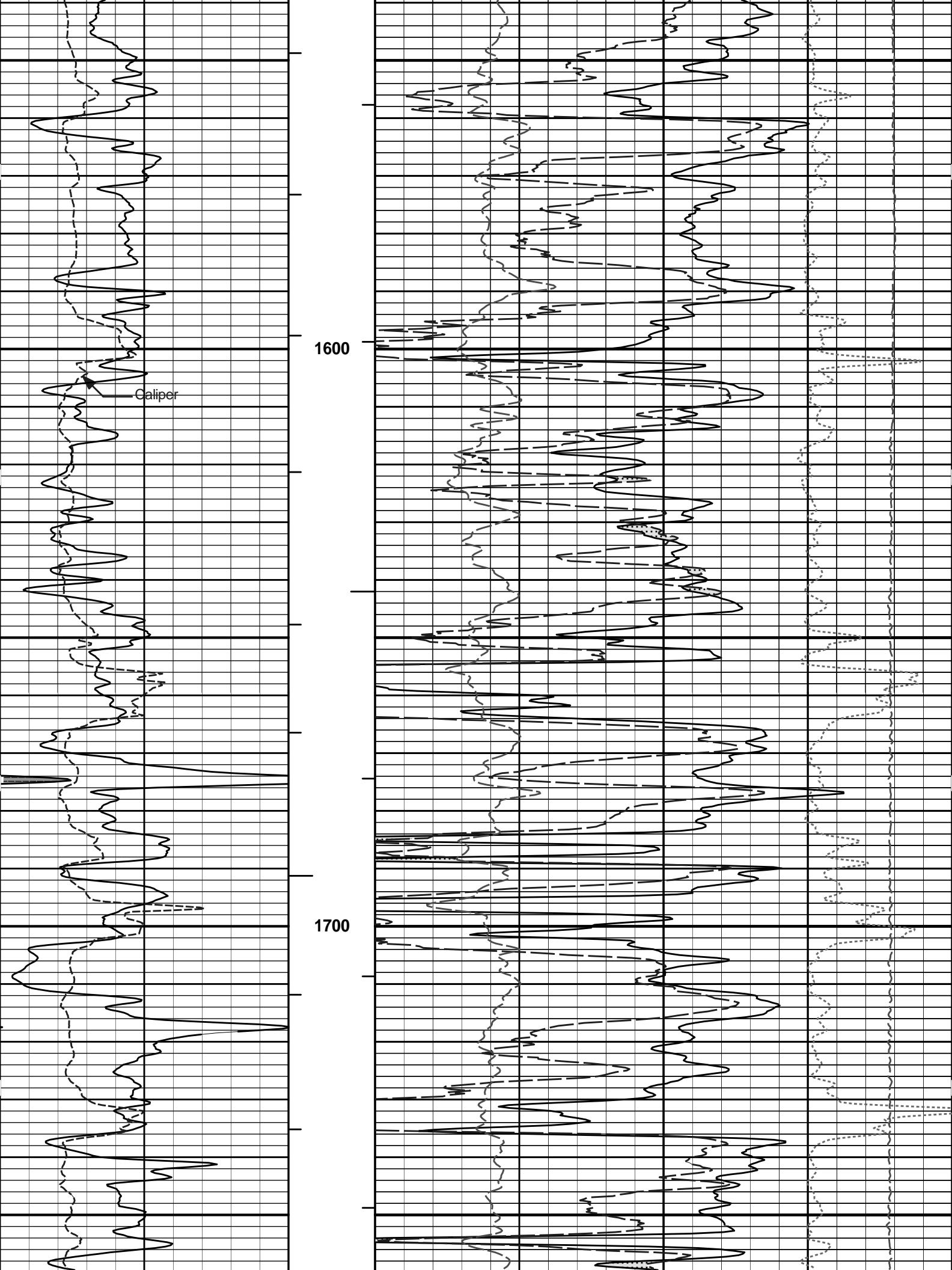

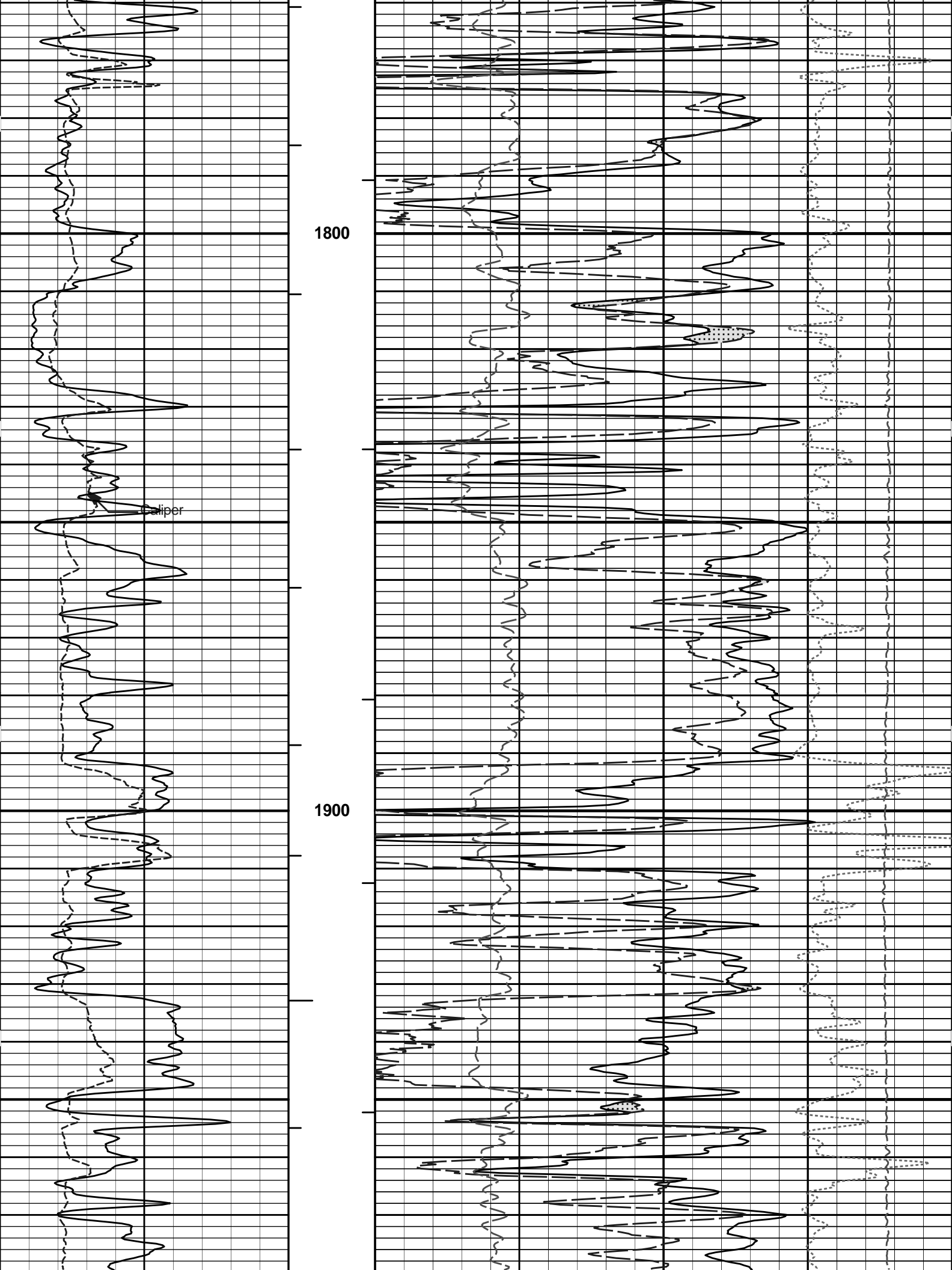

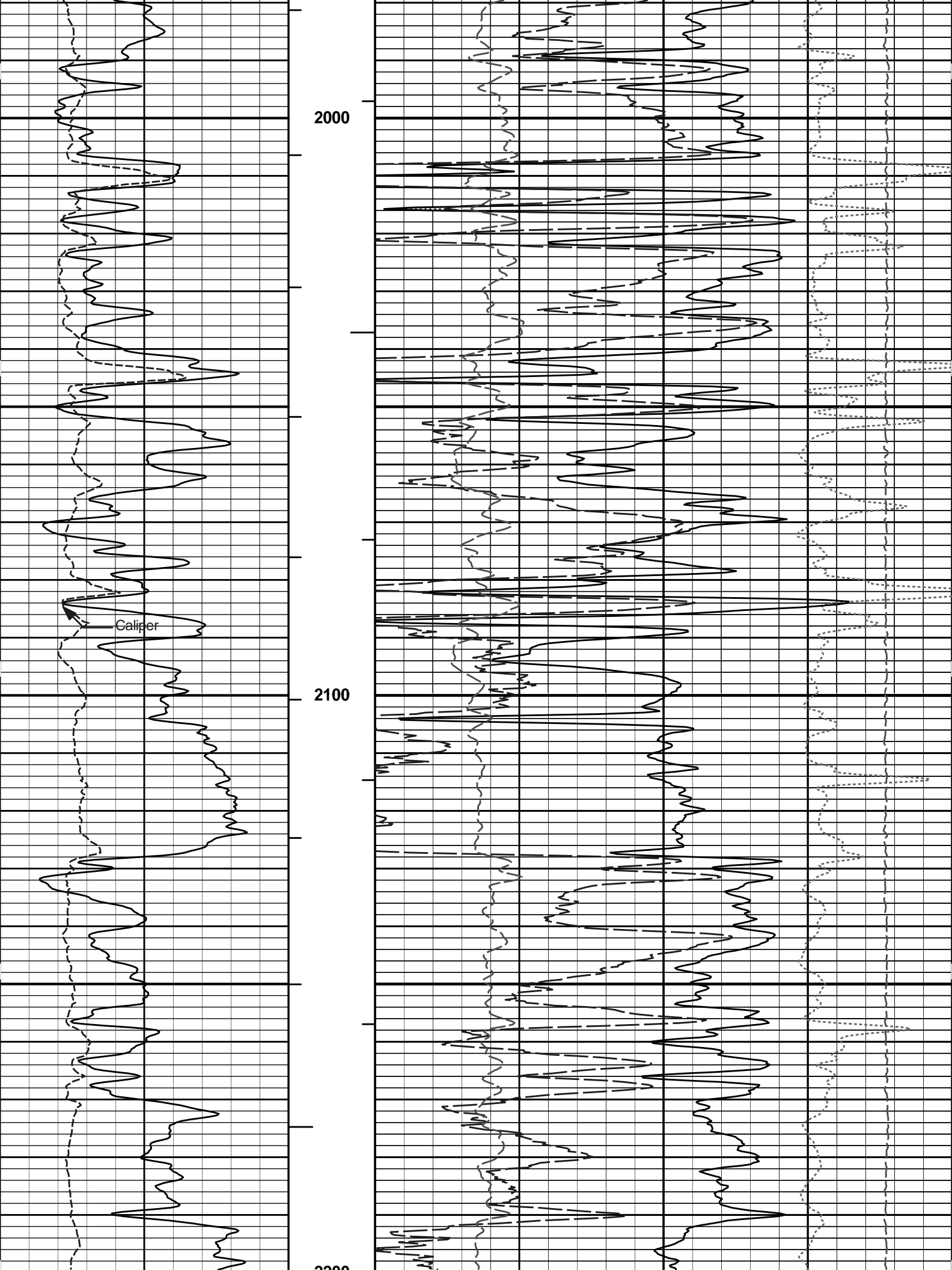

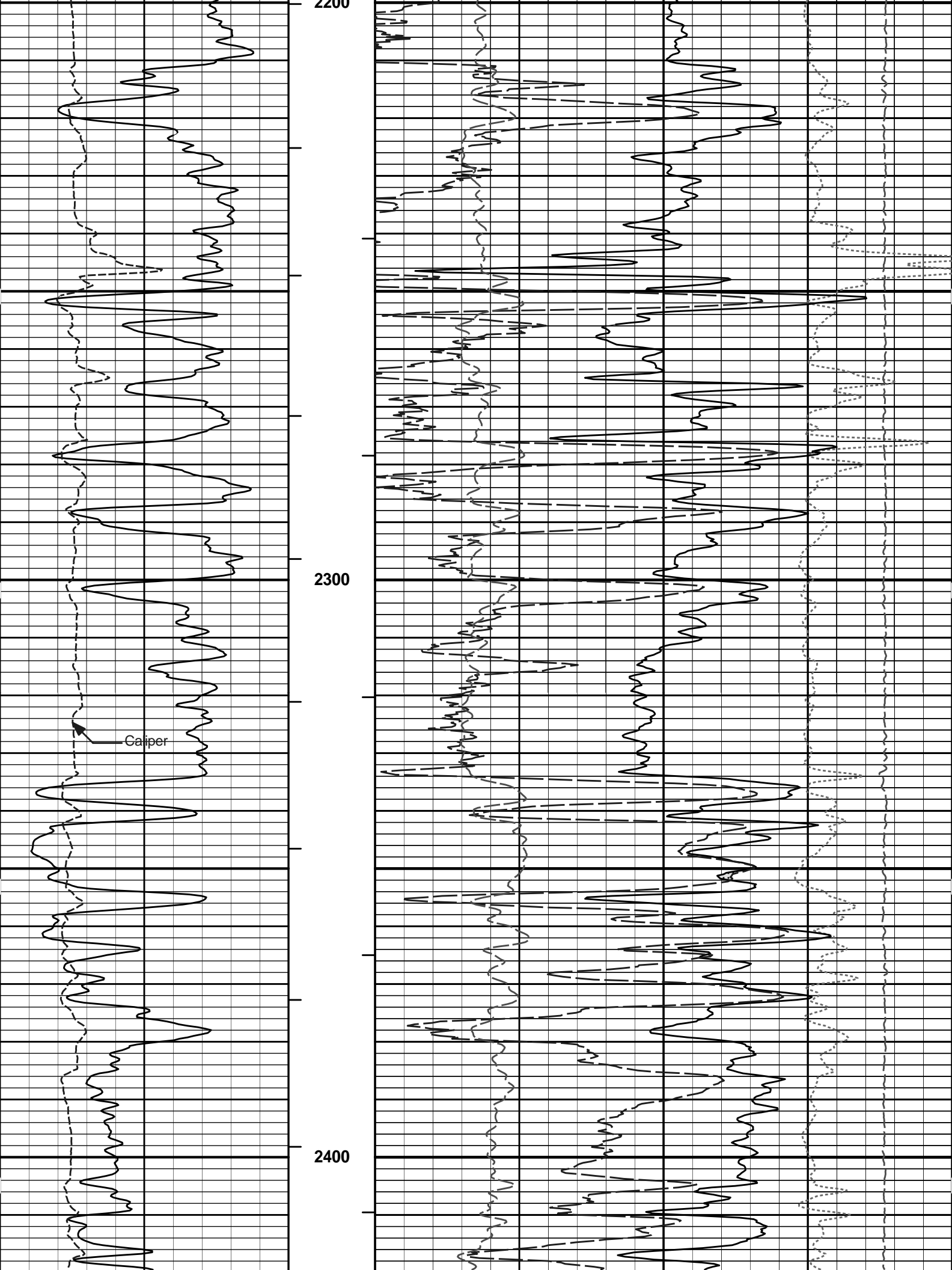

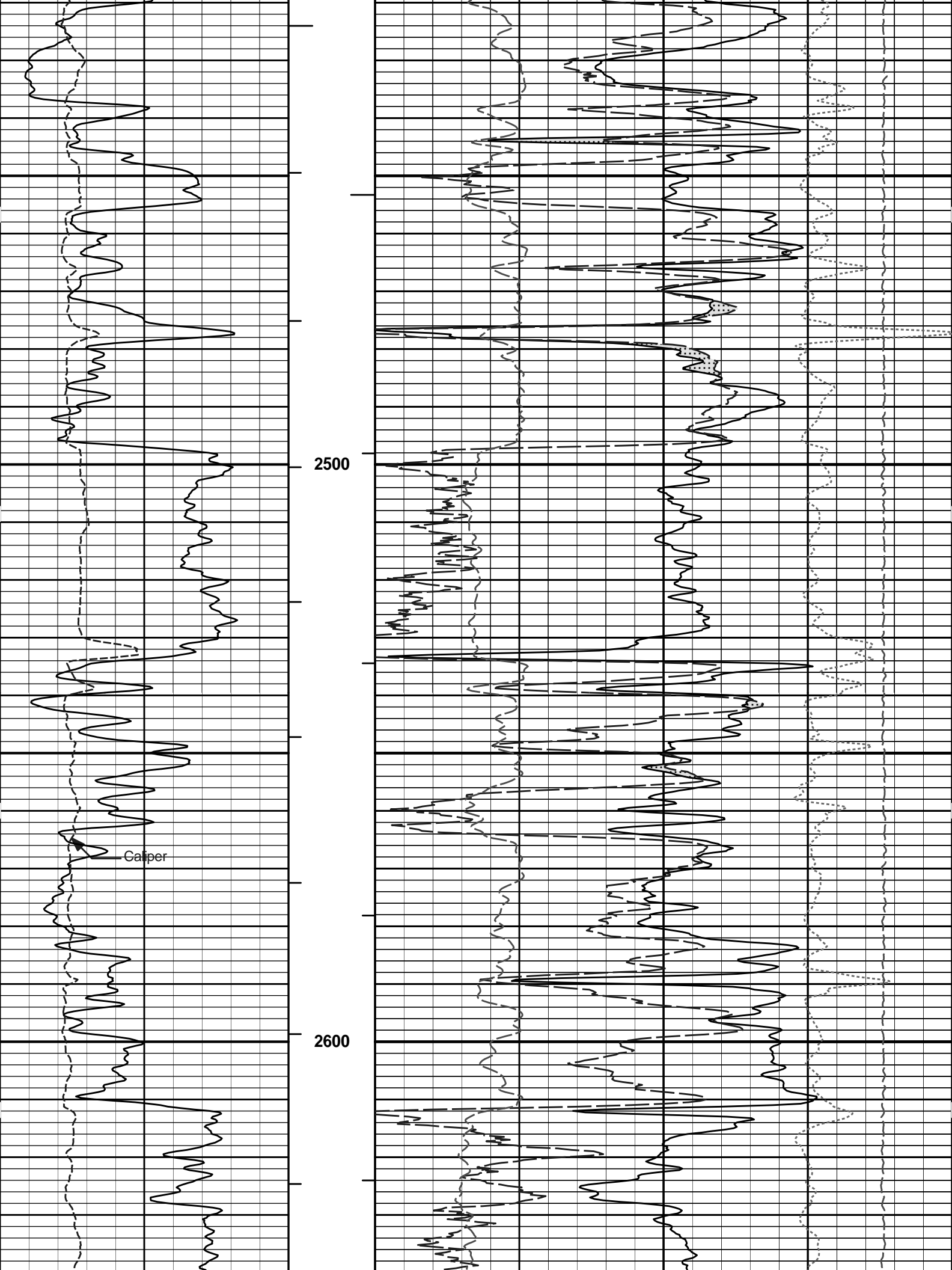

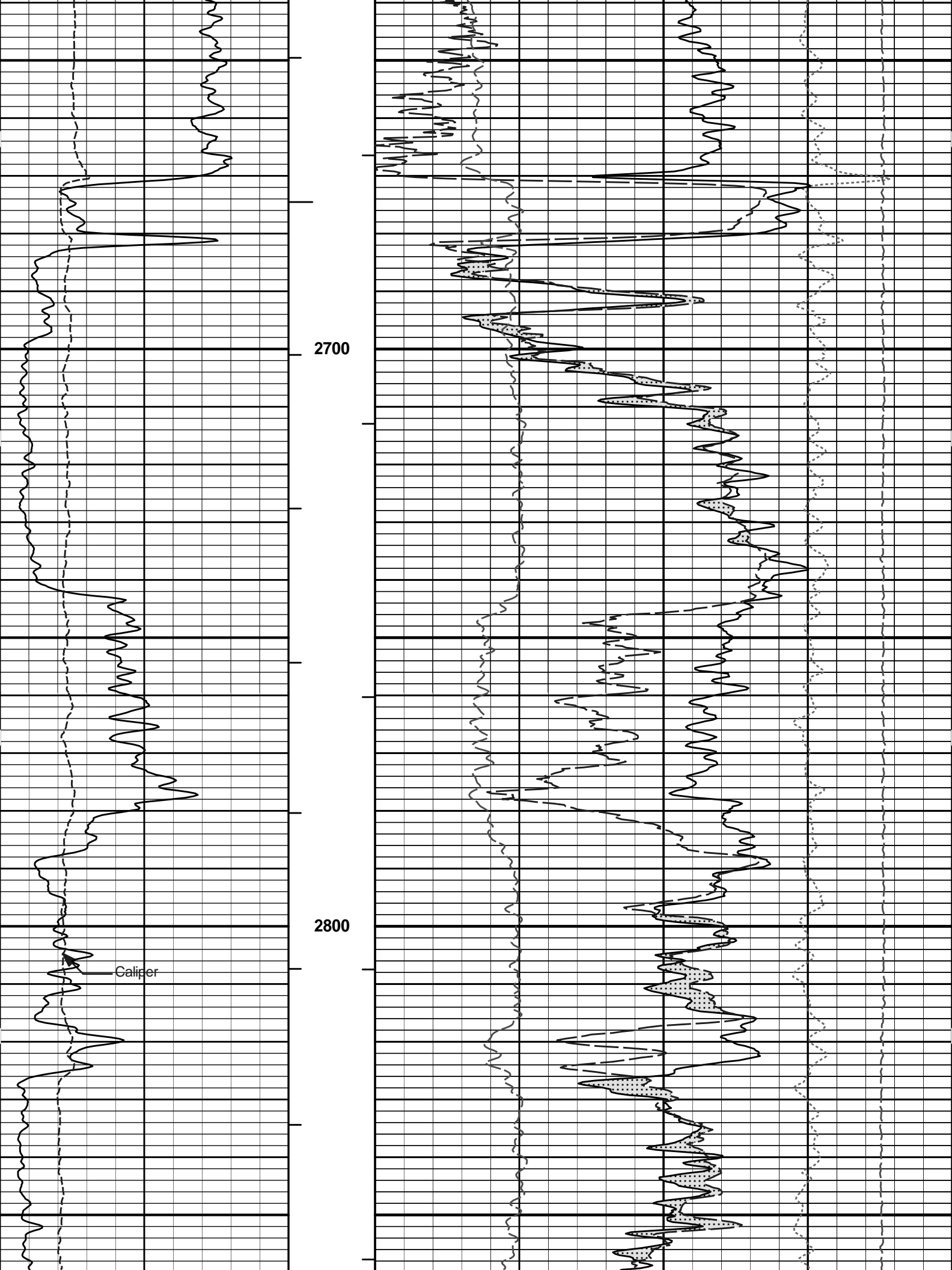

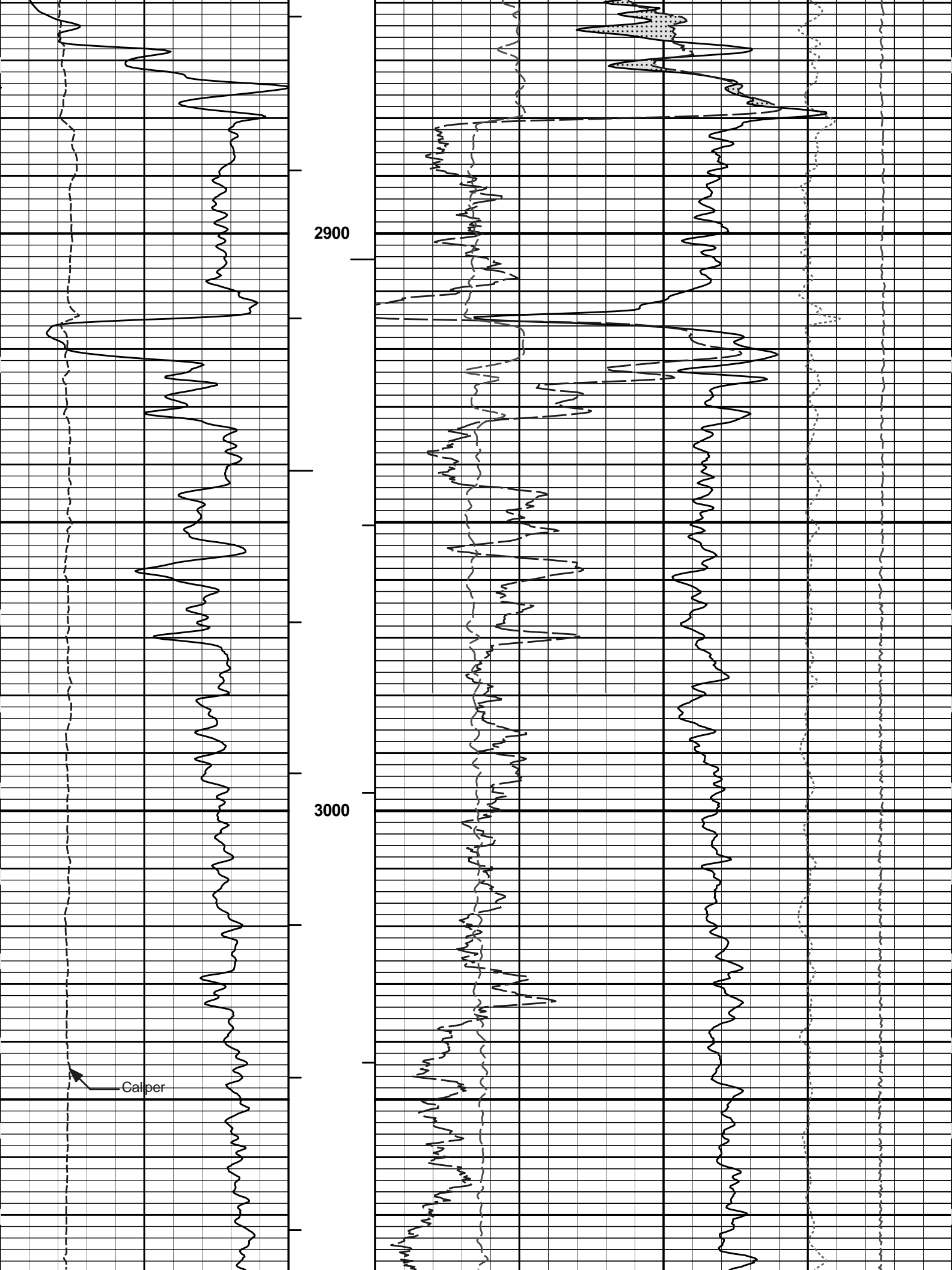

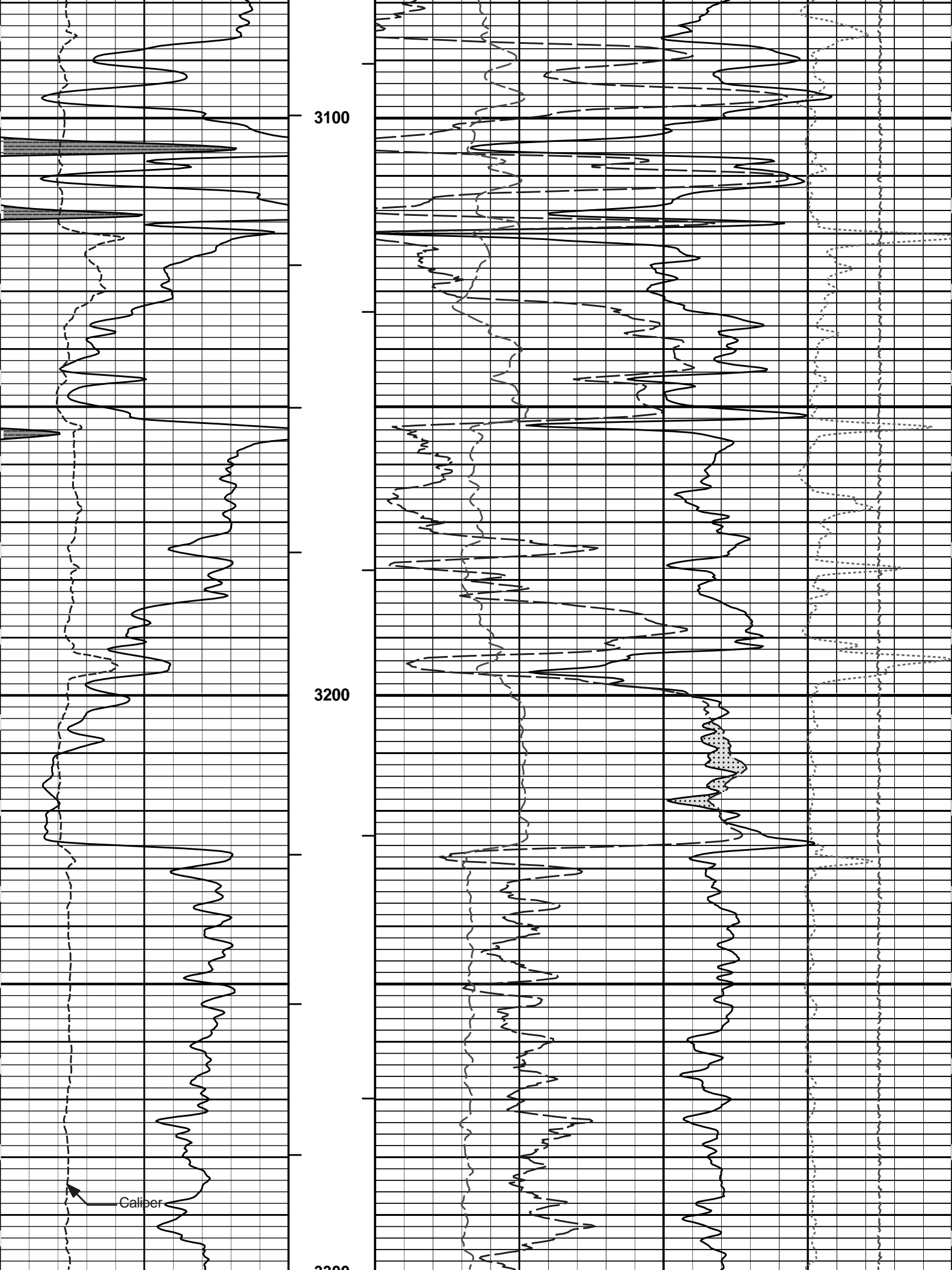

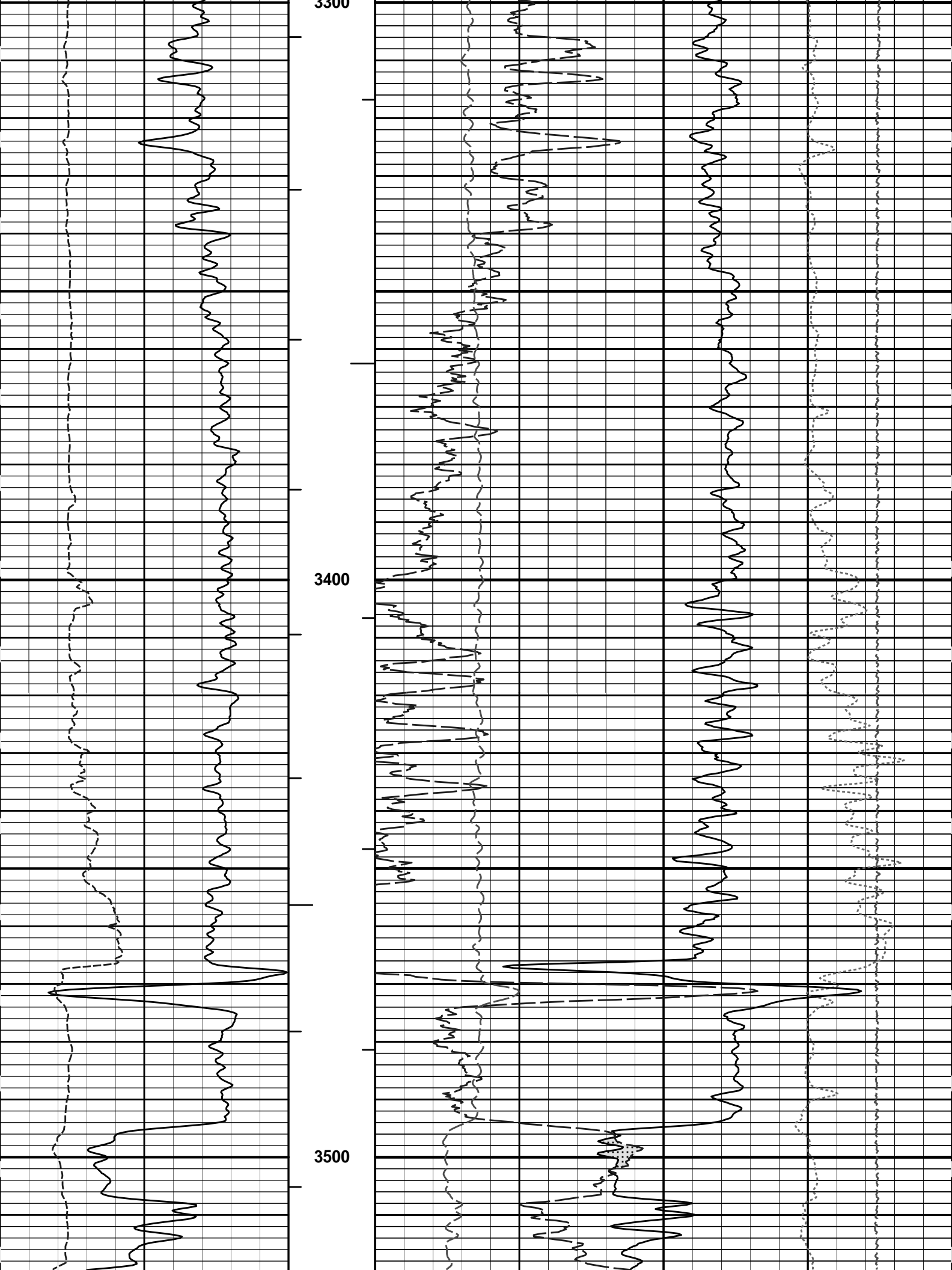

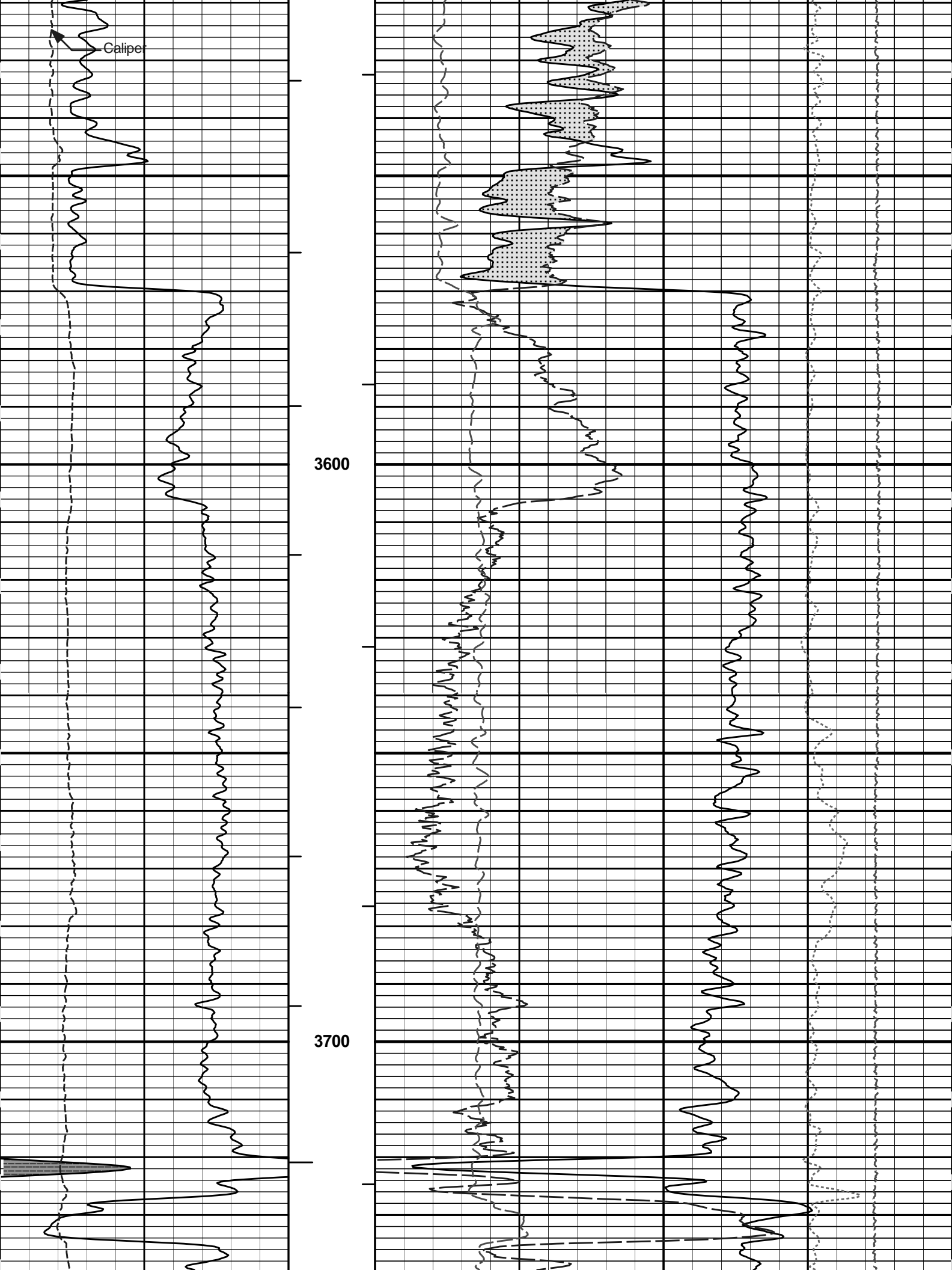

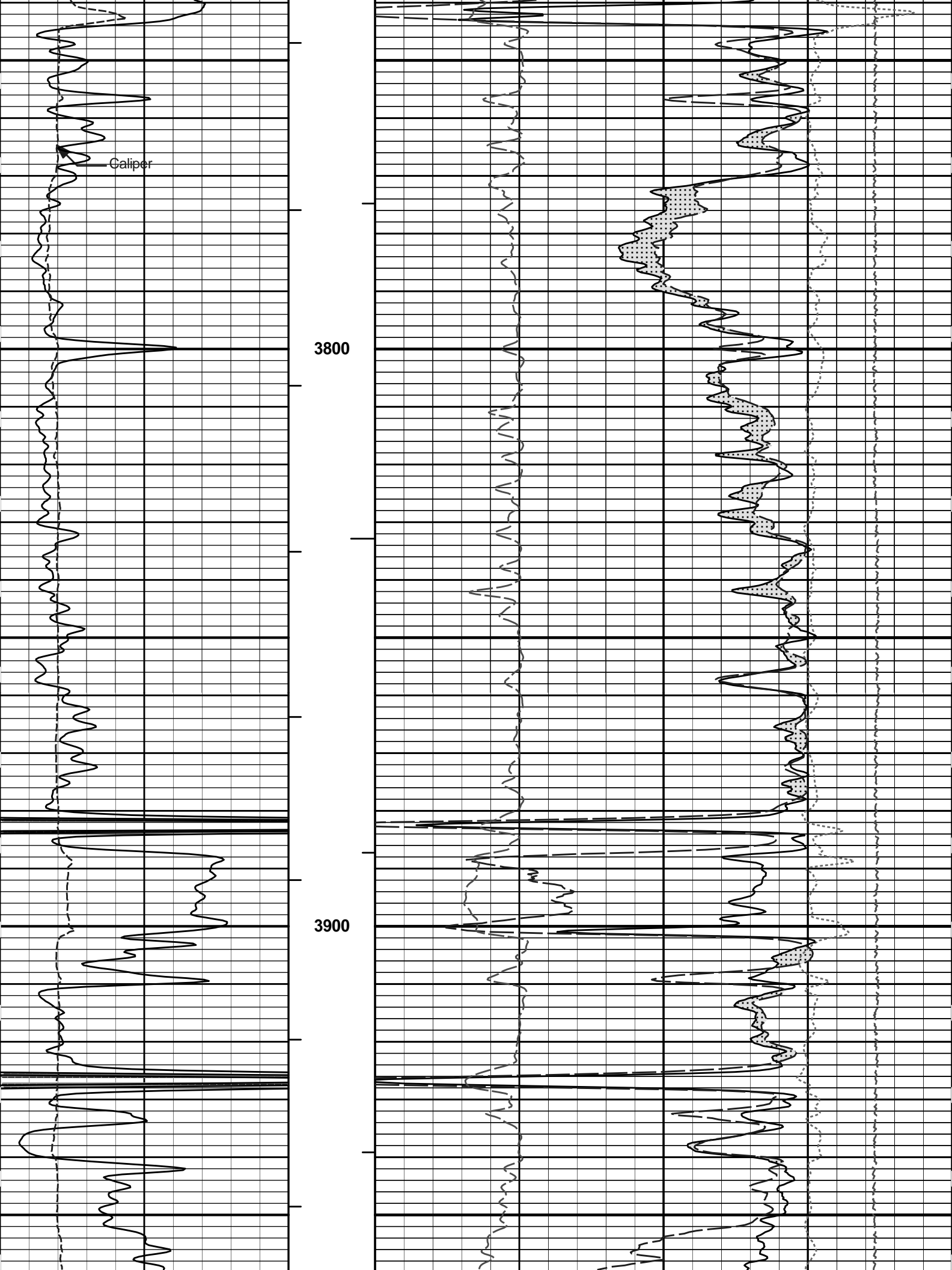

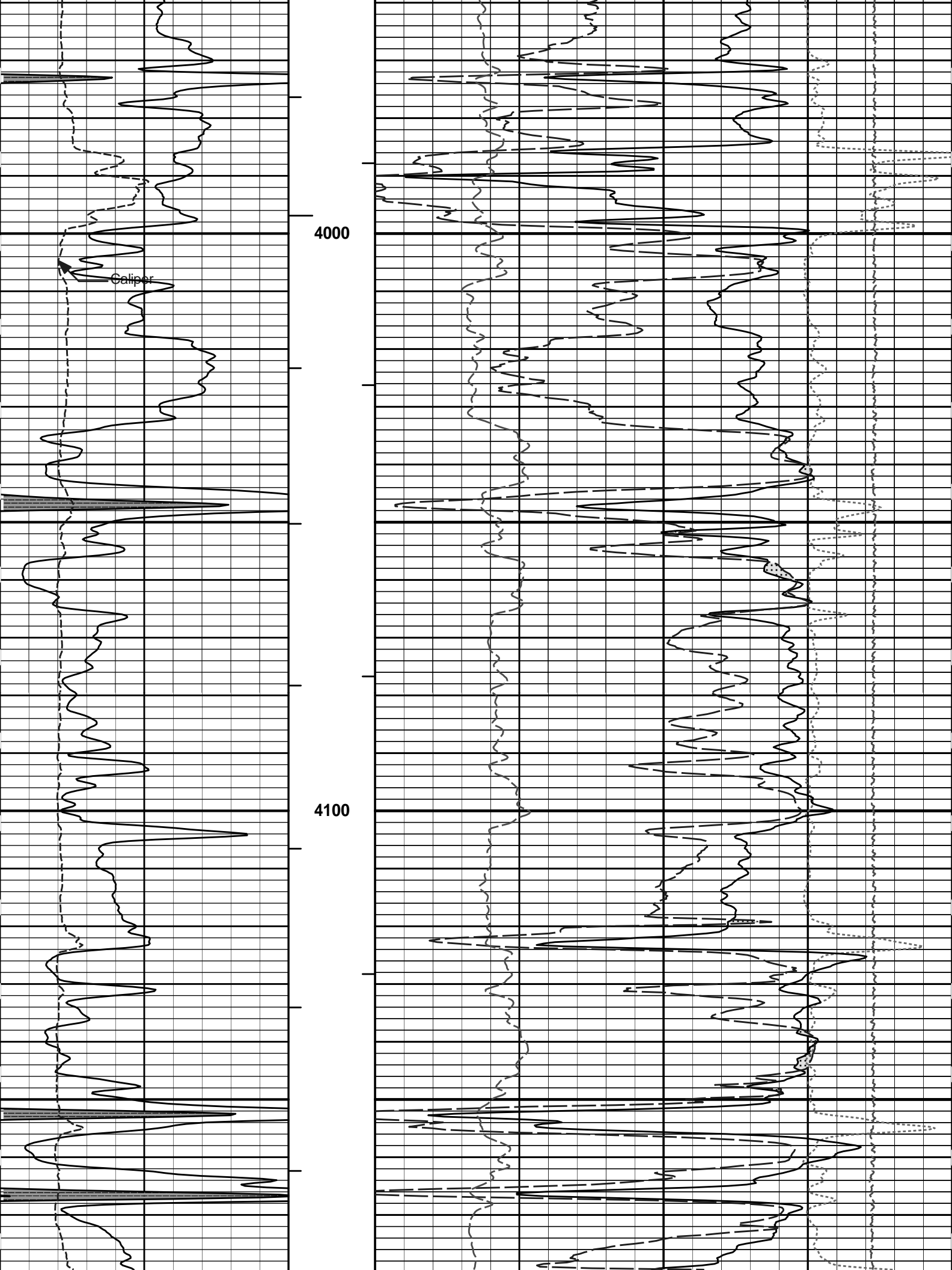

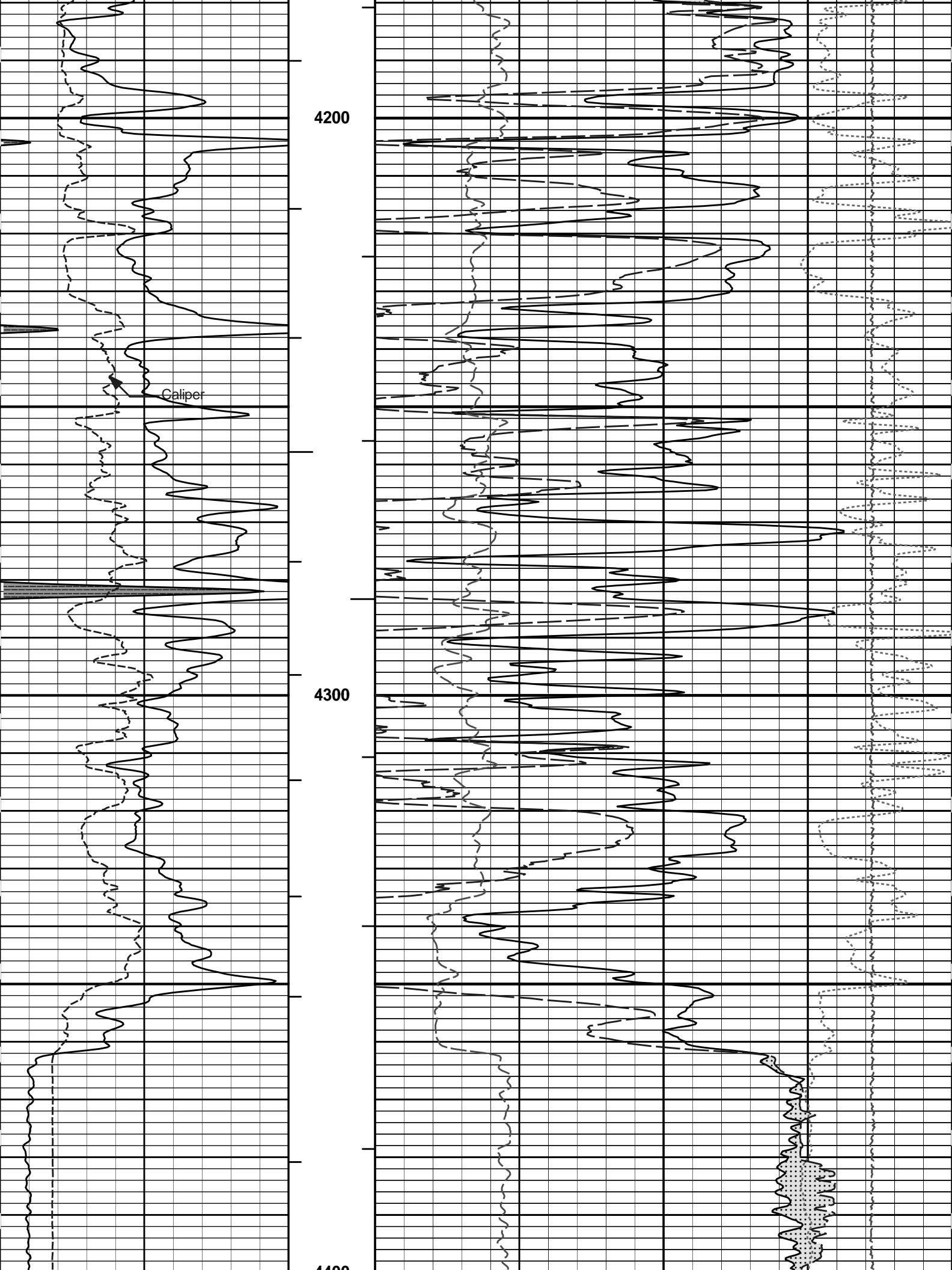

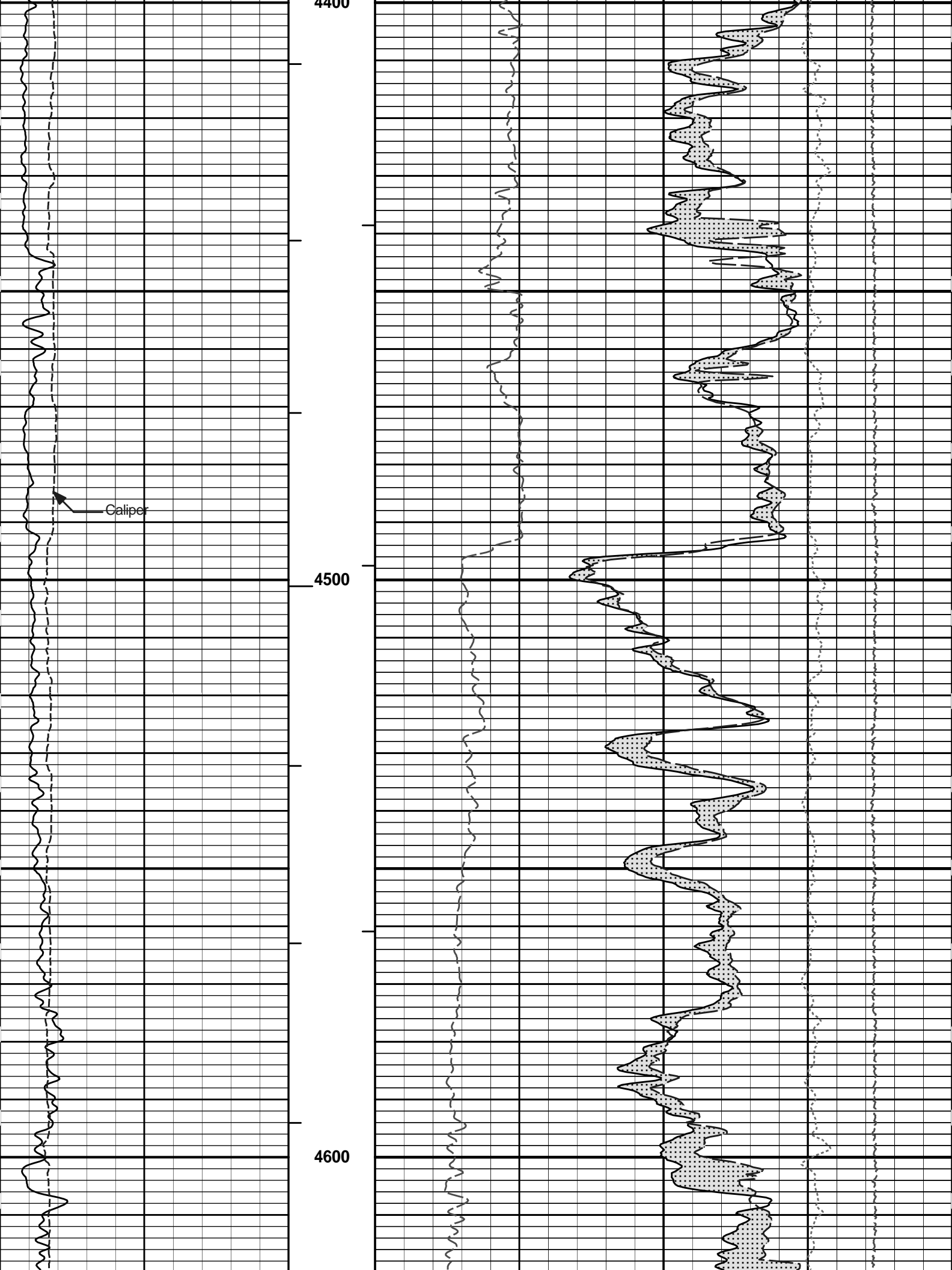

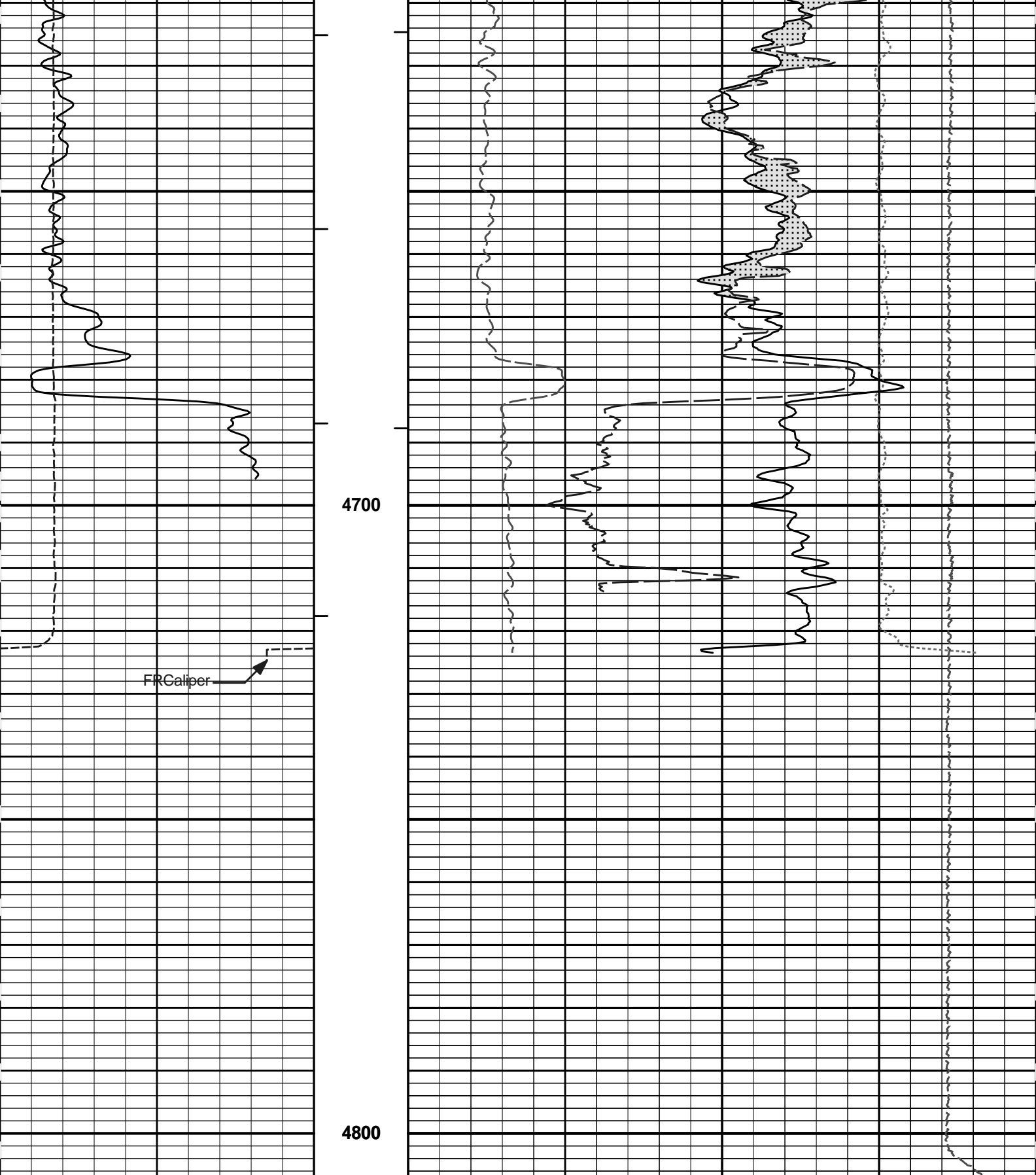

FRCaliper

4700

4800

6	Caliper	16	MD	0	Pe	10	-0.25	DensityCorr	0.25
	inches		1 : 240					gram per cc	
0	Gamma API	150	AHVT			15K		Tension	0
	api							pounds	
	SHALE		BHVT	30	DensityPorosity				-10
					%				
					Neutron Porosity				

30	Neutron Porosity	-10
	%	
CROSSOVER		

HALLIBURTON

Plot Time: 18-Jul-13 00:58:04
 Plot Range: 620 ft to 4806.83 ft
 Data: FLINN_A_3306\Well Based\CASING\
 Plot File: \\PORO\Poro_IQ_5_MAIN_LIB

5 INCH MAIN LOG

HALLIBURTON

Plot Time: 18-Jul-13 00:58:04
 Plot Range: 4500 ft to 4807.92 ft
 Data: FLINN_A_3306\Well Based\REPEAT\
 Plot File: \\PORO\Poro_IQ_5_REP_LIB

REPEAT SECTION

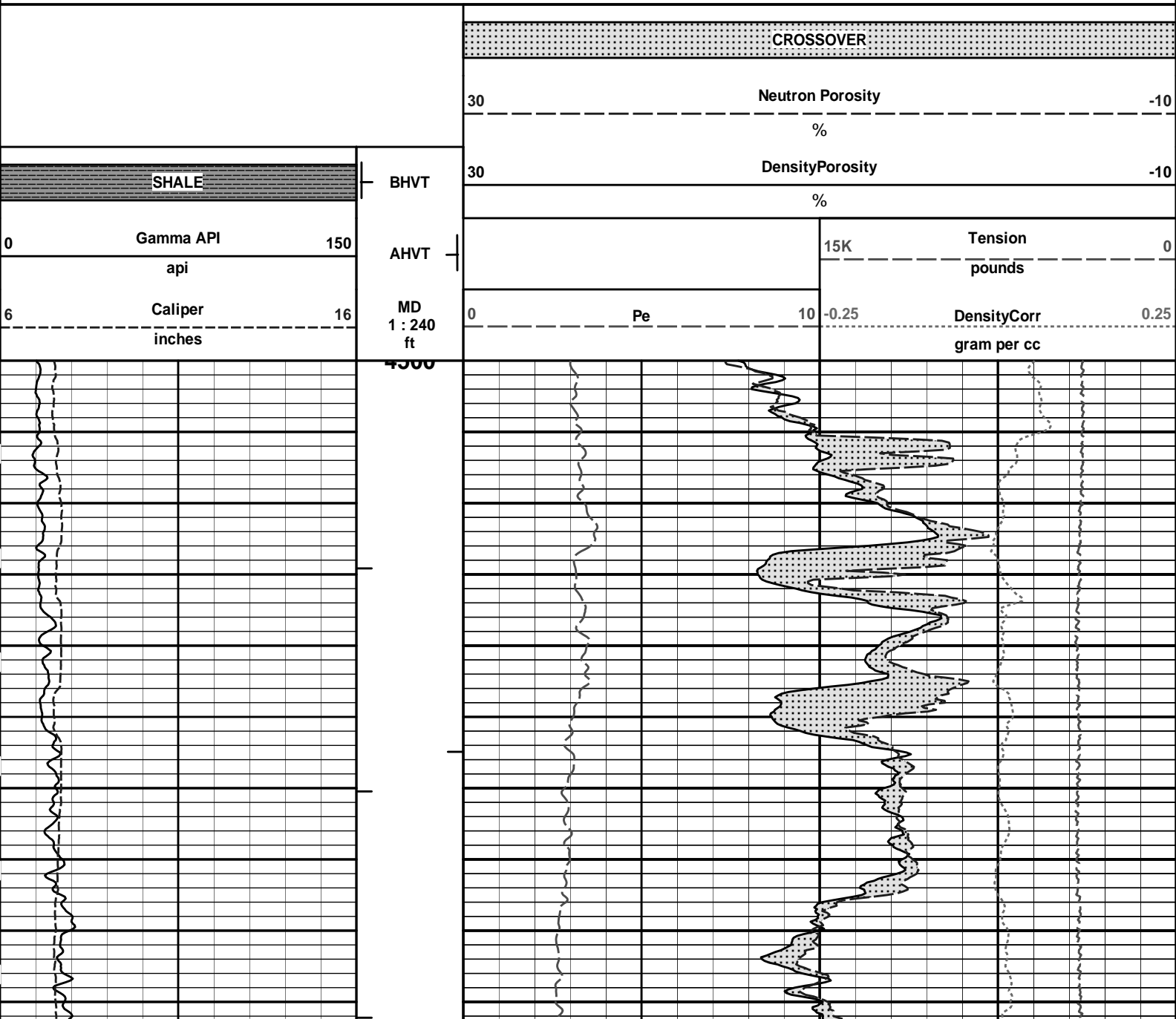

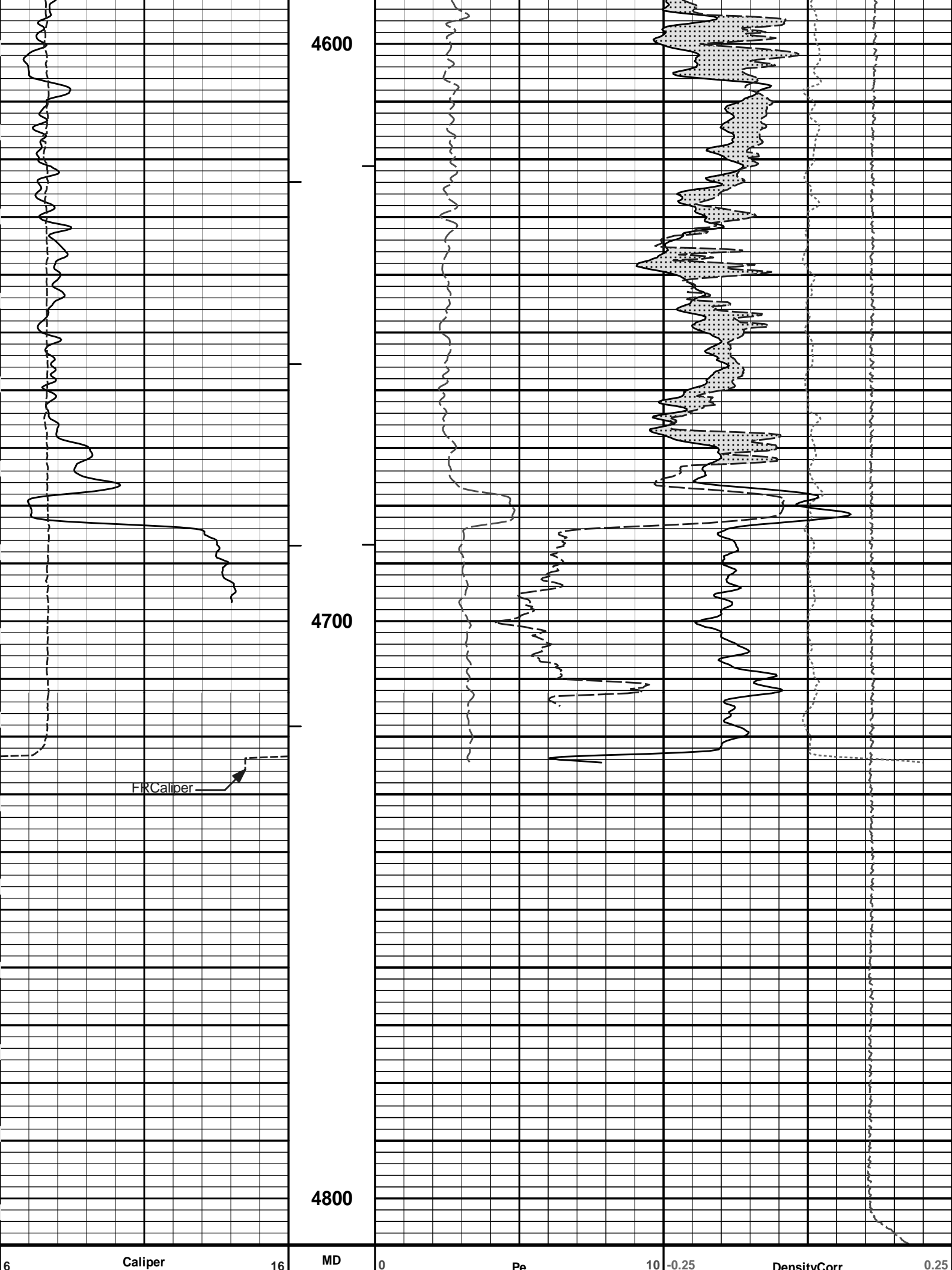

inches	1 : 240	ft	gram per cc
0	Gamma API	150	Tension
api	AHVT	15K	pounds
SHALE	BHVT	30	DensityPorosity
			%
		30	Neutron Porosity
			%
			CROSSOVER

HALLIBURTON

Plot Time: 18-Jul-13 00:58:08
 Plot Range: 4500 ft to 4807.92 ft
 Data: FLINN_A_3306\Well Based\REPEAT\
 Plot File: \\PORO\Poro_IQ_5_REP_LIB

REPEAT SECTION

HALLIBURTON

Plot Time: 18-Jul-13 00:58:08
 Plot Range: 620 ft to 4806.83 ft
 Data: FLINN_A_3306\Well Based\CASING\
 Plot File: \\LOCAL\FLINN_A_3306\0001 SP-GTET-CSNG-DSN-SDL-FLEX-IDT-ICT-WAVE-ACRT-CH\PORO\BULKD_5_MAIN_LIB

5 INCH MAIN LOG

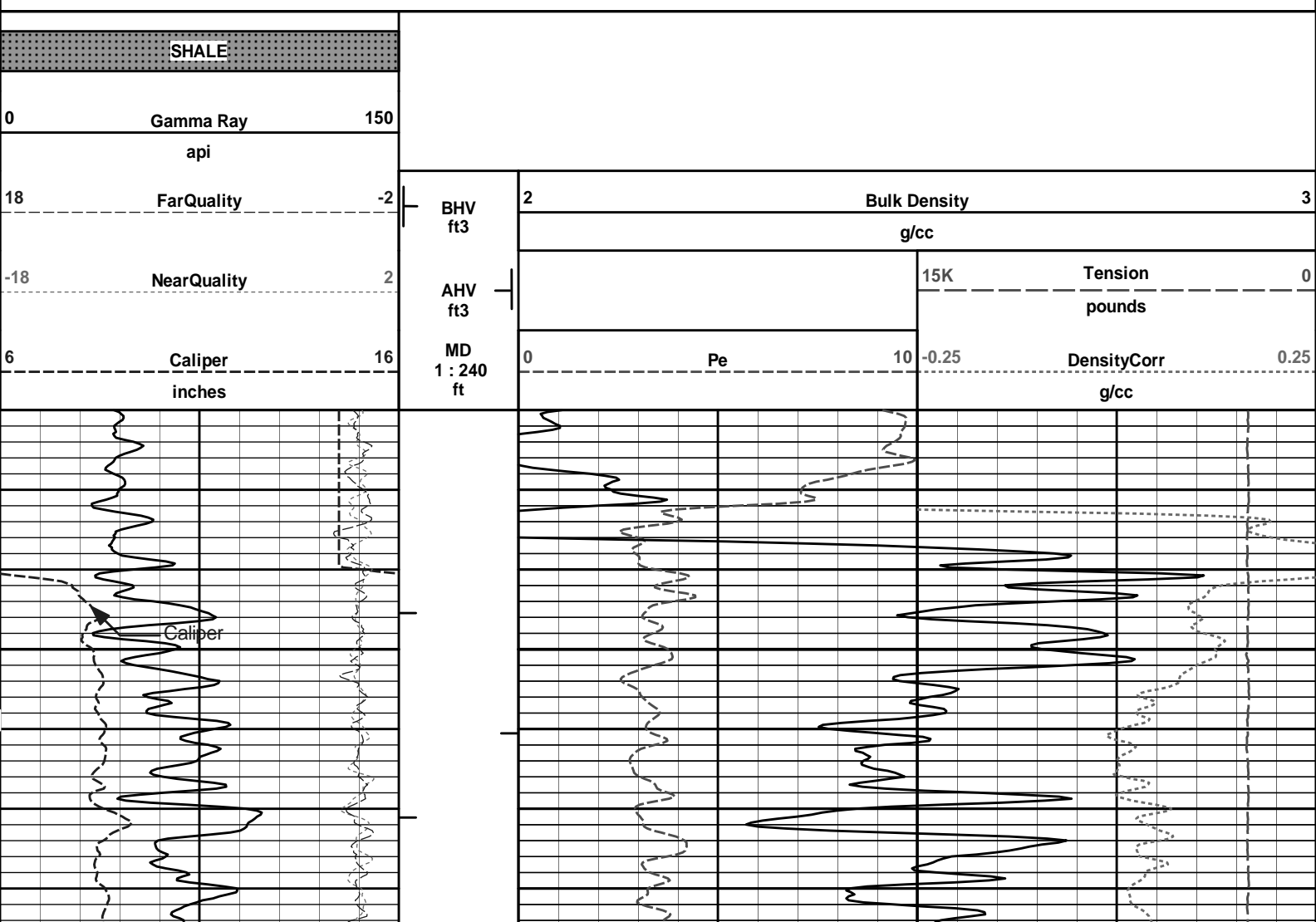

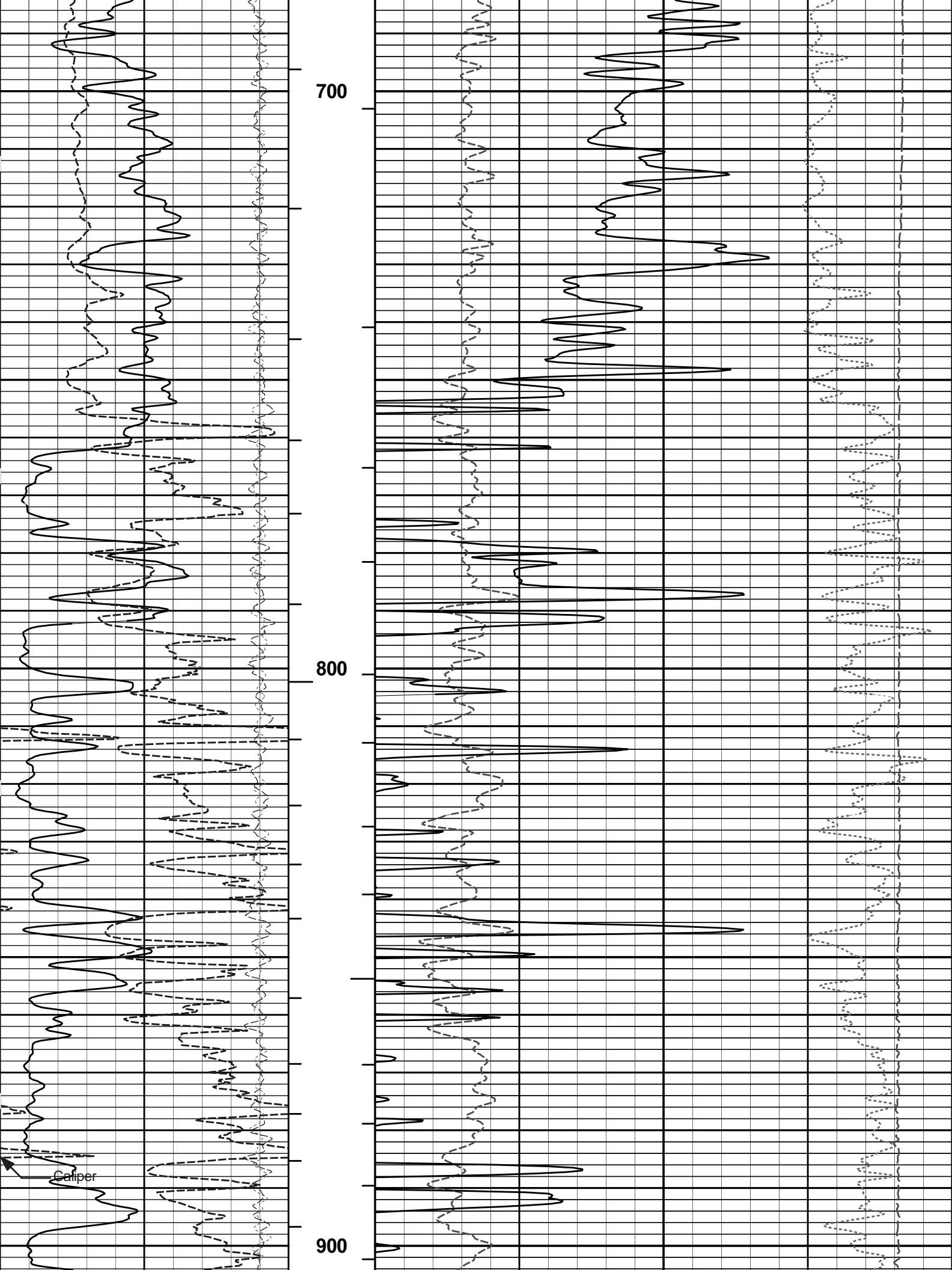

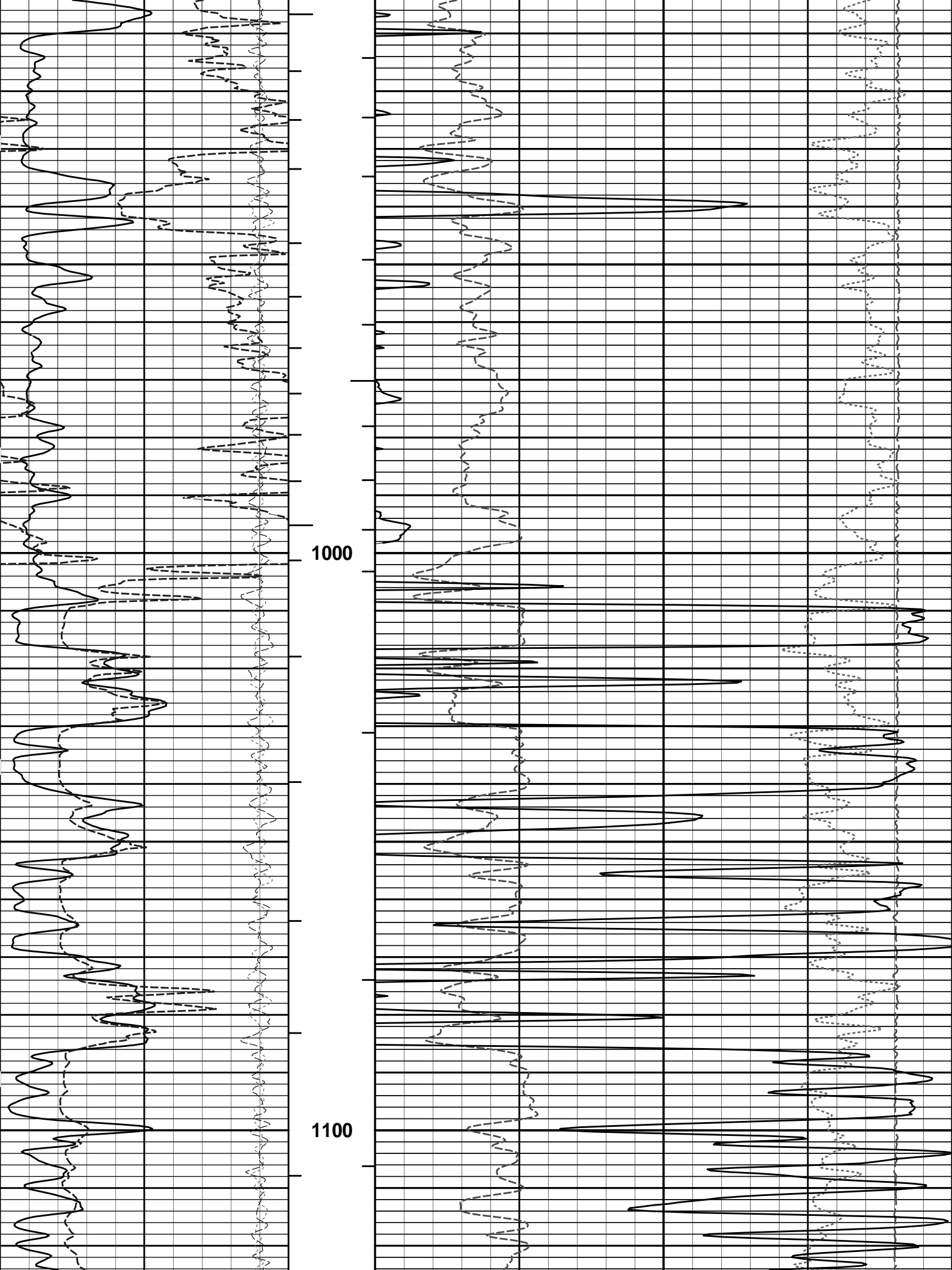

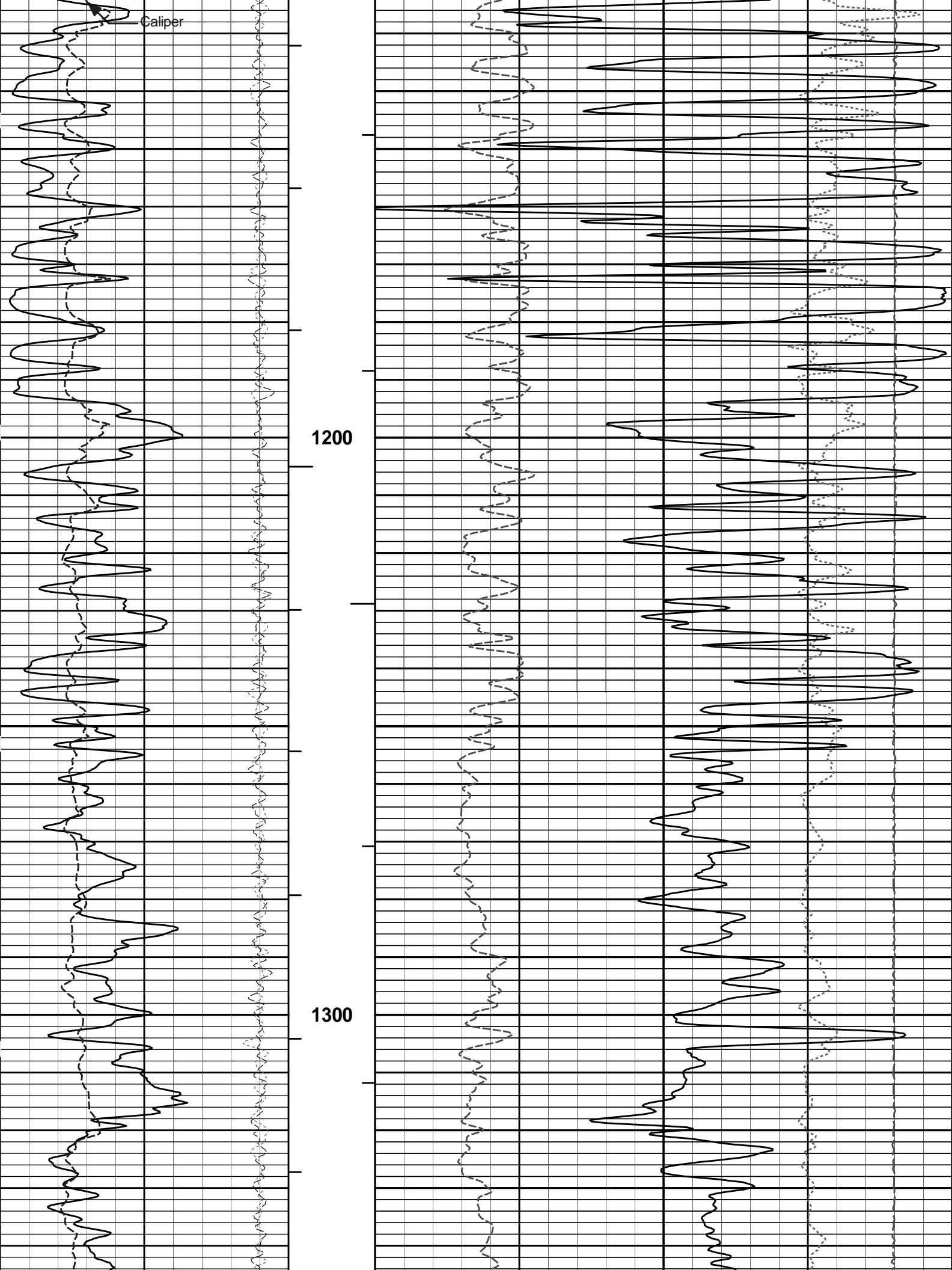

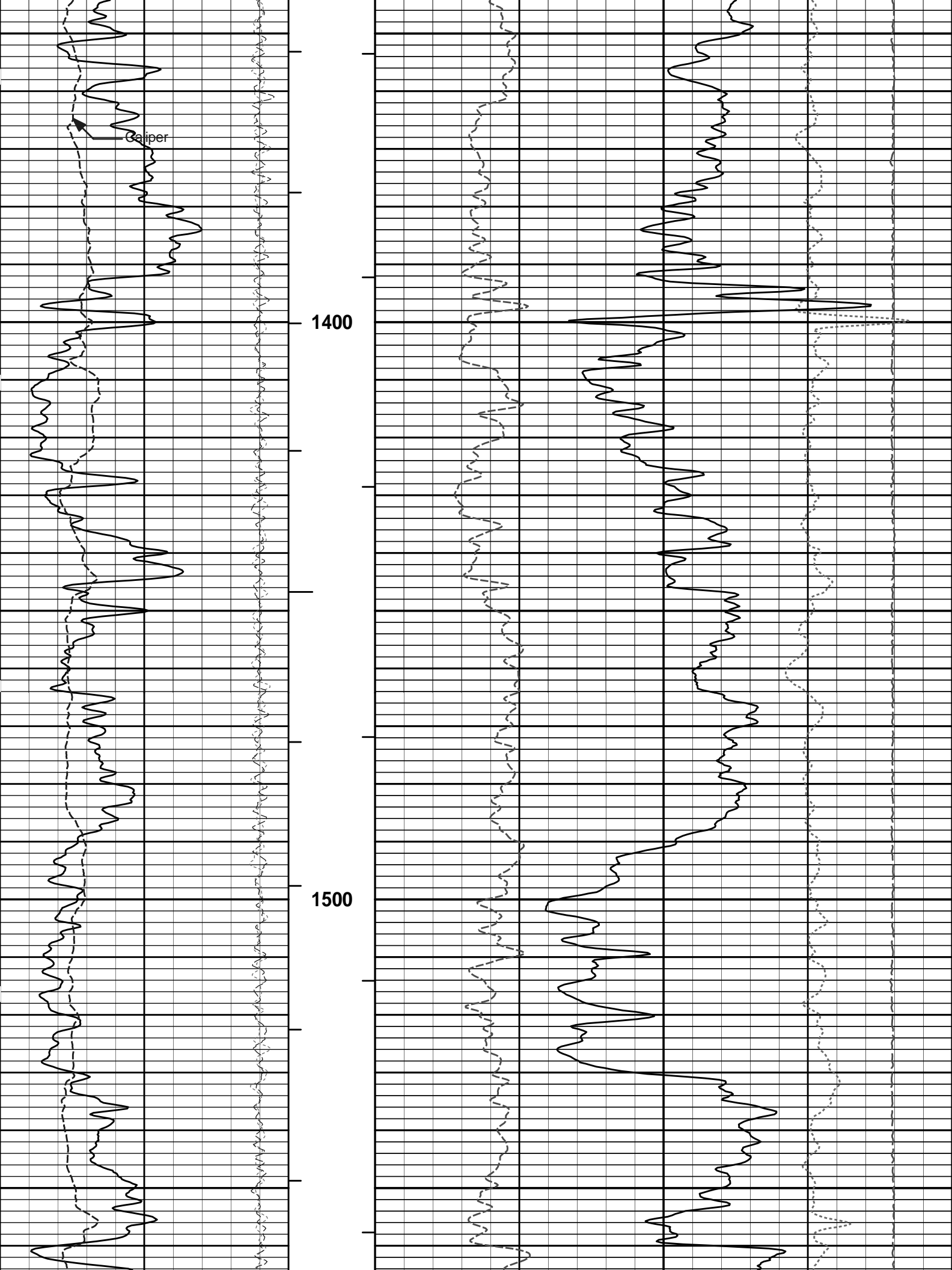

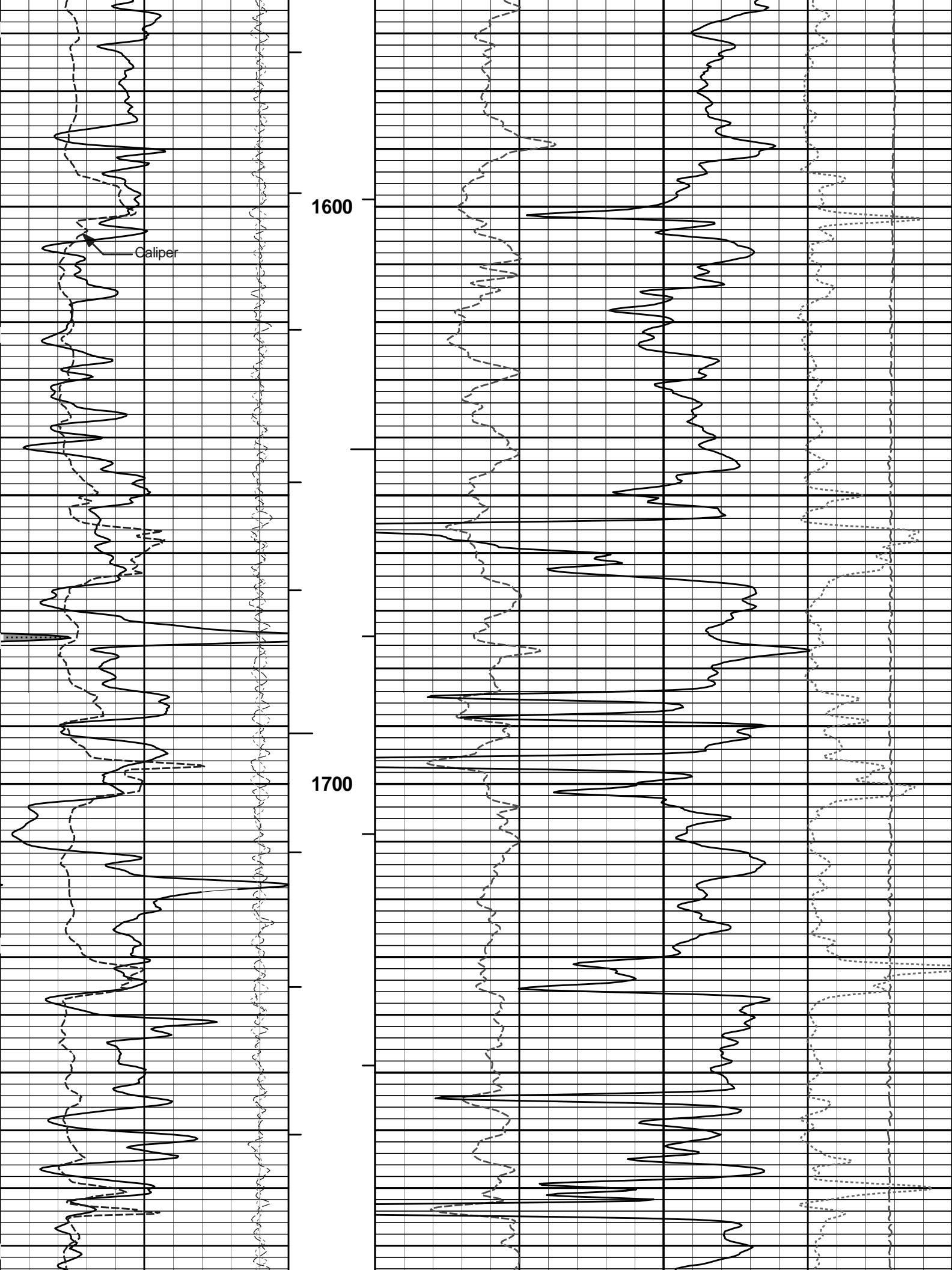

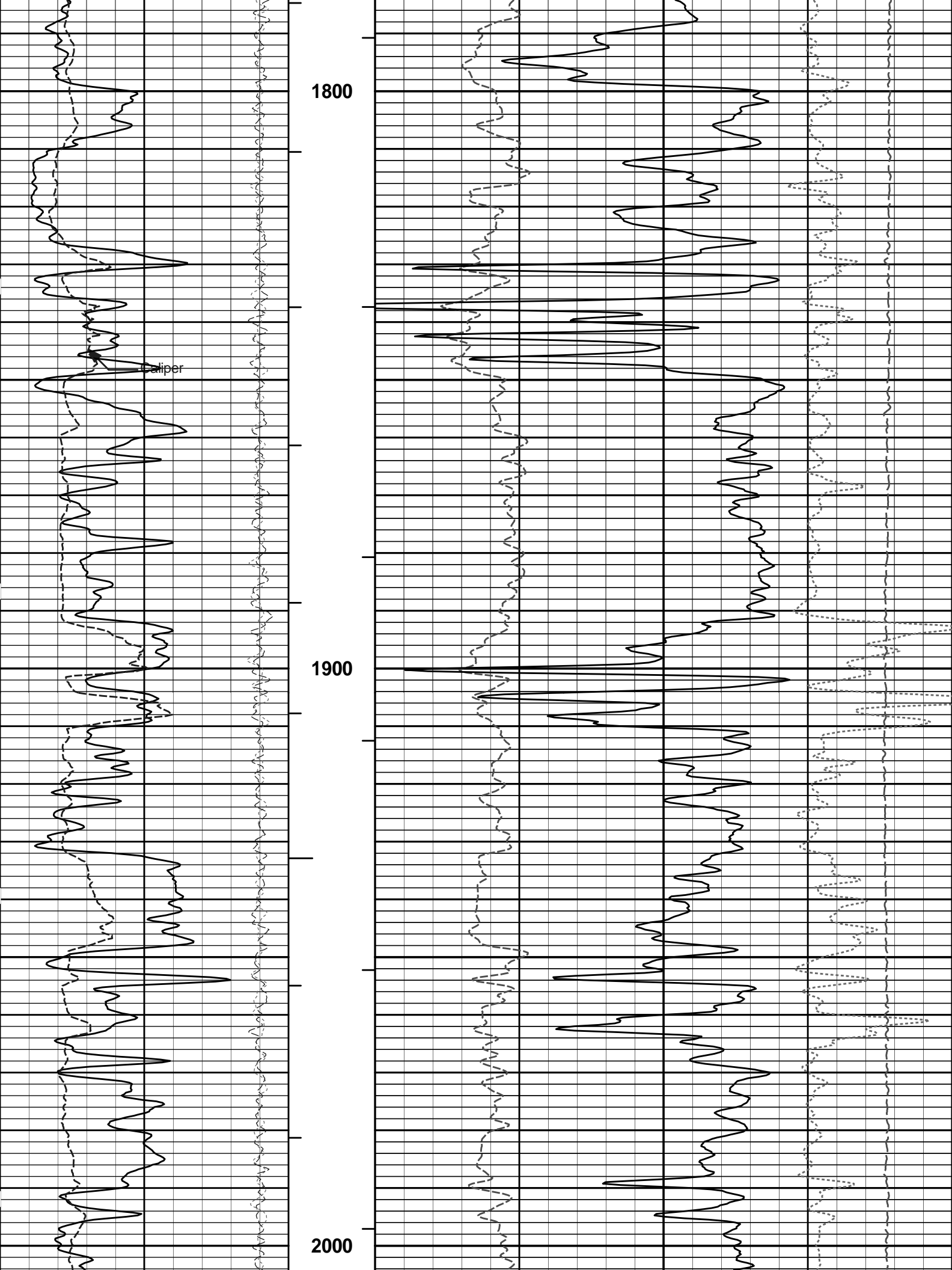

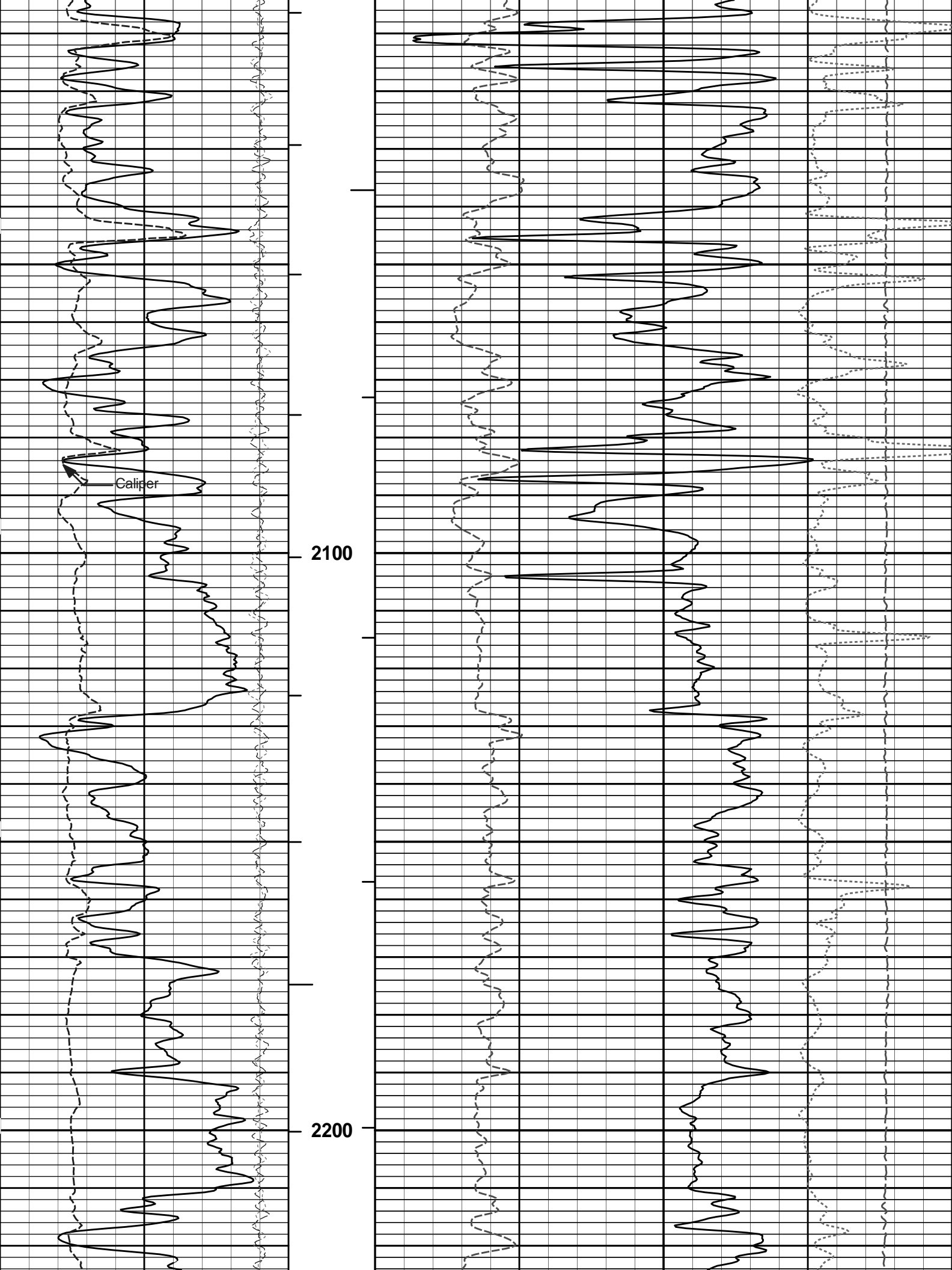

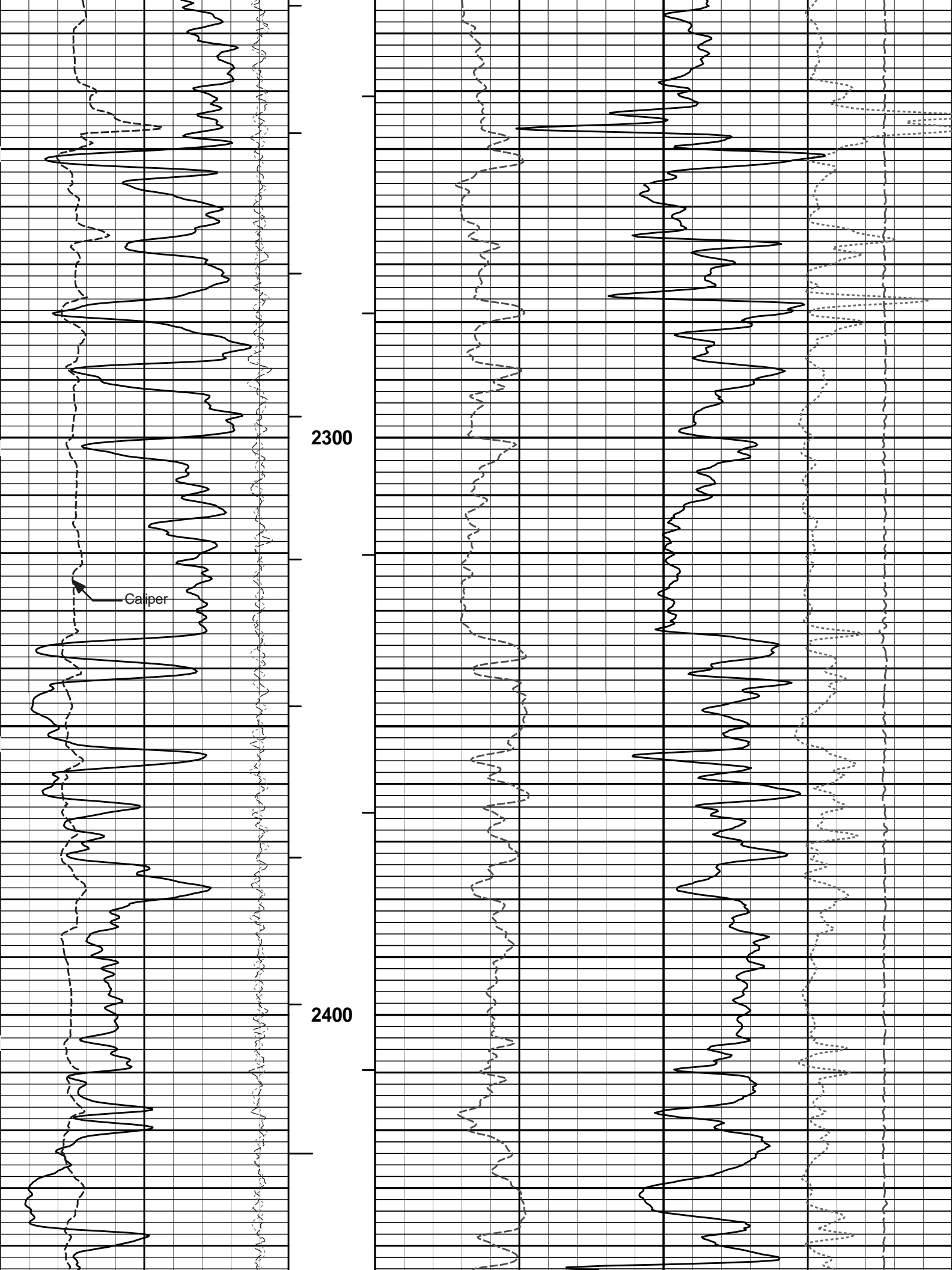

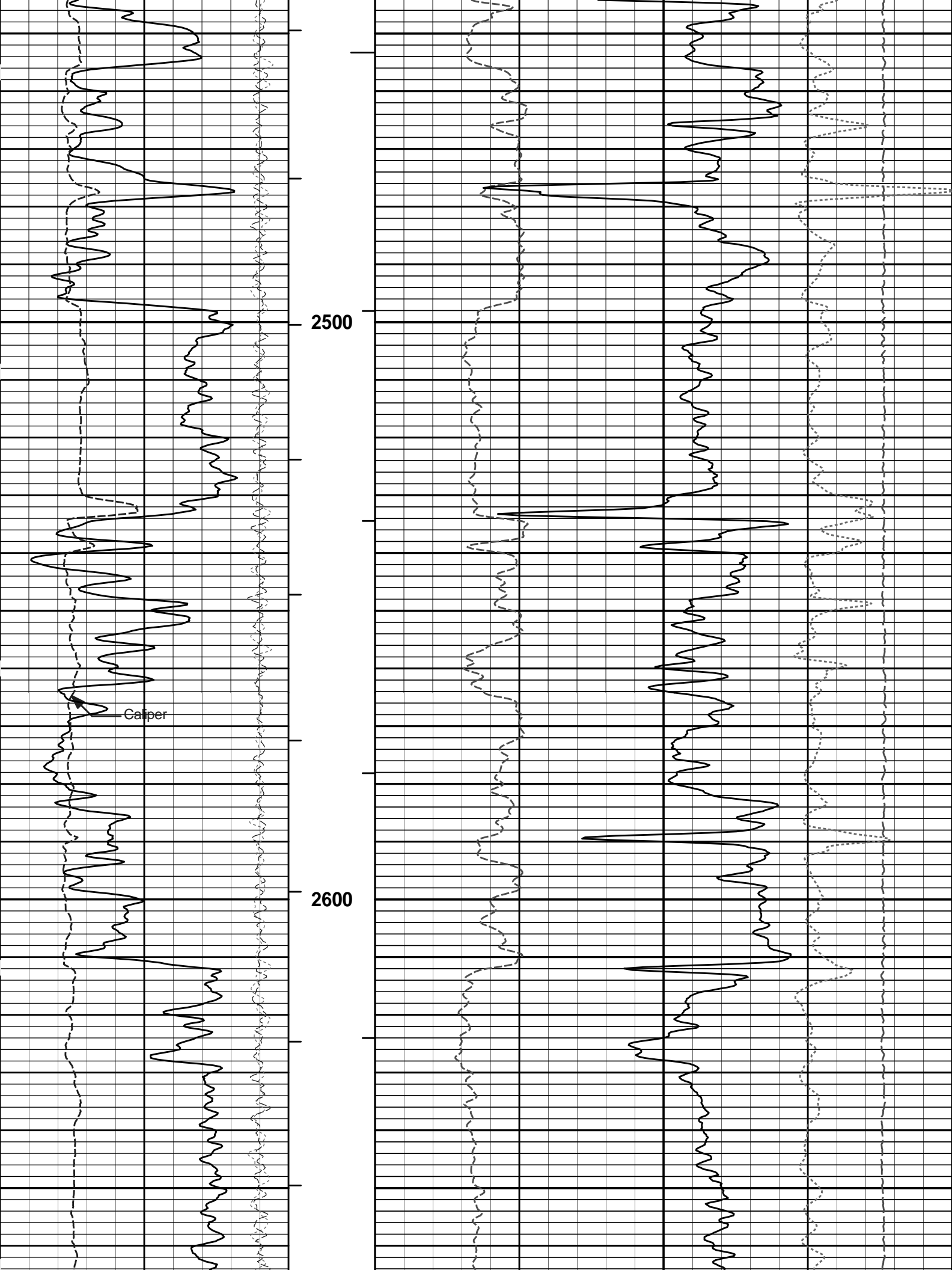

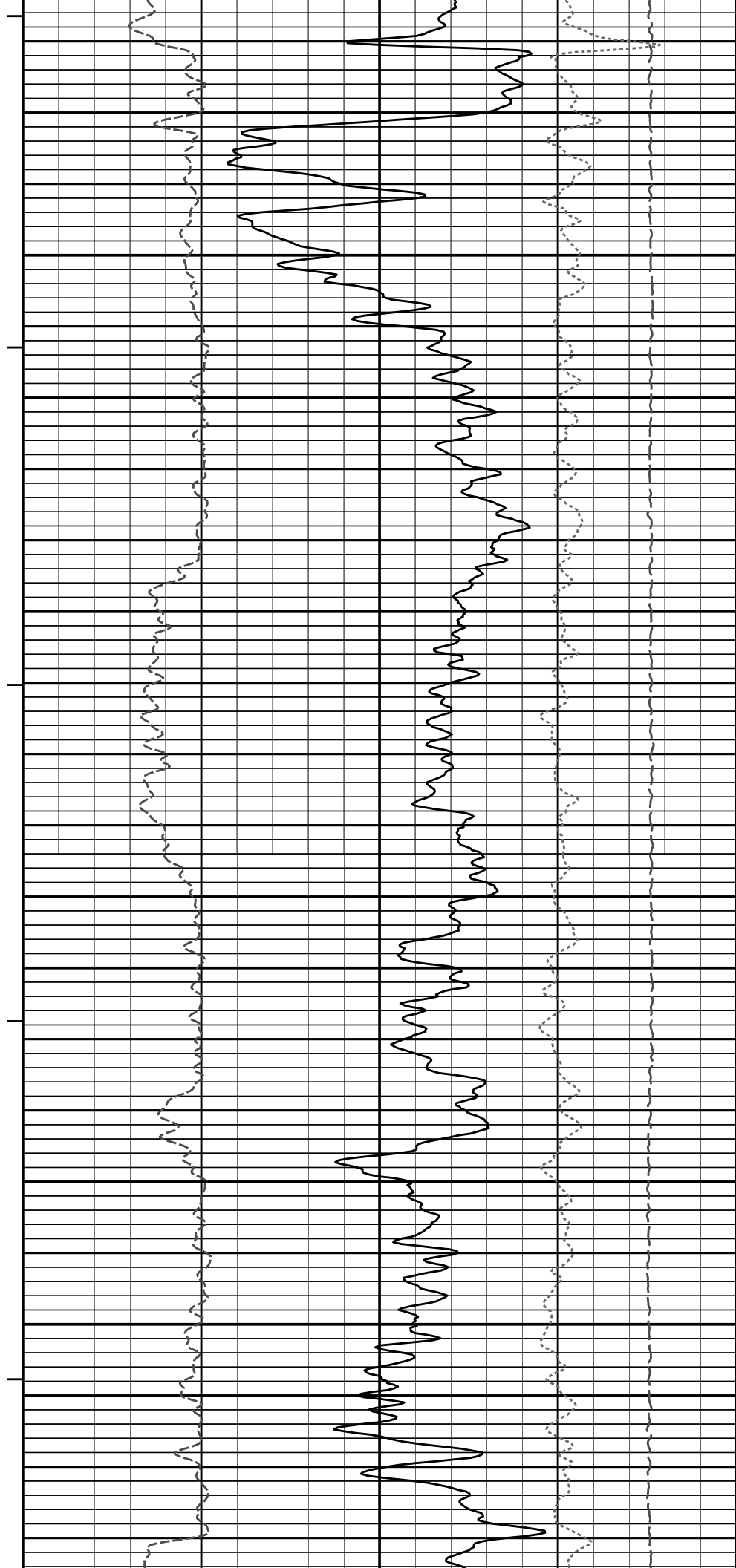
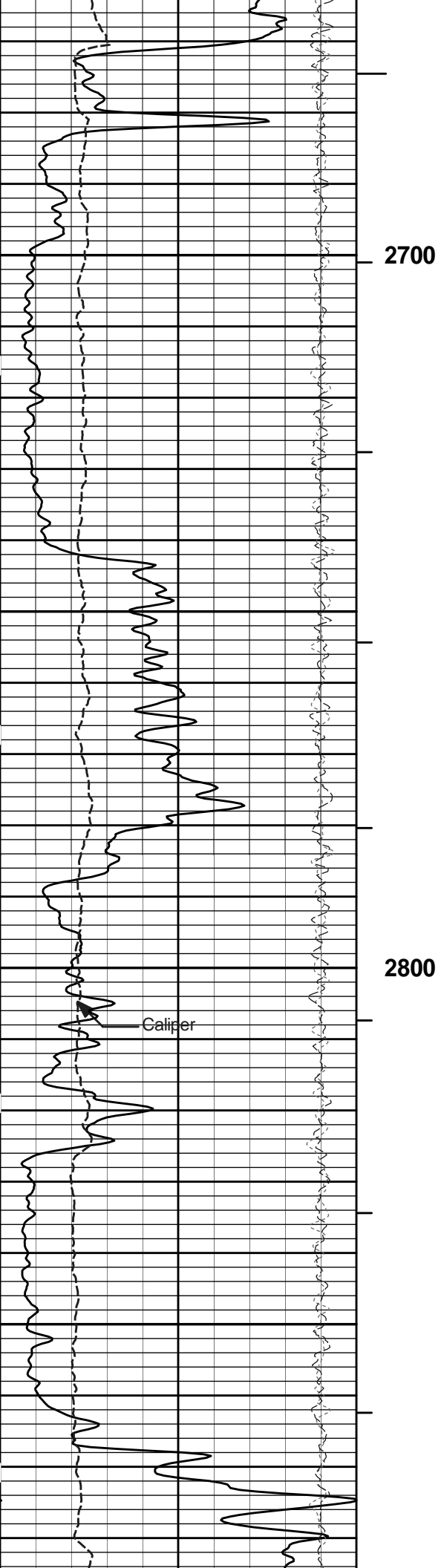

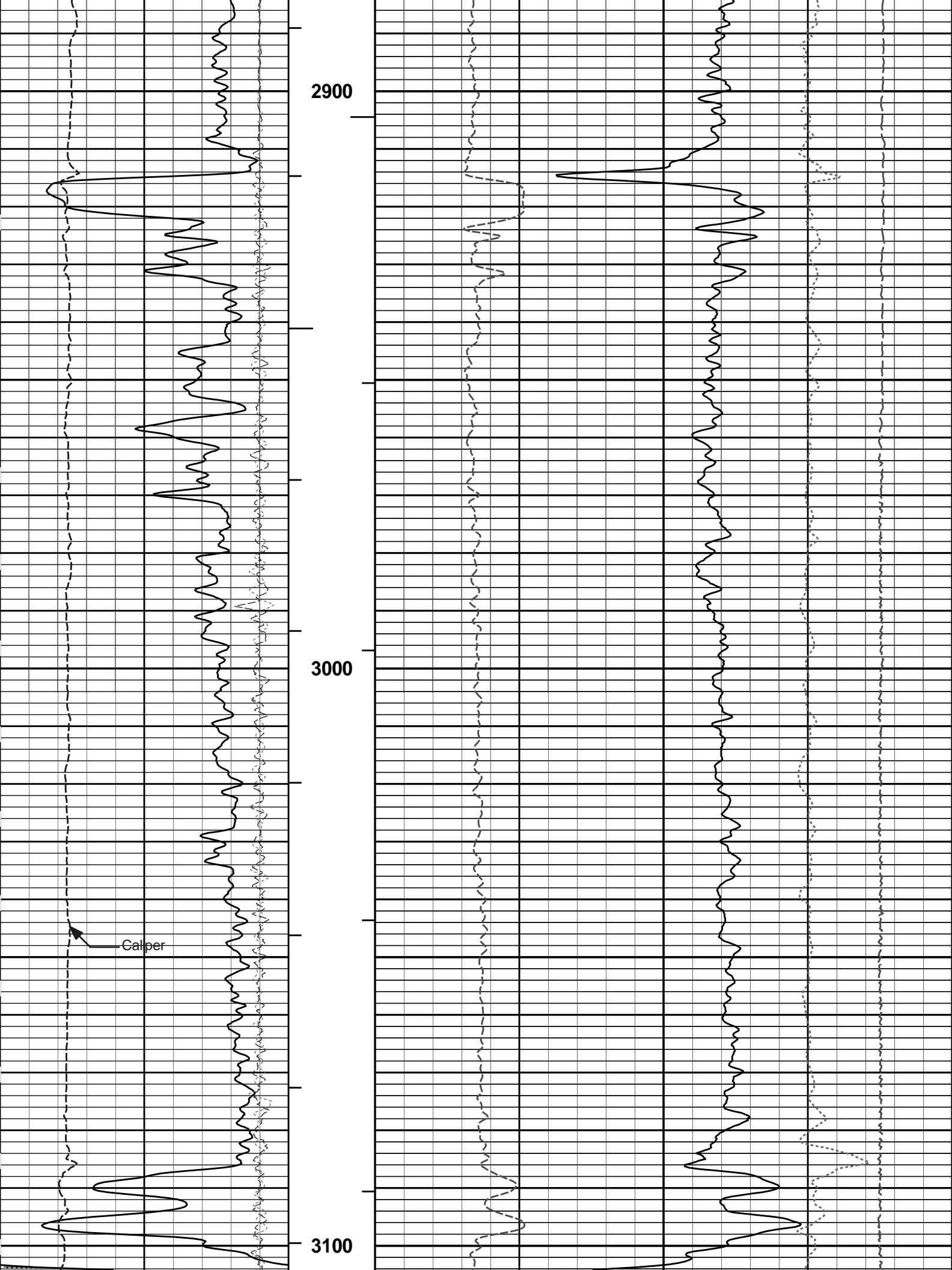

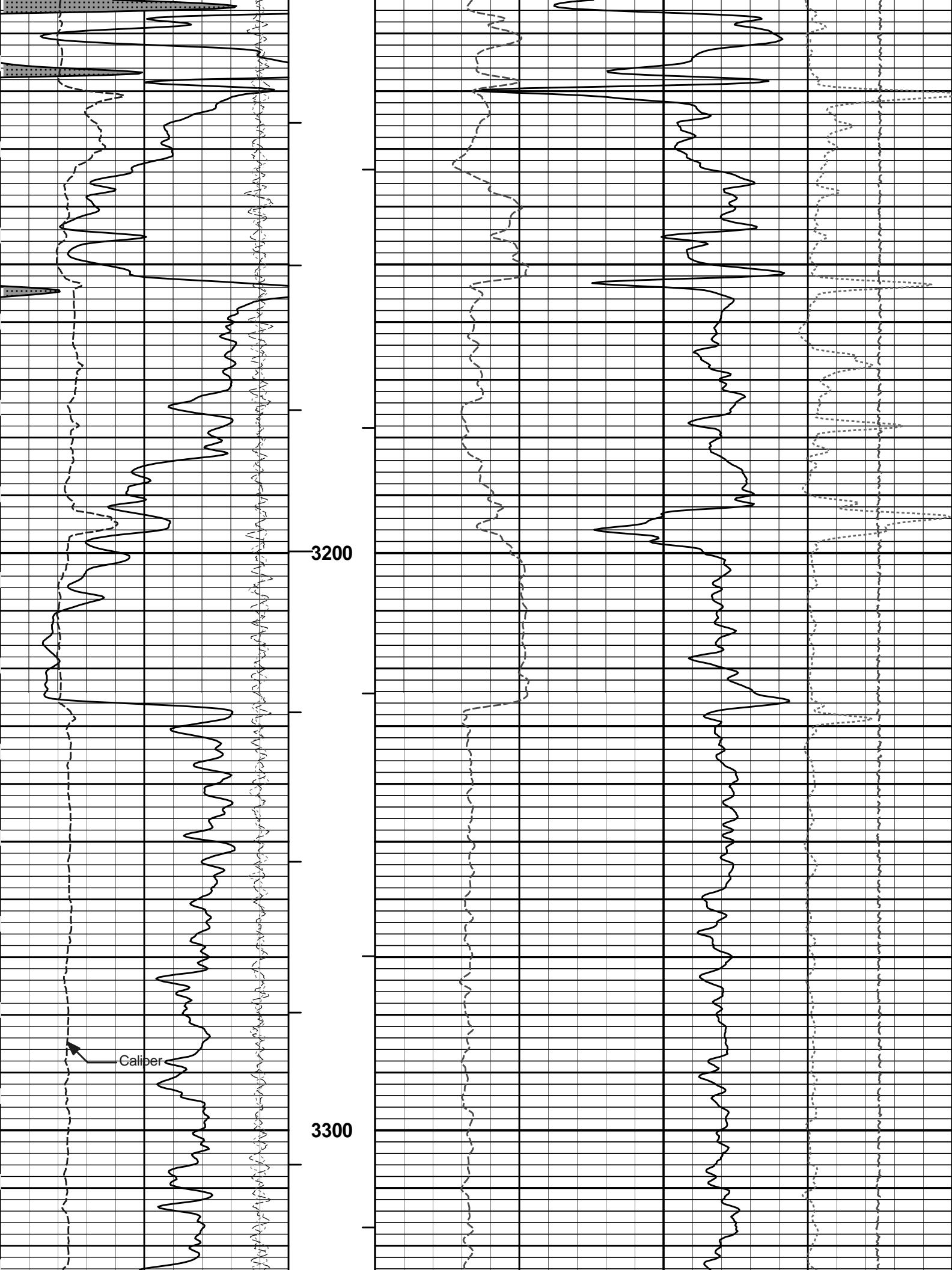

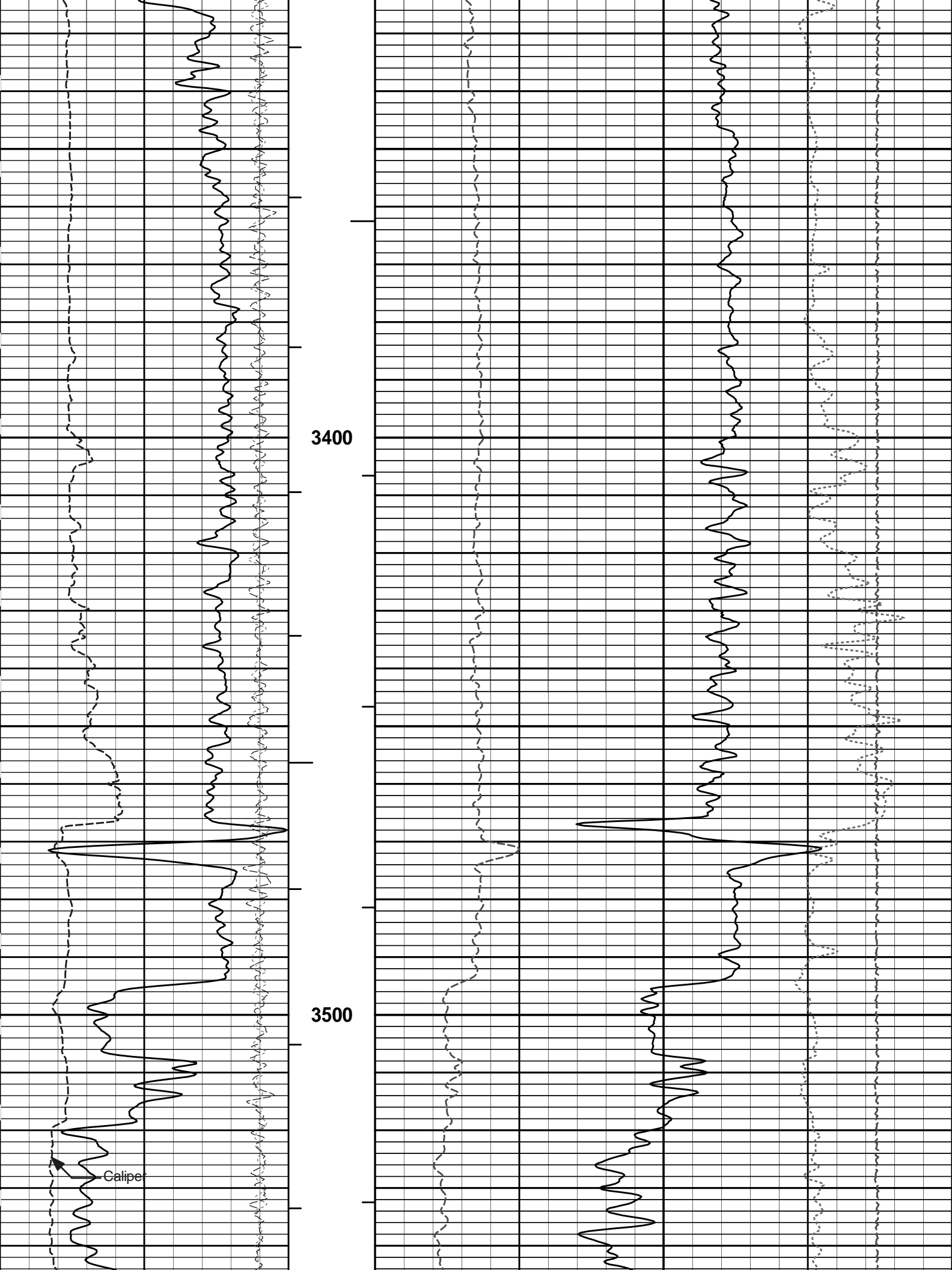

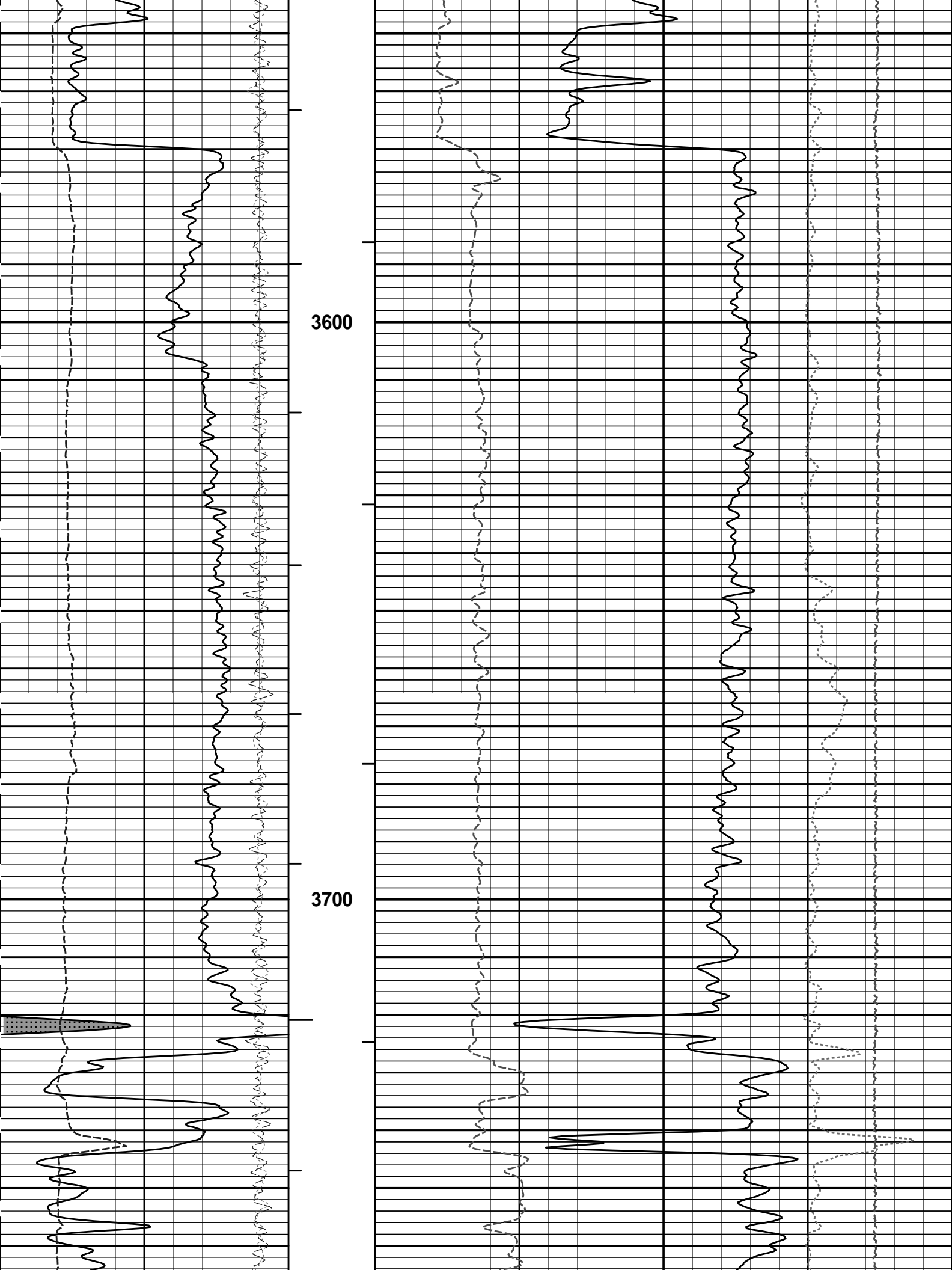

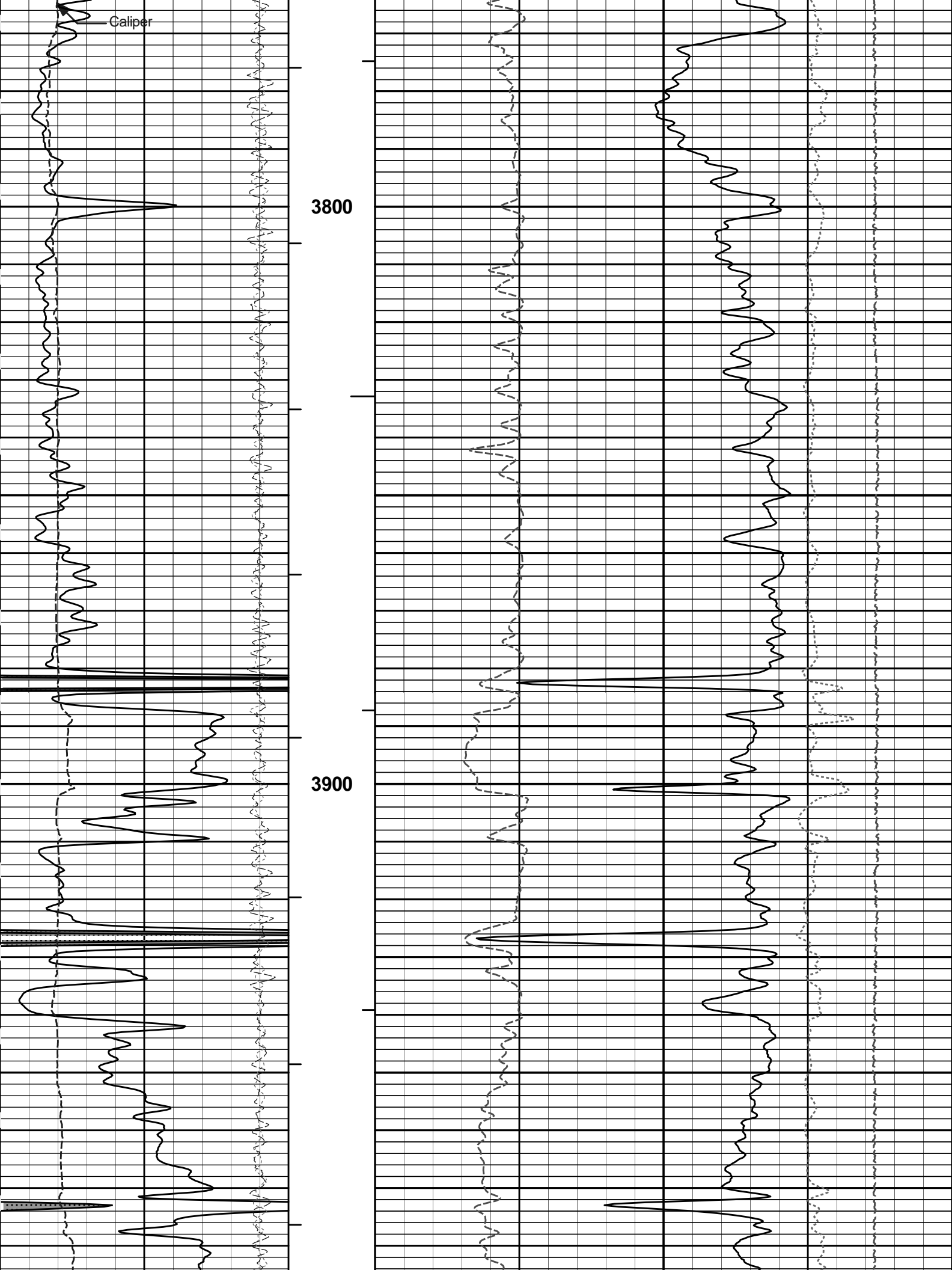

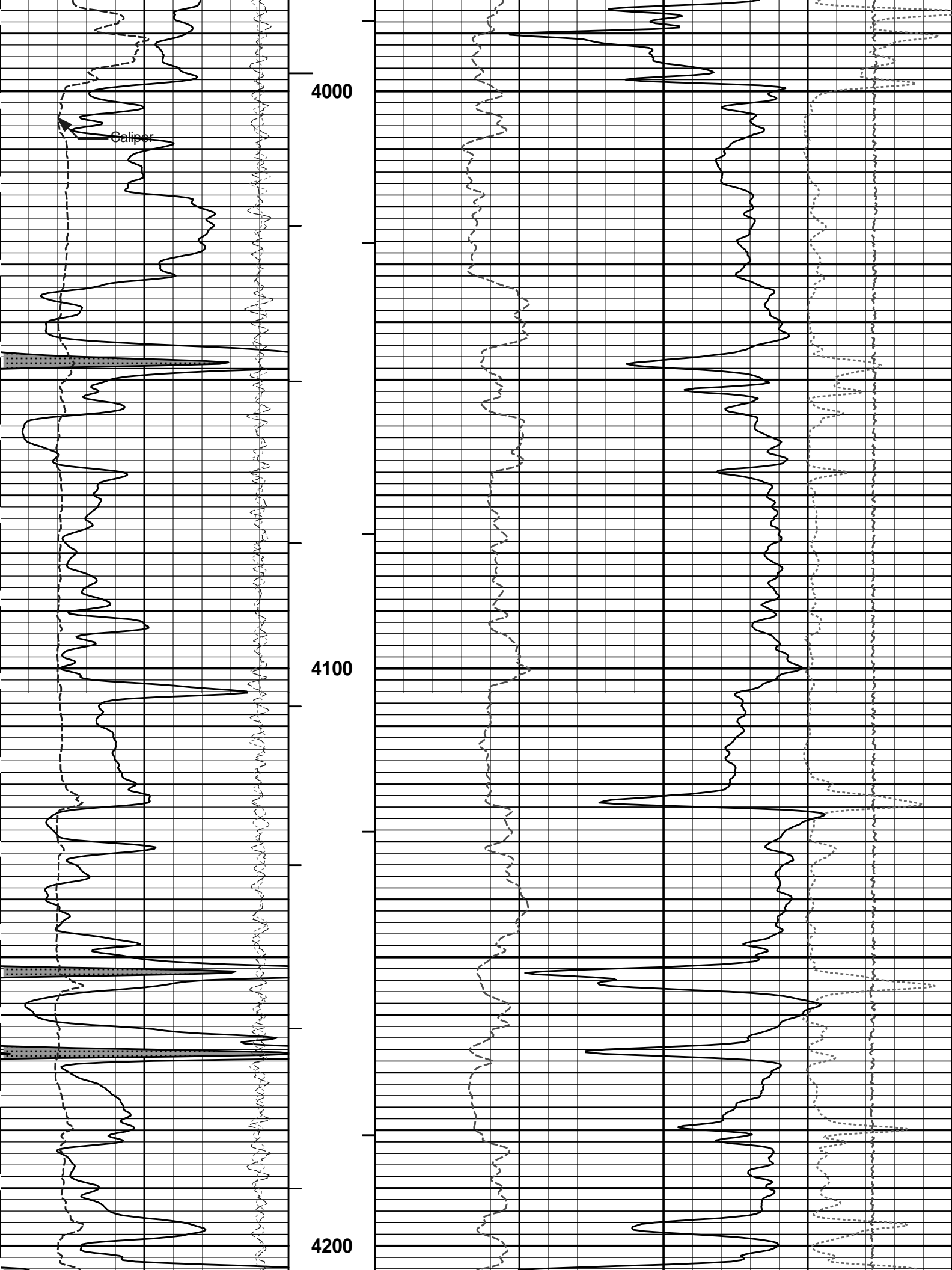

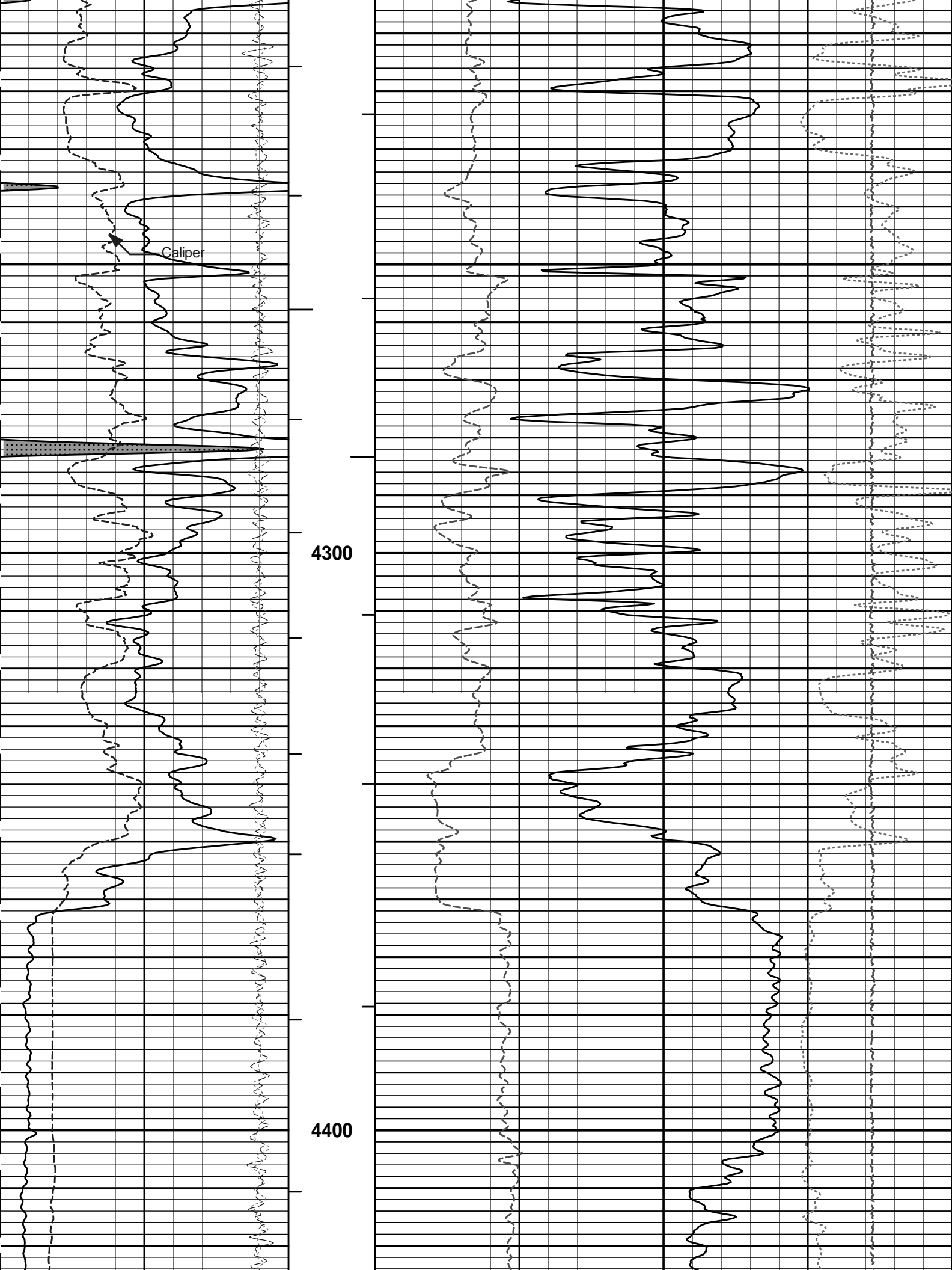

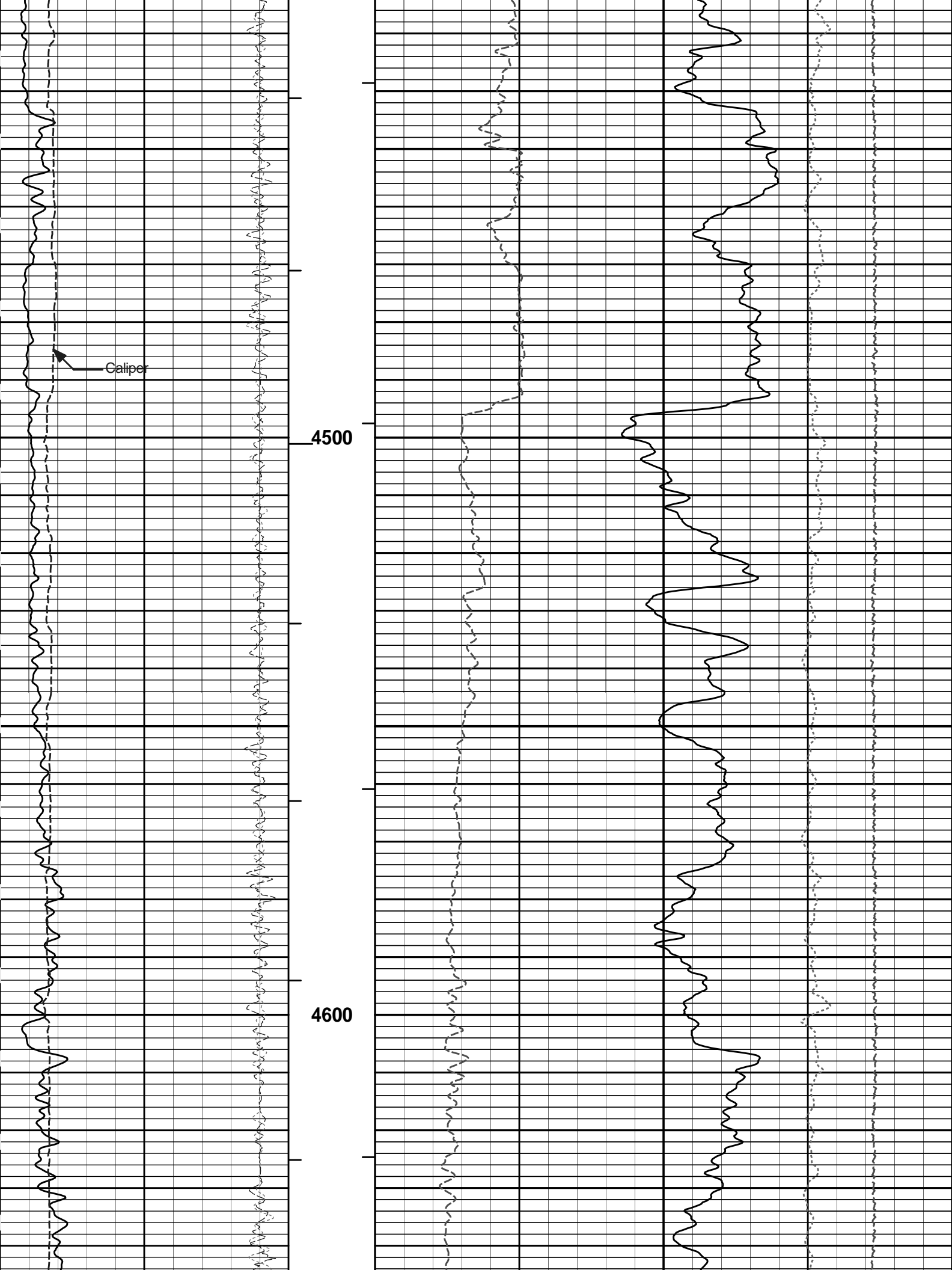

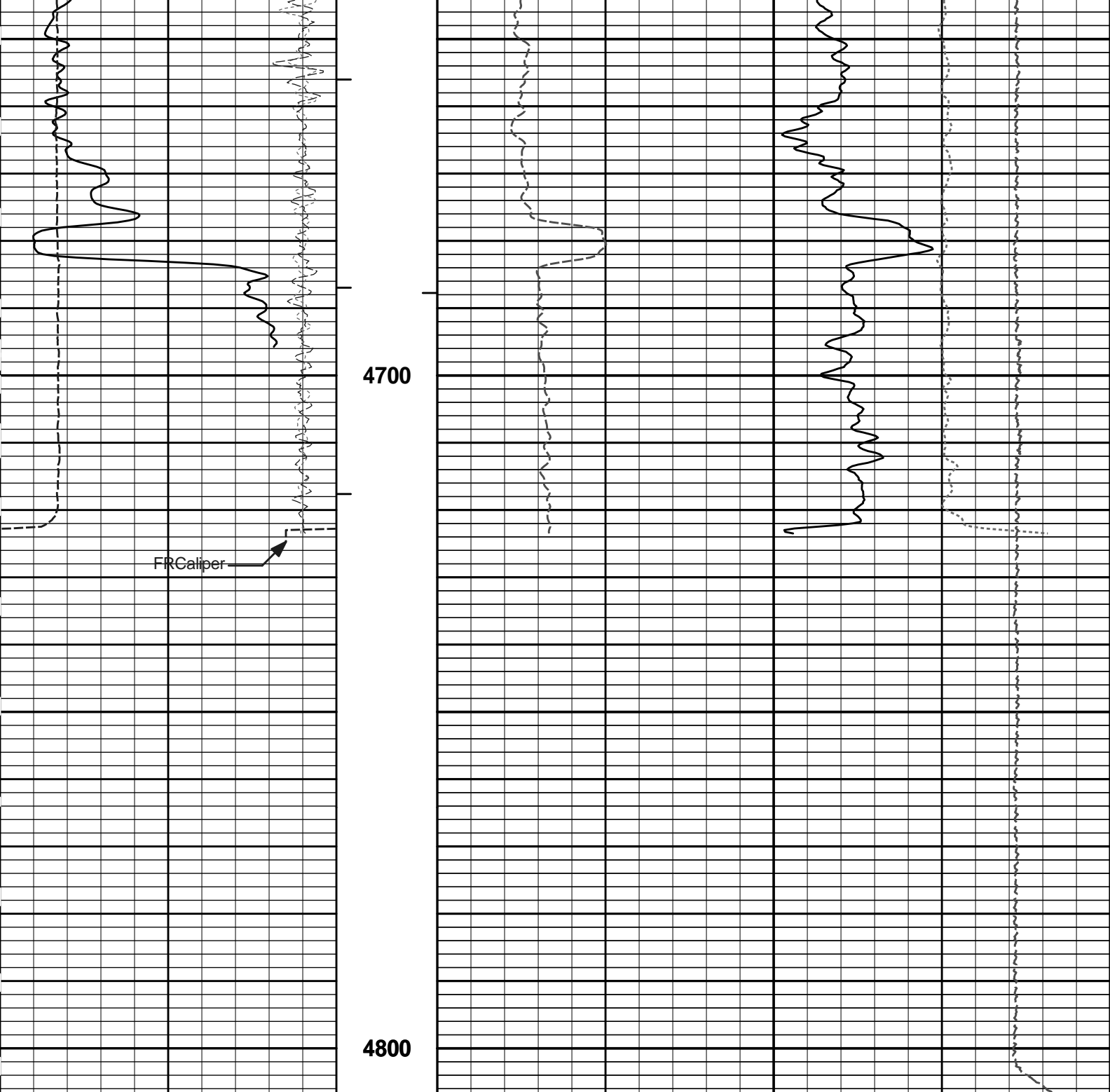

6	Caliper	16	MD	0	10	-0.25	DensityCorr	0.25
	inches		1 : 240				g/cc	
-18	NearQuality	2	AHV		15K		Tension	0
			ft3				pounds	
18	FarQuality	-2	BHV	2	Bulk Density			3
			ft3		g/cc			
0	Gamma Ray	150						
	api							
	SHALE							

5 INCH MAIN LOG

HALLIBURTON

Plot Time: 18-Jul-13 00:58:21
 Plot Range: 4500 ft to 4807.92 ft
 Data: FLINN_A_3306\Well Based\REPEAT\
 Plot File: \\LOCAL\FLINN_A_3306\0001 SP-GTET-CSNG-DSN-SDL-FLEX-IDT-ICT-WAVE-ACRT-CHIPORO\BULKD_5_REP_LIB

REPEAT SECTION

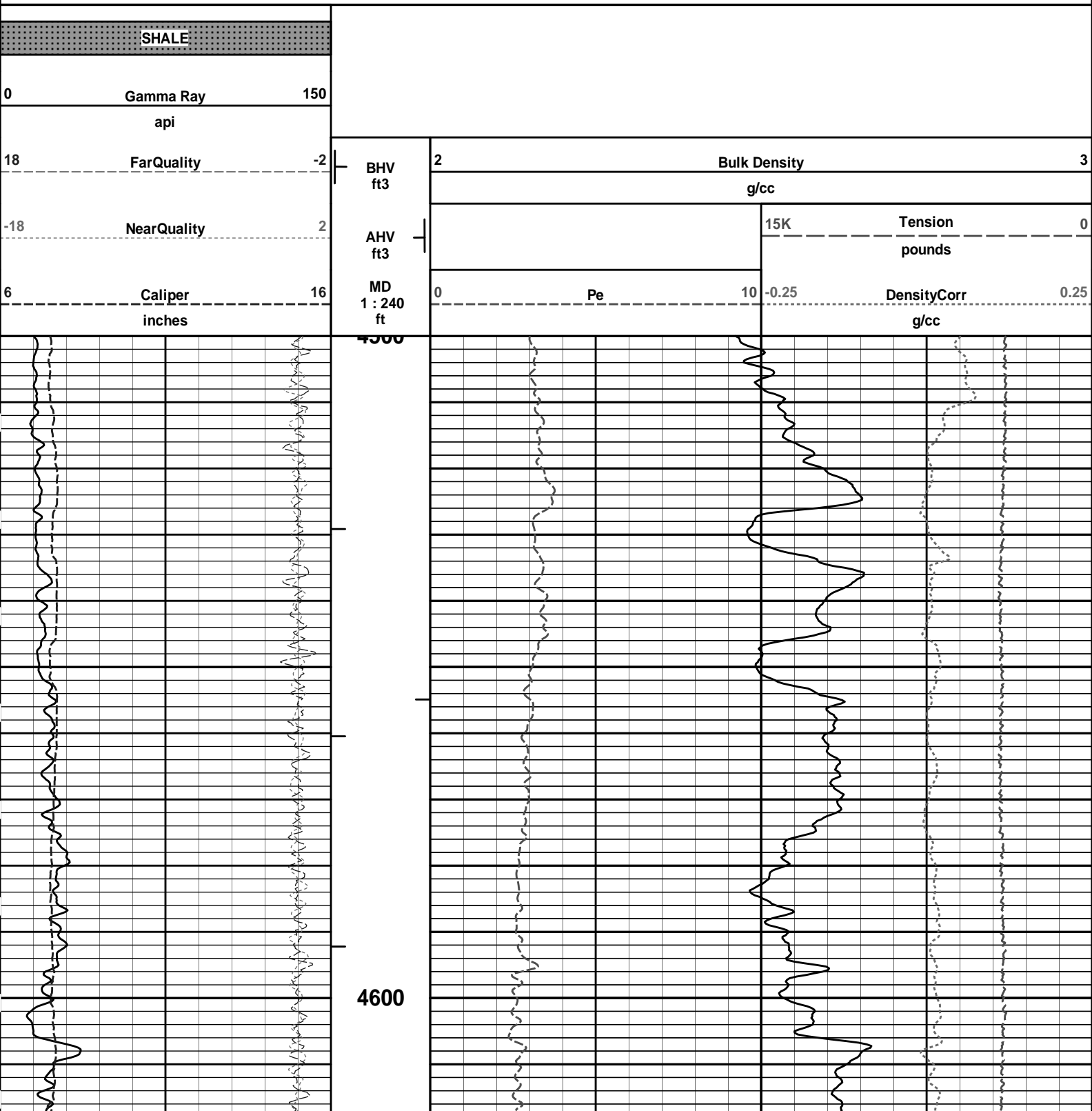

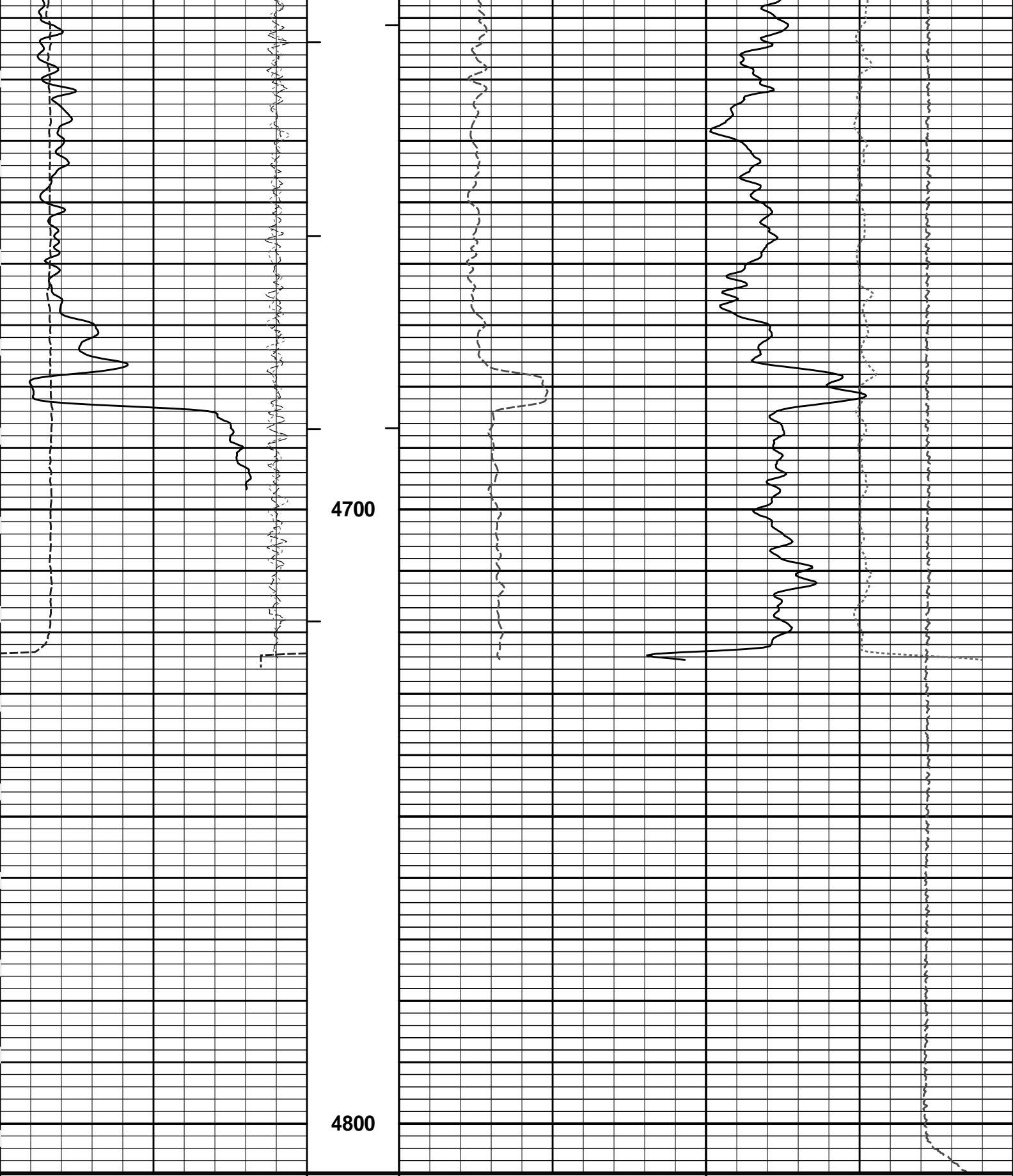

4700

4800

6	Caliper	16	MD	0	10	-0.25	DensityCorr	0.25
	inches		1 : 240				g/cc	
-18	NearQuality	2	AHV		15K		Tension	0
			ft3				pounds	
18	FarQuality	-2	BHV	2	Bulk Density			3
			ft3		g/cc			

SDLT-10685803
360.00 lbs

SDLT Pad-10673790
65.00 lbs
Microlog Pad-10685803
8.00 lbs

Ø 4.500 in →

Ø 4.750 in* →
Ø 4.750 in* →

Microlog @ 82.98 ft
SDL Caliper @ 82.80 ft
SDL @ 82.79 ft

10.81 ft

79.98 ft

IQ Flex-10000954
140.00 lbs

Ø 3.625 in →

5.67 ft

74.31 ft

IDT-1094
150.00 lbs

Ø 3.625 in →

7.58 ft

66.73 ft

ICT-10880633
330.00 lbs

Ø 3.625 in →

12.83 ft

ICT Caliper @ 56.69 ft

53.90 ft

Wavesonic-I-
10753396
520.00 lbs

Ø 3.625 in →

34.07 ft

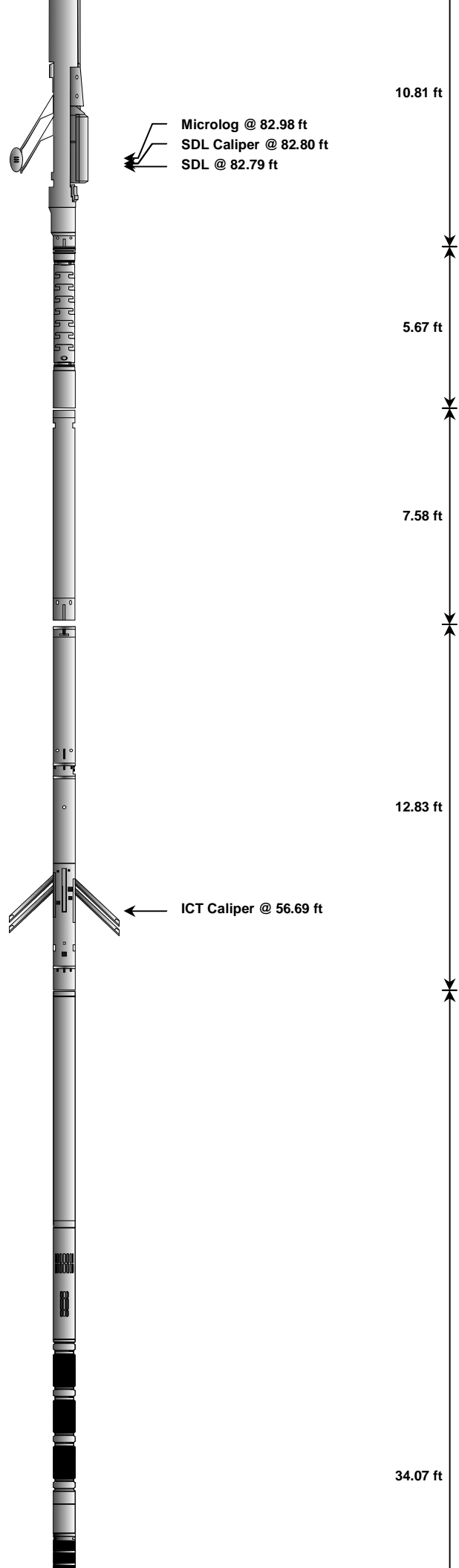

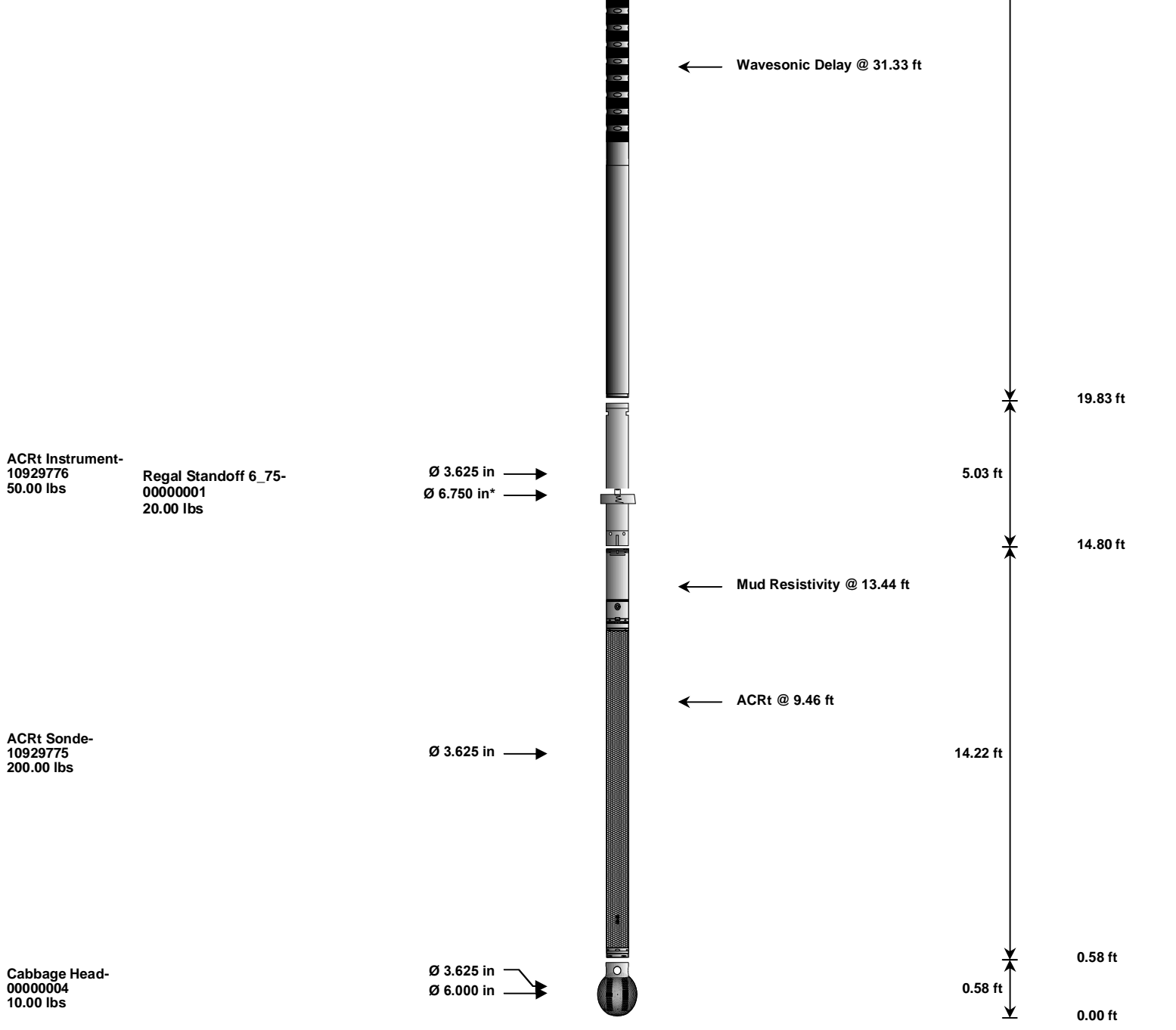

Mnemonic	Tool Name	Serial Number	Weight (lbs)	Length (ft)	Accumulated Length (ft)	Max. Log. Speed (fpm)
CH_HOS	Hostile Cable Head with Load Cell	954	37.50	3.03	120.91	300.00
SP	SP Sub	12345678	60.00	3.74	117.17	300.00
GTET	Gamma Telemetry Tool	10811258	165.00	8.52	108.65	60.00
CSNG	Compensated Spectral Natural Gamma	10965402	114.00	8.17	100.48	15.00
UWR3P6	Universal Wear Ring 3 5-8 inch	10965402	5.00	0.35 *	104.56	300.00
DSNT	Dual Spaced Neutron	10755066	174.00	9.69	90.80	60.00
DCNT	DSN Decentralizer	10735145	6.60	5.13 *	94.13	300.00
SDLT	Spectral Density Tool	10685803	360.00	10.81	79.98	60.00
MICP	Microlog Pad	10685803	8.00	1.00 *	82.48	60.00
SDLP	Density Insite Pad	10673790	65.00	2.55 *	82.19	60.00
IQF	IQ Flex tool	10000954	140.00	5.67	74.31	300.00
IDT	Insite Directional Tool	1094	150.00	7.58	66.73	30.00
ICT	Six Independent Arm Caliper	10880633	330.00	12.83	53.90	30.00
WSTT	WaveSonic Insite	10753396	520.00	34.07	19.83	30.00
ACRt	Array Compensated True Resistivity Instrument Section	10929776	50.00	5.03	14.80	300.00
RSOF	Regal Standoff 6.75in	00000001	20.00	0.52 *	16.33	300.00
ACRt	Array Compensated True Resistivity Sonde Section	10929775	200.00	14.22	0.58	300.00
CBHD	Cabbage Head	00000004	10.00	0.58	0.00	300.00
Total			2,415.10	123.94		

* Not included in Total Length and Length Accumulation.

HALLIBURTON**CALIBRATION REPORT****NATURAL GAMMA RAY TOOL SHOP CALIBRATION**

Tool Name: GTET - 10811258 **Reference Calibration Date:** 05-Jun-13 10:17:04
Engineer: S. INGERSOLL **Calibration Date:** 01-Jul-13 12:19:31
Software Version: WL INSITE R3.8.4 (Build 5) **Calibration Version:** 1

Calibrator Source S/N: TB-185

Calibrator API Reference:228.00 api

Equivalent Calibrator API Reference:232.0 api

Measurement	Measured	Calibrated	Units
Background	35.8	34.7	api
Background + Calibrator	274.6	266.7	api
Calibrator	238.8	232.0	api

NATURAL GAMMA RAY TOOL FIELD CALIBRATION

Tool Name: GTET - 10811258 **Reference Calibration Date:** 01-Jul-13 12:19:31
Engineer: J. BOLLLOM **Calibration Date:** 17-Jul-13 10:53:59
Software Version: WL INSITE R3.8.4 (Build 5) **Calibration Version:** 1

Calibrator Source S/N: TB-185

Calibrator API Reference:228.00 api

Equivalent Calibrator API Reference:232.0 api

Field Verification	Shop	Field	Units
Background	34.7	41.7	api
Background + Calibrator	266.7	268.2	api
Calibrator	232.0	226.6	api

Shop	Field	Difference	Tolerance
232.0	226.6	5.4	+/- 9.00

DUAL SPACED NEUTRON SHOP CALIBRATION

Tool Name: DSNT - 10755066 **Reference Calibration Date:** 19-May-13 13:08:19
Engineer: S. INGERSOLL **Calibration Date:** 01-Jul-13 16:27:31
Software Version: WL INSITE R3.8.4 (Build 5) **Calibration Version:** 1

Logging Source S/N: DSN-436

Tank Serial Number: 105060

Reference value assigned to Tank: 51.680

Snow Block S/N: 08910

Calibration Tank Water Temperature: 62 degF

Min. Tool Housing Outside Diameter: 3.620 in

CALIBRATION CONSTANTS

Measurement	Prev. Value	New Value	Control Limit On New Value
Gain:	0.953	0.952	0.900 - 1.100

WATER TANK SUMMARY (Horizontal Water Tank)

Measurement	Current Reading (Previous Coef.)	Calibrated (New Coef.)	Change	Control Limit On Change
Porosity (decp):	0.2110	0.2106	0.0003	+/- 0.0020
Calibrated Ratio:	9.73	9.72	0.011	+/- 0.050

VERIFIER		
Measurement	Value	Control Limit
Snow-Block Porosity (decp):	0.0662	0.02000 - 0.09000

PASS/FAIL SUMMARY	
Background Check:	Passed
Gain-Range Check:	Passed
Snow-Block Check:	Passed

DUAL SPACED NEUTRON FIELD CALIBRATION

Tool Name: DSNT - 10755066	Reference Calibration Date: 01-Jul-13 16:27:31
Engineer: J. BOLLUM	Calibration Date: 17-Jul-13 11:02:02
Software Version: WL INSITE R3.8.4 (Build 5)	Calibration Version: 1

Logging Source S/N: DSN-436
Snow Block S/N: 08910

NEUTRON FIELD-CHECK SUMMARY				
	Shop	Field	Difference	Control Limit On Change
Snow-Block Porosity (decp):	0.0662	0.0642	-0.0019	+/- 0.0150

PASS/FAIL SUMMARY	
Block Change Check:	Passed
Snow Block Stat Check:	Passed
Temperature Check:	Passed

DENSITY CALIPER SHOP CALIBRATION

Tool Name: SDLT - 10685803	Reference Calibration Date: 20-Jun-13 16:09:36
Engineer: S. INGERSOLL	Calibration Date: 01-Jul-13 15:30:20
Software Version: WL INSITE R3.8.4 (Build 5)	Calibration Version: 1
Host Tool Name: DSNT - 10755066	

CALIBRATION COEFFICIENTS			
Measurement	Previous Value	New Value	Control Limit On New Value
Pad Offset	-4578.27	-4092.36	-7000.00 - -1000.00
Pad Gain	0.0003895	0.0003815	0.000200 - 0.000600
Arm Offset	-2279.74	-2703.47	-5000.00 - 3000.00
Arm Gain	0.0004915	0.0005069	0.000300 - 0.000700
Arm Power	-0.000003324	-0.000004137	-0.000010000 - 0.000010000

The ring diameter is computed from: $\text{DIAMETER} = \text{PAD EXTENSION} + \text{ARM EXTENSION} + \text{TOOL DIAMETER}$
Tool Diameter: 4.50 in

CALIBRATION RINGS				
Measurement	Current Reading (Previous Coeff.)	Calibrated (New Coeff.)	Change	Control Limit On New Value
PAD EXTENSION:				
Small Ring (in)	1.85	2.00	0.15	+/- 0.20
Medium Ring (in)	3.64	3.75	0.11	+/- 0.20
RING DIAMETER:				
Small Ring (in)	6.47	6.50	0.03	+/- 0.20

Small Ring (in)	0.47	0.50	0.03	+/- 0.20
Medium Ring (in)	8.18	8.25	0.07	+/- 0.20
Large Ring (in)	14.88	15.00	0.12	+/- 0.20

PASS/FAIL SUMMARY

Calibration-Coefficients Range Check:	Passed
Ring-Measurement Check:	Passed

PASS/FAIL SUMMARY

Calibration-Coefficients Range Check:	Passed
---------------------------------------	--------

SDLT CALIPER FIELD CALIBRATION

Tool Name: SDLT - 10685803	Reference Calibration Date: 01-Jul-13 15:30:20
Engineer: J. BOLLLOM	Calibration Date: 17-Jul-13 10:55:28
Software Version: WL INSITE R3.8.4 (Build 5)	Calibration Version: 1

MEASURED CALIPER VALUES

Measurement	Shop	Field	Change	Control Limit On New Value
Pad Extension	3.75	3.78	0.03	+/- 0.10
Ring Diameter	8.25	8.27	0.02	+/- 0.15

PASS/FAIL SUMMARY

Pad Extension Check:	Passed
Diameter Check:	Passed

SPECTRAL DENSITY SHOP CALIBRATION

Tool Name: SDLT Pad - 10673790	Reference Calibration Date: 18-May-13 21:41:33
Engineer: S. INGERSOLL	Calibration Date: 01-Jul-13 12:50:36
Software Version: WL INSITE R3.8.4 (Build 5)	Calibration Version: 1

Logging Source S/N: 5073GW		
Aluminum Block S/N: LIBERAL ALUMINUM	Density: 2.598g/cc	Pe: 3.170
Magnesium Block S/N: LIBERAL MAG BLOCK	Density: 1.684g/cc	Pe: 2.598

DENSITY CALIBRATION SUMMARY

Measurement	Previous Value	New Value	Control Limit
Near Bar Gain	1.0467	1.0402	0.90 - 1.10
Near Dens Gain	1.0386	1.0308	0.90 - 1.10
Near Peak Gain	1.0598	1.0600	0.90 - 1.10
Near Lith Gain	1.0491	1.0179	0.90 - 1.10
Far Bar Gain	1.0107	1.0098	0.90 - 1.10
Far Dens Gain	0.9993	0.9981	0.90 - 1.10
Far Peak Gain	0.9920	0.9920	0.90 - 1.10
Far Lith Gain	0.9604	0.9603	0.90 - 1.10
Near Bar Offset	-0.1729	-0.1107	NONE
Near Dens Offset	-0.0887	-0.0193	NONE
Near Peak Offset	-0.2382	-0.2385	NONE
Near Lith Offset	-0.1653	0.0962	NONE
Far Bar Offset	0.0790	0.0820	NONE
Far Dens Offset	0.1500	0.1581	NONE
Far Peak Offset	0.1726	0.1658	NONE
Far Lith Offset	0.3450	0.3403	NONE
Near Bar Background	864.83	861.54	700 - 1450

Near Dens Background	283.75	282.76	230 - 480
Near Peak Background	124.36	123.64	100 - 210
Near Lith Background	152.79	154.08	125 - 260
Far Bar Background	576.79	576.20	450 - 900
Far Dens Background	226.46	226.25	175 - 345
Far Peak Background	90.61	89.12	70 - 140
Far Lith Background	93.93	93.55	75 - 145

CALIBRATION BLOCK SUMMARY				
Measurement	Current Reading (Previous Coef)	Calibrated (New Coef)	Change	Control Limit On Change
MAGNESIUM				
Density (g/cc)	1.679	1.684	0.005	+/- 0.015
Pe	2.554	2.562	0.008	+/- 0.150
ALUMINUM				
Density (g/cc)	2.591	2.598	0.007	+/- 0.01500
Pe	3.154	3.131	-0.023	+/- 0.150

TOOL SUMMARY				
Measurement	Near Detector		Far Detector	
	Value	Control Limits	Value	Control Limits
QUALITY				
Background	0.0002	+/- 0.0110	-0.0002	+/- 0.0140
Magnesium Block	-0.0001	+/- 0.0110	0.0009	+/- 0.0140
Aluminum Block	0.0002	+/- 0.0110	0.0013	+/- 0.0140
Resolution	8.58	6.00 - 11.50	8.79	6.00 - 11.50
Internal Verifier(B+D+P+L)	1422	1200 - 2700	985	800 - 1700

PASS/FAIL SUMMARY	
Background Quality Check:	Passed
Background Range Check:	Passed
Background Resolution Check:	Passed
Background Verification Check:	Passed
Magnesium Quality Check:	Passed
Aluminum Quality Check:	Passed
Gains Check:	Passed
Changes in Calibration Blocks:	Passed

SPECTRAL DENSITY FIELD CHECK			
Tool Name:	SDLT Pad - 10673790	Reference Calibration Date:	01-Jul-13 12:50:36
Engineer:	J. BOLLLOM	Calibration Date:	17-Jul-13 10:53:04
Software Version:	WL INSITE R3.8.4 (Build 5)	Calibration Version:	1

Pad Temperature: 75.2 degF

DENSITY FIELD CALIBRATION SUMMARY				
Measurement	Shop	Field	Change	Control Limit +/-
Near (B+D+P+L) cps	1422.026	1419.391	-2.635	15.221
Far (B+D+P+L) cps	985.123	983.676	-1.447	16.837
Near Resolution	8.58	8.66	0.080	0.50
Far Resolution	8.79	8.95	0.160	1.00

PASS/FAIL SUMMARY	
-------------------	--

Bkg Quality Check:	Passed
Bkg Resolution Check:	Passed
Bkg Verification Check:	Passed

CALIBRATION SUMMARY

Sensor	Shop	Field	Post	Difference	Tolerance	Units
GTET-10811258						
Gamma Ray Calibrator	232.0	226.6	-----	5.4	+/- 9.00	api
DSNT-10755066						
Snow-Block Porosity	0.0662	0.0642	-----	0.0020	+/- 0.0150	decp
SDLT-10685803						
Pad Extension	3.75	3.78	-----	-0.03	+/-0.10	in
Ring Diameter	8.25	8.27	-----	-0.02	+/-0.15	in
SDLT Pad-10673790						
Near(B+D+P+L)	1422.026	1419.391	-----	2.635	+/-15.221	cps
Far(B+D+P+L)	985.123	983.676	-----	1.447	+/-16.837	cps

Data: FLINN A 3306\0001 SP-GTET-CSNG-DSN-SDL-FLEX-IDT-ICT-WAVE-ACRT-CH\IDLE

Date: 17-Jul-13 20:42:24

HALLIBURTON

PARAMETERS REPORT

Depth (ft)	Tool Name	Mnemonic	Description	Value	Units
TOP					
	SHARED	BS	Bit Size	7.875	in
	SHARED	UBS	Use Bit Size instead of Caliper for all applications.	No	
	SHARED	MDBS	Mud Base	Water	
	SHARED	MDWT	Borehole Fluid Weight	9.200	ppg
	SHARED	WAGT	Weighting Agent	Natural	
	SHARED	BSAL	Borehole salinity	0.00	ppm
	SHARED	FSAL	Formation Salinity NaCl	0.00	ppm
	SHARED	KPCT	Percent K in Mud by Weight?	0.00	%
	SHARED	RMUD	Mud Resistivity	2.000	ohmm
	SHARED	TRM	Temperature of Mud	75.0	degF
	SHARED	CSD	Logging Interval is Cased?	No	
	SHARED	ICOD	AHV Casing OD	5.500	in
	SHARED	ST	Surface Temperature	75.0	degF
	SHARED	TD	Total Well Depth	4800.00	ft
	SHARED	BHT	Bottom Hole Temperature	200.0	degF
	SHARED	SVTM	Navigation and Survey Master Tool	IDT	
	SHARED	AZTM	High Res Z Accelerometer Master Tool	IDT	
	SHARED	TEMM	Temperature Master Tool	NONE	
	SHARED	BHSM	Borehole Size Master Tool	ICT	
	Rwa / CrossPlot	XPOK	Process Crossplot?	Yes	
	Rwa / CrossPlot	FCHO	Select Source of F	Automatic	
	Rwa / CrossPlot	AFAC	Archie A factor	0.6200	
	Rwa / CrossPlot	MFAC	Archie M factor	2.1500	
	Rwa / CrossPlot	RMFR	Rmf Reference	0.10	ohmm
	Rwa / CrossPlot	TMFR	Rmf Ref Temp	75.00	degF
	Rwa / CrossPlot	RWA	Resistivity of Formation Water	0.05	ohmm

Rwa / CrossPlot	ADP	Use Air Porosity to calculate CrossplotPhi	No	
GTET	GROK	Process Gamma Ray?	Yes	
GTET	GRSO	Gamma Tool Standoff	0.000	in
GTET	GEOK	Process Gamma Ray EVR?	No	
GTET	TPOS	Tool Position for Gamma Ray Tools.	Eccentered	
CSNG	CGOK	Process CSNG Data?	Yes	
CSNG	CENT	Is Tool Centralized?	No	
CSNG	GBOK	Gamma Enviromental Corrections?	Yes	
CSNG	BARF	Barite Correction Factor	1.00	
CSNG	ORDG	Use Fixed Gain	No	
CSNG	ORDO	Use Fixed Offset	No	
CSNG	ORDR	Use Fixed Resolution Degradation Factor	No	
DSNT	DNOK	Process DSN?	Yes	
DSNT	DEOK	Process DSN EVR?	No	
DSNT	NLIT	Neutron Lithology	Limestone	
DSNT	DNSO	DSN Standoff - 0.25 in (6.35 mm) Recommended	0.250	in
DSNT	DNTP	Temperature Correction Type	None	
DSNT	DPRS	DSN Pressure Correction Type	None	
DSNT	SHCO	View More Correction Options	No	
DSNT	UTVD	Use TVD for Gradient Corrections?	No	
DSNT	LHWT	Logging Horizontal Water Tank?	No	
SDLT	CLOK	Process Caliper Outputs?	Yes	
SDLT Pad	DNOK	Process Density?	Yes	
SDLT Pad	DNOK	Process Density EVR?	No	
SDLT Pad	CB	Logging Calibration Blocks?	No	
SDLT Pad	SPVT	SDLT Pad Temperature Valid?	Yes	
SDLT Pad	DTWN	Disable temperature warning	No	
SDLT Pad	DMA	Formation Density Matrix	2.710	g/cc
SDLT Pad	DFL	Formation Density Fluid	1.000	g/cc
Microlog Pad	MLOK	Process MicroLog Outputs?	Yes	
IDT	WRTI	Survey Writing Interval	30	ft
IDT	SOPT	Smoothing Option	None	
ICT	CLOK	Process Caliper Outputs?	Yes	
ICT	DARM	Disable Caliper Arm	No	
ICT	ATDS	Arm To Disable	0	
ICT	REPM	Method to replace arm?	Caliper Average	
ICT	ARMV	Diameter to use for disabled arm	0.00	in
ICT	DARM	Disable Second Caliper Arm	No	
ICT	ATDS	Second Arm To Disable	0	
ICT	REPM	Method to replace second arm?	Caliper Average	
ICT	ARMV	Diameter to use for second disabled arm	0.00	in
ICT	NAVS	Navigation Source Tool	IDT	
ICT	CL10	Radius 1 Offset	0.0	in
ICT	CL20	Radius 2 Offset	0.0	in
ICT	CL30	Radius 3 Offset	0.0	in
ICT	CL40	Radius 4 Offset	0.0	in
ICT	CL50	Radius 5 Offset	0.0	in
ICT	CL60	Radius 6 Offset	0.0	in
ICT	BHVC	Radius type for borehole volume calcuations	Elliptical	
Wavesonic-I	WSOK	Process WSTT?	Yes	
Wavesonic-I	AFIL	Adaptive Filtering?	No	
Wavesonic-I	PINT	Process 1 Sample and Skip	0	
Wavesonic-I	PROM	Process Mode: M=1,MX=2,MY=3,MXY=4	4	
Wavesonic-I	DTSH	Delta -T Shale	100.00	uspf
Wavesonic-I	DTMT	Delta -T Matrix T	0.00	uspf

Wavesonic-I	DTM	Delta -T Matrix Type	User define	47.60	uspf
Wavesonic-I	DTMA	Delta -T Matrix		47.60	uspf
Wavesonic-I	DTFL	Delta -T Fluid		189.00	uspf
Wavesonic-I	RHOM	Matrix Density		2.7100	g/cc
Wavesonic-I	RHOF	Fluid Density		1.0000	g/cc
Wavesonic-I	SMTH	Semblance Threshold		0.25	
Wavesonic-I	VPVS	VPVS Ratio for Porosity		1.40	
Wavesonic-I	APEQ	Acoustic Porosity Equation		Wylie	
Wavesonic-I	NAVS	Navigation Source Tool		IDT	
ACRt Sonde	RTOK	Process ACRt?		Yes	
ACRt Sonde	MNSO	Minimum Tool Standoff		1.50	in
ACRt Sonde	TCS1	Temperature Correction Source	FP Lwr & FP Upr		
ACRt Sonde	TPOS	Tool Position	Free Hanging		
ACRt Sonde	RMOP	Rmud Source	Mud Cell		
ACRt Sonde	RMIN	Minimum Resistivity for MAP		0.20	ohmm
ACRt Sonde	RMIN	Maximum Resistivity for MAP		200.00	ohmm
ACRt Sonde	THQY	Threshold Quality		0.50	
ACRt Sonde	MRFX	Fixed mud resistivity		2000	ohmm

BOTTOM

Data: FLINN_A_3306I0001 SP-GTET-CSNG-DSN-SDL-FLEX-IDT-ICT-WAVE-ACRT-CHIDL

Date: 17-Jul-13 20:37:45

HALLIBURTON

INPUTS, DELAYS AND FILTERS TABLE

Mnemonic	Input Description	Delay (ft)	Filter Type	Filter Length (ft)
Depth Panel				
TENS	Tension	0.00	NO	
CH_HOS				
DHTN	DownholeTension	0.00	BLK	0.000
SP Sub				
PLTC	Plot Control Mask	119.13	NO	
SP	Spontaneous Potential	119.13	BLK	1.250
SPR	Raw Spontaneous Potential	119.13	NO	
SPO	Spontaneous Potential Offset	119.13	NO	
GTET				
TPUL	Tension Pull	111.11	NO	
GR	Natural Gamma Ray API	111.11	TRI	1.750
GRU	Unfiltered Natural Gamma Ray API	111.11	NO	
EGR	Natural Gamma Ray API with Enhanced Vertical Resolution	111.11	W	1.416 , 0.750
ACCZ	Accelerometer Z	0.00	BLK	0.083
DEVI	Inclination	0.00	NO	
CSNG				
TPUL	Tension Pull	103.02	NO	
STAT	Status	103.02	NO	
FRMC	Tool Frame Count	103.02	BLK	0.250
TFRM	Total Frames	103.02	NO	
LSPD	Line Speed	103.02	BLK	0.250
CTIM	Accumulation time for sample	103.02	BLK	0.250
NOIS	Spectral Noise	103.02	BLK	0.250
STAB	Stabilizer Voltage in mv	103.02	BLK	0.250

STAB	Stabilizer Voltage in mV	103.02	BLK	0.250
STBP	Stabilizer 60 KEV Peak	103.02	BLK	0.250
AMER	Americium	103.02	BLK	0.250
FTMP	Flask PCB Temperature	103.02	BLK	0.250
SPEL	Low Energy Spectrum	103.02	BLK	0.250
SPEH	High Energy Spectrum	103.02	BLK	0.250
SSP	Stabilization Energy Spectrum	103.02	BLK	0.250
CSPC	CSNG Lo Hi Spectrum Data	103.02	NO	
DSNT				
TPUL	Tension Pull	92.70	NO	
RNDS	Near Detector Telemetry Counts	92.80	BLK	1.417
RFDS	Far Detector Telemetry Counts	93.55	TRI	0.583
DNTT	DSN Tool Temperature	92.80	NO	
DSNS	DSN Tool Status	92.70	NO	
ERND	Near Detector Telemetry Counts EVR	92.80	BLK	0.000
ERFD	Far Detector Telemetry Counts EVR	93.55	BLK	0.000
ENTM	DSN Tool Temperature EVR	92.80	NO	
SDLT				
TPUL	Tension Pull	82.80	NO	
PCAL	Pad Caliper	82.80	TRI	0.250
ACAL	Arm Caliper	82.80	TRI	0.250
IDT				
TPUL	Tension Pull	67.73	NO	
ACCX	Accelerometer X	67.73	NO	
ACCY	Accelerometer Y	67.73	NO	
ACCZ	Accelerometer Z	67.73	NO	
MAGX	magnetometer x with unit	67.73	NO	
MAGY	Magnetometer Y with unit	67.73	NO	
MAGZ	magnetometer z with unit	67.73	NO	
IAMP	Accelerometer Temperature	67.73	NO	
MTMP	Magnetometer Temperature	67.73	NO	
ICT				
TPUL	Tension Pull	56.69	NO	
	Arm Potentiometer excitation V	53.90	NO	
	Caliper 1 measurement	56.69	BLK	1.250
	Caliper 2 measurement	56.69	BLK	1.250
	Caliper 3 measurement	56.69	BLK	1.250
	Caliper 4 measurement	56.69	BLK	1.250
	Caliper 5 measurement	56.69	BLK	1.250
	Caliper 6 measurement	56.69	BLK	1.250
	Caliper Global measurement	56.69	BLK	1.250
MOTI	Motor Current	53.90	NO	
MOT1	Motor Voltage Monitor 1	53.90	NO	
STA1	Status word #1	53.90	NO	
STA2	Status word #2	53.90	NO	
PRES	Caliper percentage of total compression of the spring	53.90	NO	
HAZI	Hole Azimuth	56.69	NO	
RB	Relative Bearing	56.69	NO	
AZI1	PAD1 Azimuth	56.69	NO	
DEVI	Inclination	56.69	NO	
Wavesonic-I				
TPUL	Tension Pull	94.99	NO	

TPUL	Tension Pull	31.33	NO
DPSX	Dipole Source X Structure1	19.83	NO
DPSY	Dipole Source Y Structure1	19.83	NO
DPSM	Monopole Source Structure	19.83	NO
WVST	Wavesonic Compressed Data	31.33	NO
TPUL	Tension Pull	31.33	NO
XMS1	Wave Sonic Status Word 1	19.83	NO
XMS2	Wave Sonic Status Word 2	19.83	NO
XMS1	Wave Sonic XMITStatus Word 1	19.83	NO
XMS1	Wave Sonic XMITStatus Word 2	19.83	NO
F1HA	Dipole 1 HV After	19.83	NO
F1HB	Dipole 1 HV Before	19.83	NO
F2HA	Dipole 2 HV After	19.83	NO
F2HB	Dipole 2 HV Before	19.83	NO
F3HA	Monopole HV After	19.83	NO
F3HB	Monopole HV Before	19.83	NO
INVT	Input Voltage	19.83	NO
5VOL	5 Volts	19.83	NO
MI5A	Minus 5 Volts Analog	19.83	NO
ITMP	Instrument Temperature	19.83	NO
PL5A	Plus 5 Volts Analog	19.83	NO
5VD	Plus 5 Volts Digital	19.83	NO
TCUR	Tool Current	19.83	NO
SUPV	Supply Voltage	19.83	NO
PRVT	Preregulated voltage	19.83	NO
PRVT	Pre-regulated voltage Xmter	19.83	NO
TEMP	Temperature	19.83	NO
ACQN	Acquisition Number	19.83	NO
XDP	Delay Reference	31.33	NO
MITM	MIT Mode	31.33	NO
VERS	Version	19.83	NO
D1CT	Dipole 1 Compressed Word Count	31.33	NO
D2CT	Dipole 2 Compressed Word Count	31.33	NO
MCNT	Monopole Compressed Word Count	31.33	NO
SEQN	Sequence Number	19.83	NO
FREV	Firmware Revision	19.83	NO
MSMP	Monopole Sample Rate	19.83	NO
MSMP	Dipole Sample Rate	19.83	NO
MFWF	Monopole Firing Waveform	19.83	NO
MFRQ	Monopole Frequency	19.83	NO
MDLY	Monopole Delay	19.83	NO
DXWF	Dipole X Firing Waveform	19.83	NO
XFRQ	Dipole X Frequency	19.83	NO
XDLY	Dipole X Delay	19.83	NO
DYWF	Dipole Y Firing Waveform	19.83	NO
YFRQ	Dipole Y Frequency	19.83	NO
YDLY	Dipole Y Delay	19.83	NO
DPSX	Dipole Source X Structure1	19.83	NO
DPSY	Dipole Source Y Structure1	19.83	NO
DPSM	Monopole Source Structure	19.83	NO
WVST	Wavesonic Compressed Data	31.33	NO
AUTM	Auto Mode	19.83	NO
SONM	tool mode for sonic - 0 for normal or 3 for calibration	19.83	NO
MSL	Monopole Lower Travel Time	31.33	NO
MSH	Monopole Upper Travel Time	31.33	NO
MLFC	Monopole 1 Lower Filter Bandpass Frequency Cut off	19.83	NO

MLFC	Monopole-1 Lower Filter Bandpass Frequency Cut-off	19.83	NO
MUFC	Monopole-1 Upper Filter Bandpass Frequency Cut-off	19.83	NO
DLTT	Dipole Lower Travel Time	19.83	NO
DUTT	Dipole Upper Travel Time	19.83	NO
DLFC	Dipole Lower Filter Bandpass Frequency Cut-off	19.83	NO
DUFC	Dipole Upper Filter Bandpass Frequency Cut-off	19.83	NO
MUTE	WaveSonic Mute/Enable Channels and Sides map	19.83	NO
MUTS	Mute/Enable Sides	19.83	NO
WSRB	Relative Bearing	31.33	NO
WSAZ	WSX Azimuth Pad 1	31.33	NO
TPUL	Tension Pull	31.33	NO
WMP	Summed array of Monopole for SIDES - A,B,C,D	31.33	NO
WXX	Dipole X for SIDES - A-C	31.33	NO
WYY	Dipole Y for SIDES - B-D	31.33	NO
WXY	Dipole X for SIDES - B-D	31.33	NO
WYX	Dipole Y for SIDES - A-C	31.33	NO
TPUL	Tension Pull	31.33	NO
WMA	Monopole Waveform Side A - Channel 1 to Channel 8 Receivers	31.33	NO
WMB	Monopole Waveform Side B - Channel 1 to Channel 8 Receivers	31.33	NO
WMC	Monopole Waveform Side C - Channel 1 to Channel 8 Receivers	31.33	NO
WMD	Monopole Waveform Side D - Channel 1 to Channel 8 Receivers	31.33	NO
WXA	Dipole X Waveform Side A - Channel 1 to Channel 8 Receivers	31.33	NO
WXB	Dipole X Waveform Side B - Channel 1 to Channel 8 Receivers	31.33	NO
WXC	Dipole X Waveform Side C - Channel 1 to Channel 8 Receivers	31.33	NO
WXD	Dipole X Waveform Side D - Channel 1 to Channel 8 Receivers	31.33	NO
WYA	Dipole Y Waveform Side A - Channel 1 to Channel 8 Receivers	31.33	NO
WYB	Dipole Y Waveform Side B - Channel 1 to Channel 8 Receivers	31.33	NO
WYC	Dipole Y Waveform Side C - Channel 1 to Channel 8 Receivers	31.33	NO
WYD	Dipole Y Waveform Side D - Channel 1 to Channel 8 Receivers	31.33	NO
GAR1	Gain Side A Receiver 1	19.83	NO
GAR2	Gain Side A Receiver 2	19.83	NO
GAR3	Gain Side A Receiver 3	19.83	NO
GAR4	Gain Side A Receiver 4	19.83	NO
GAR5	Gain Side A Receiver 5	19.83	NO
GAR6	Gain Side A Receiver 6	19.83	NO
GAR7	Gain Side A Receiver 7	19.83	NO
GAR8	Gain Side A Receiver 8	19.83	NO
GBR1	Gain Side B Receiver 1	19.83	NO
GBR2	Gain Side B Receiver 2	19.83	NO
GBR3	Gain Side B Receiver 3	19.83	NO
GBR4	Gain Side B Receiver 4	19.83	NO
GBR5	Gain Side B Receiver 5	19.83	NO
GBR6	Gain Side B Receiver 6	19.83	NO
GBR7	Gain Side B Receiver 7	19.83	NO
GBR8	Gain Side B Receiver 8	19.83	NO
GCR1	Gain Side C Receiver 1	19.83	NO
GCR2	Gain Side C Receiver 2	19.83	NO
GCR3	Gain Side C Receiver 3	19.83	NO
GCR4	Gain Side C Receiver 4	19.83	NO
GCR5	Gain Side C Receiver 5	19.83	NO

GCR5	Gain Side C Receiver 5	19.83	NO
GCR6	Gain Side C Receiver 6	19.83	NO
GCR7	Gain Side C Receiver 7	19.83	NO
GCR8	Gain Side C Receiver 8	19.83	NO
GDR1	Gain Side D Receiver 1	19.83	NO
GDR2	Gain Side D Receiver 2	19.83	NO
GDR3	Gain Side D Receiver 3	19.83	NO
GDR4	Gain Side D Receiver 4	19.83	NO
GDR5	Gain Side D Receiver 5	19.83	NO
GDR6	Gain Side D Receiver 6	19.83	NO
GDR7	Gain Side D Receiver 7	19.83	NO
GDR8	Gain Side D Receiver 8	19.83	NO

ACRt Sonde

TPUL	Tension Pull	2.97	NO	
F1R1	ACRT 12KHz - 80in R value	9.22	BLK	0.000
F1X1	ACRT 12KHz - 80in X value	9.22	BLK	0.000
F1R2	ACRT 12KHz - 50in R value	6.72	BLK	0.000
F1X2	ACRT 12KHz - 50in X value	6.72	BLK	0.000
F1R3	ACRT 12KHz - 29in R value	5.22	BLK	0.000
F1X3	ACRT 12KHz - 29in X value	5.22	BLK	0.000
F1R4	ACRT 12KHz - 17in R value	4.22	BLK	0.000
F1X4	ACRT 12KHz - 17in X value	4.22	BLK	0.000
F1R5	ACRT 12KHz - 10in R value	3.72	BLK	0.000
F1X5	ACRT 12KHz - 10in X value	3.72	BLK	0.000
F1R6	ACRT 12KHz - 6in R value	3.47	BLK	0.000
F1X6	ACRT 12KHz - 6in X value	3.47	BLK	0.000
F2R1	ACRT 36KHz - 80in R value	9.22	BLK	0.000
F2X1	ACRT 36KHz - 80in X value	9.22	BLK	0.000
F2R2	ACRT 36KHz - 50in R value	6.72	BLK	0.000
F2X2	ACRT 36KHz - 50in X value	6.72	BLK	0.000
F2R3	ACRT 36KHz - 29in R value	5.22	BLK	0.000
F2X3	ACRT 36KHz - 29in X value	5.22	BLK	0.000
F2R4	ACRT 36KHz - 17in R value	4.22	BLK	0.000
F2X4	ACRT 36KHz - 17in X value	4.22	BLK	0.000
F2R5	ACRT 36KHz - 10in R value	3.72	BLK	0.000
F2X5	ACRT 36KHz - 10in X value	3.72	BLK	0.000
F2R6	ACRT 36KHz - 6in R value	3.47	BLK	0.000
F2X6	ACRT 36KHz - 6in X value	3.47	BLK	0.000
F3R1	ACRT 72KHz - 80in R value	9.22	BLK	0.000
F3X1	ACRT 72KHz - 80in X value	9.22	BLK	0.000
F3R2	ACRT 72KHz - 50in R value	6.72	BLK	0.000
F3X2	ACRT 72KHz - 50in X value	6.72	BLK	0.000
F3R3	ACRT 72KHz - 29in R value	5.22	BLK	0.000
F3X3	ACRT 72KHz - 29in X value	5.22	BLK	0.000
F3R4	ACRT 72KHz - 17in R value	4.22	BLK	0.000
F3X4	ACRT 72KHz - 17in X value	4.22	BLK	0.000
F3R5	ACRT 72KHz - 10in R value	3.72	BLK	0.000
F3X5	ACRT 72KHz - 10in X value	3.72	BLK	0.000
F3R6	ACRT 72KHz - 6in R value	3.47	BLK	0.000
F3X6	ACRT 72KHz - 6in X value	3.47	BLK	0.000
RMUD	Mud Resistivity	12.76	BLK	0.000
F1RT	Transmitter Current Raw 12K X Receiver	2.97	BLK	0.000
F1XT	Transmitter Reference 12 KHz Imaginary Signal	2.97	BLK	0.000
F2RT	Transmitter Reference 36 KHz Real Signal	2.97	BLK	0.000
F2XT	Transmitter Reference 36 KHz Imaginary Signal	2.97	BLK	0.000

F3RT	Transmitter Reference 72 KHz Real Signal	2.97	BLK	0.000
F3XT	Transmitter Reference 72 KHz Imaginary Signal	2.97	BLK	0.000
TFPU	Upper Feedpipe Temperature Calculated	2.97	BLK	0.000
TFPL	Lower Feedpipe Temperature Calculated	2.97	BLK	0.000
ITMP	Instrument Temperature	2.97	BLK	0.000
TCVA	Temperature Correction Values Loop Off	2.97	NO	
TIDV	Instrument Temperature Derivative	2.97	NO	
TUDV	Upper Temperature Derivative	2.97	NO	
TLDV	Lower Temperature Derivative	2.97	NO	
TRBD	Receiver Board Temperature	2.97	NO	

SDLT Pad

TPUL	Tension Pull	82.79	NO	
NAB	Near Above	82.61	BLK	0.920
NHI	Near Cesium High	82.61	BLK	0.920
NLO	Near Cesium Low	82.61	BLK	0.920
NVA	Near Valley	82.61	BLK	0.920
NBA	Near Barite	82.61	BLK	0.920
NDE	Near Density	82.61	BLK	0.920
NPK	Near Peak	82.61	BLK	0.920
NLI	Near Lithology	82.61	BLK	0.920
NBAU	Near Barite Unfiltered	82.61	BLK	0.250
NLIU	Near Lithology Unfiltered	82.61	BLK	0.250
FAB	Far Above	82.96	BLK	0.250
FHI	Far Cesium High	82.96	BLK	0.250
FLO	Far Cesium Low	82.96	BLK	0.250
FVA	Far Valley	82.96	BLK	0.250
FBA	Far Barite	82.96	BLK	0.250
FDE	Far Density	82.96	BLK	0.250
FPK	Far Peak	82.96	BLK	0.250
FLI	Far Lithology	82.96	BLK	0.250
PTMP	Pad Temperature	82.80	BLK	0.920
NHV	Near Detector High Voltage	82.19	NO	
FHV	Far Detector High Voltage	82.19	NO	
ITMP	Instrument Temperature	82.19	NO	
DDHV	Detector High Voltage	82.19	NO	

Microlog Pad

TPUL	Tension Pull	82.98	NO	
MINV	Microlog Lateral	82.98	BLK	0.750
MNOR	Microlog Normal	82.98	BLK	0.750

Data: FLINN_A_3306\0001 SP-GTET-CSNG-DSN-SDL-FLEX-IDT-ICT-WAVE-ACRT-CH\IDLE

Date: 17-Jul-13 20:37:04

HALLIBURTON

Plot Time: 18-Jul-13 00:58:26

Plot Range: 620 ft to 4806.83 ft

Data: FLINN_A_3306\Well Based\CASING\

Plot File: \\LOCAL-IFLINN_A_3306\0001 SP-GTET-CSNG-DSN-SDL-FLEX-IDT-ICT-WAVE-ACRT-CHIPORVAHV_2_IQ_LIB

ANNULAR HOLE VOLUME PLOT

0	Gamma API	150				
	api					
6	Bit Size	16				
	Bit Size					
			MUDCAKE		MUDCAKE	
			20	0 0	20	

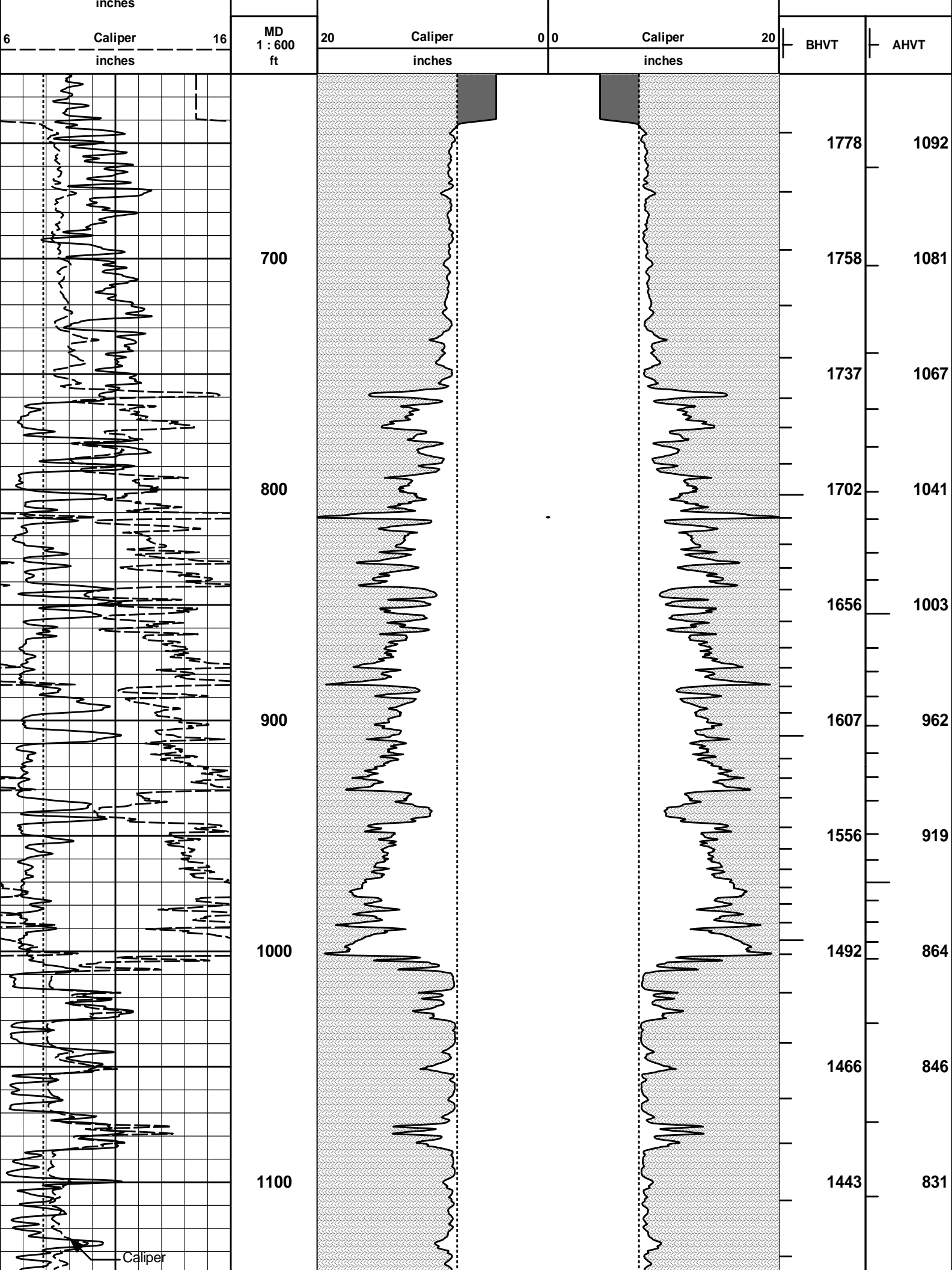

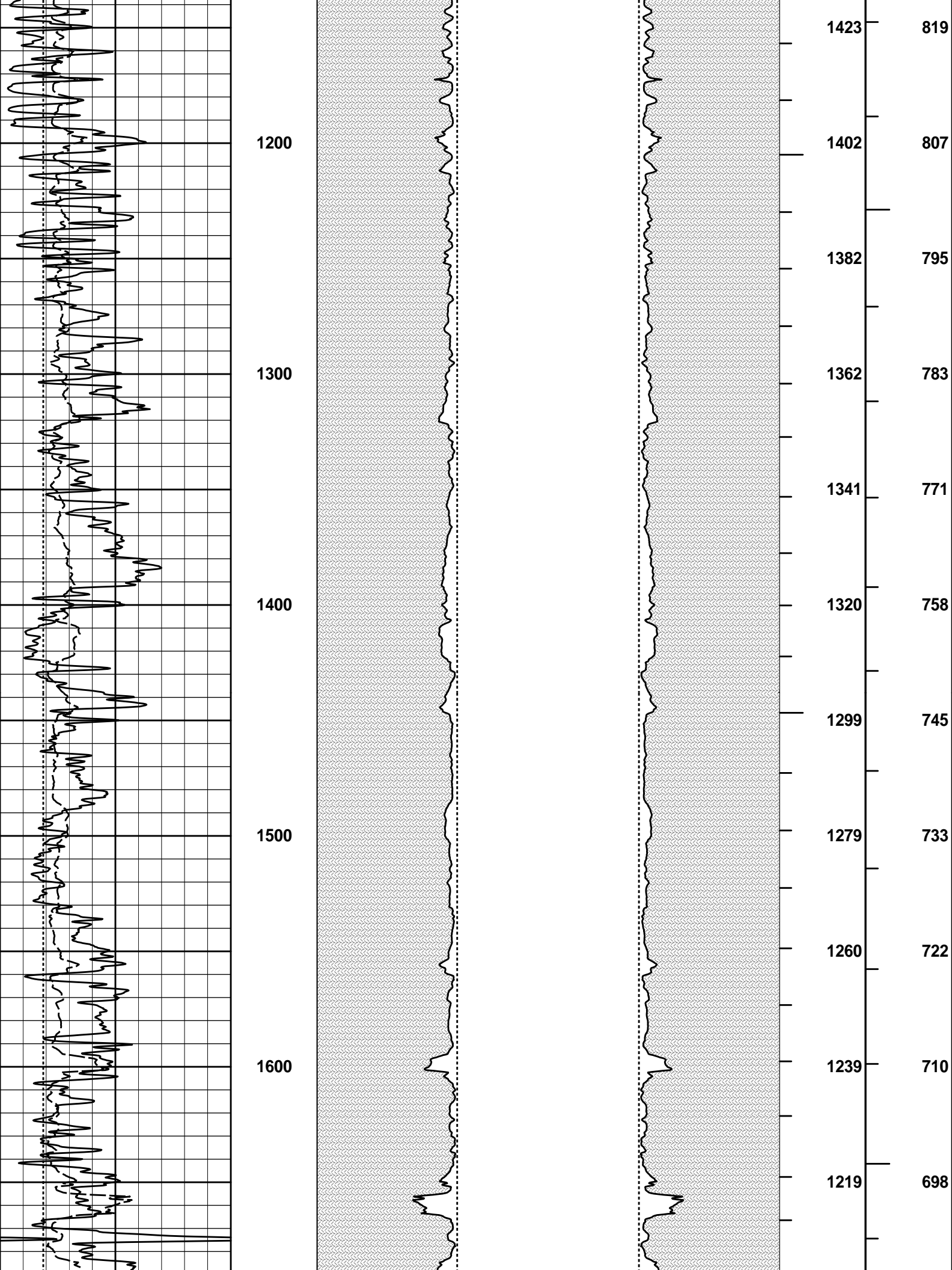

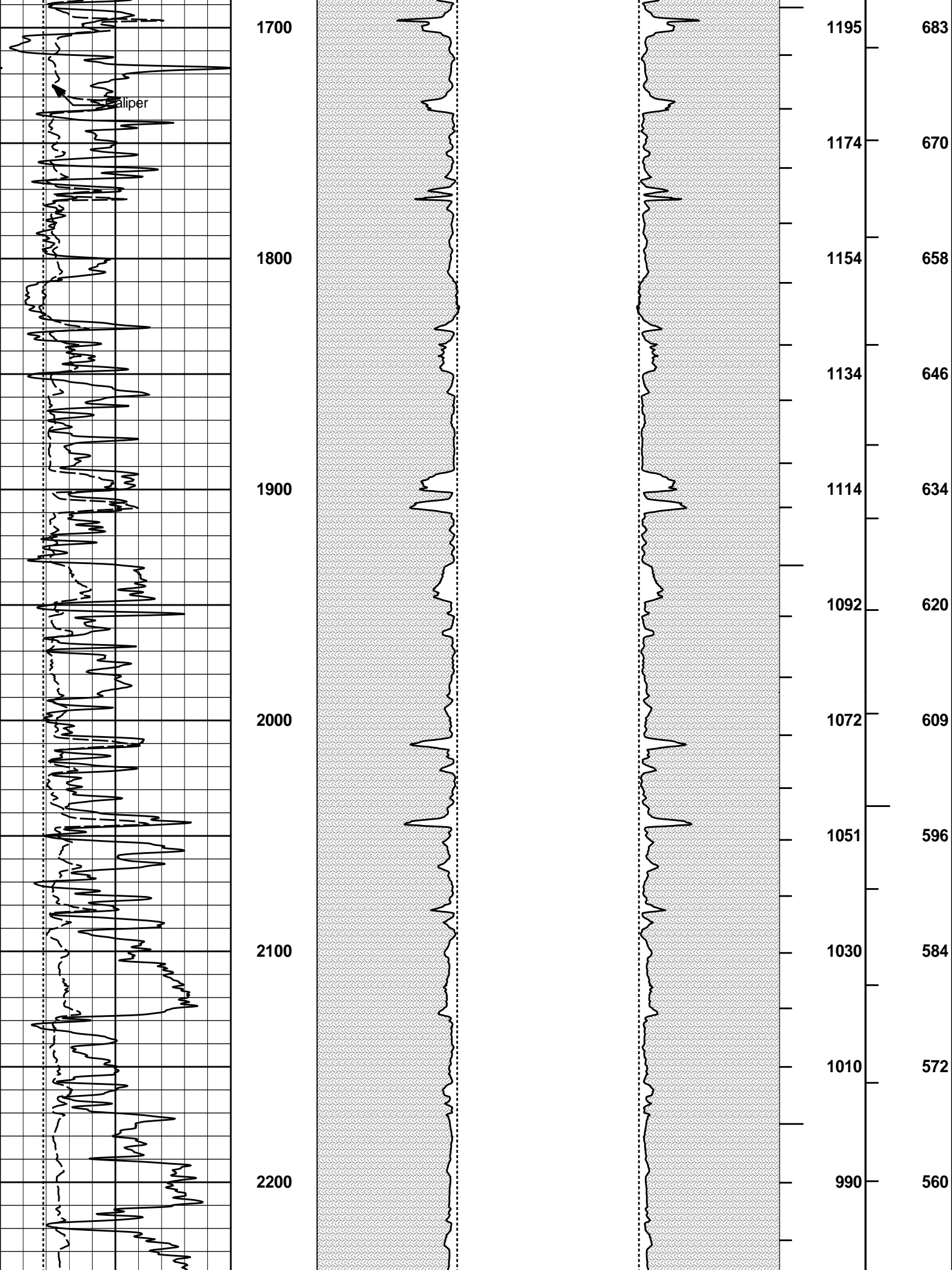

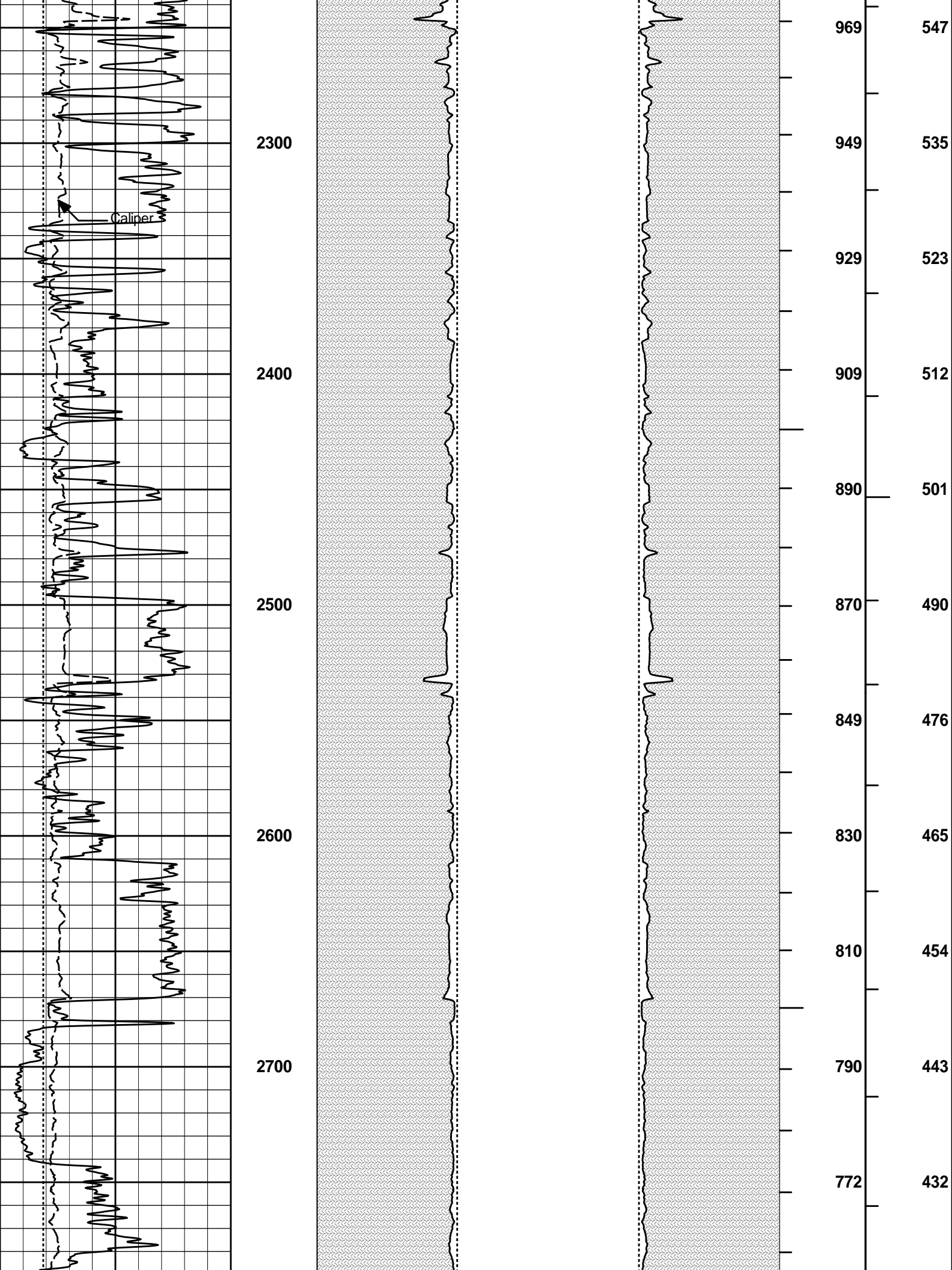

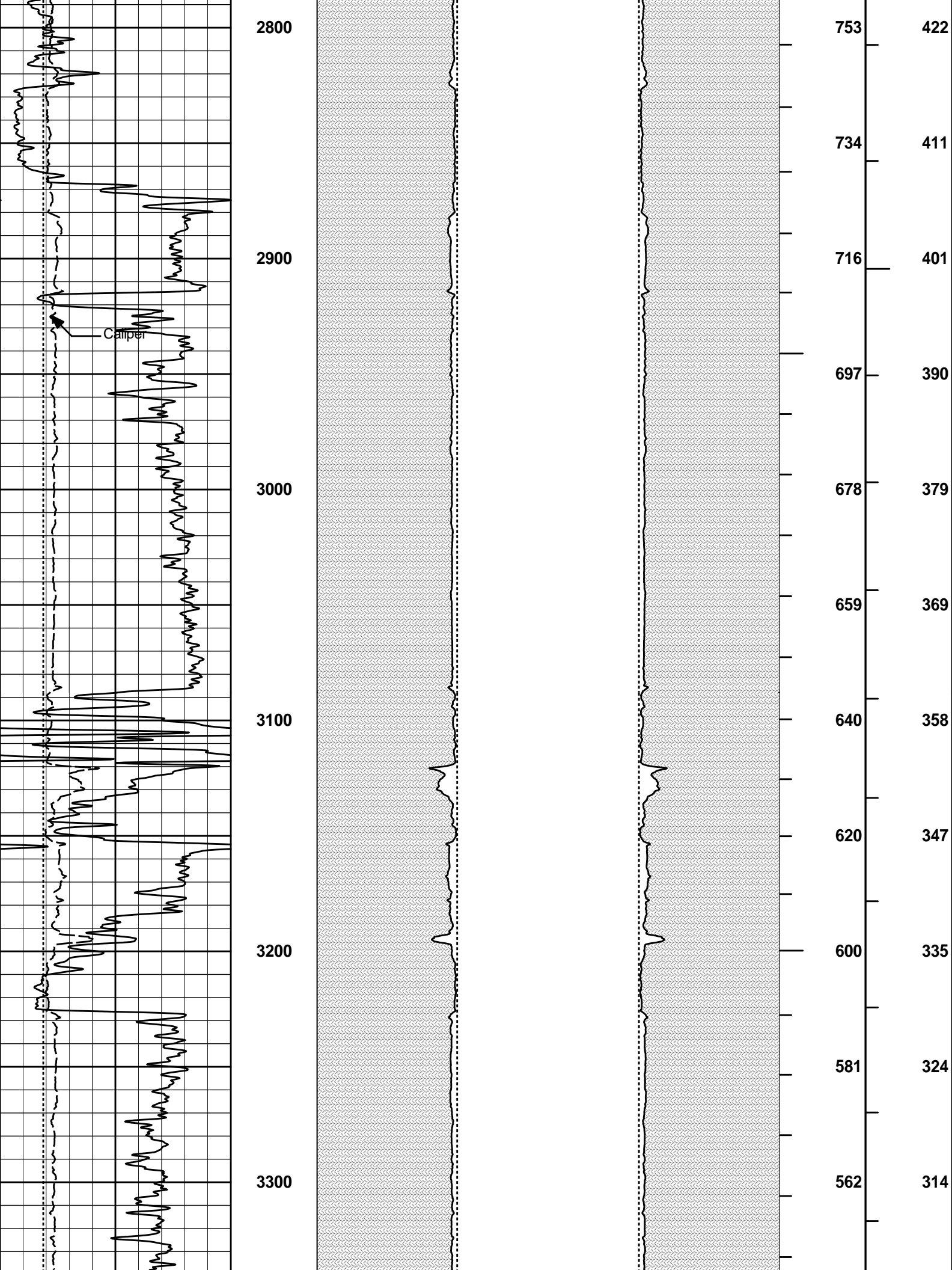

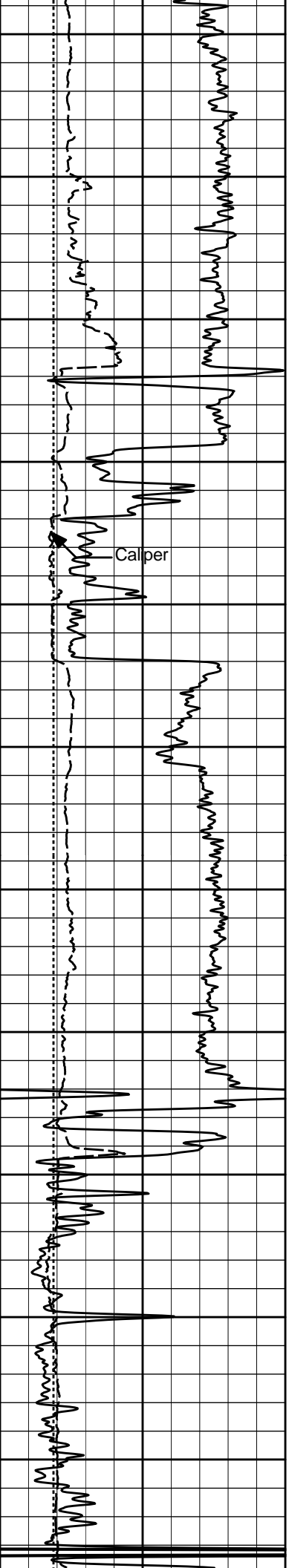

3400
3500
3600
3700
3800

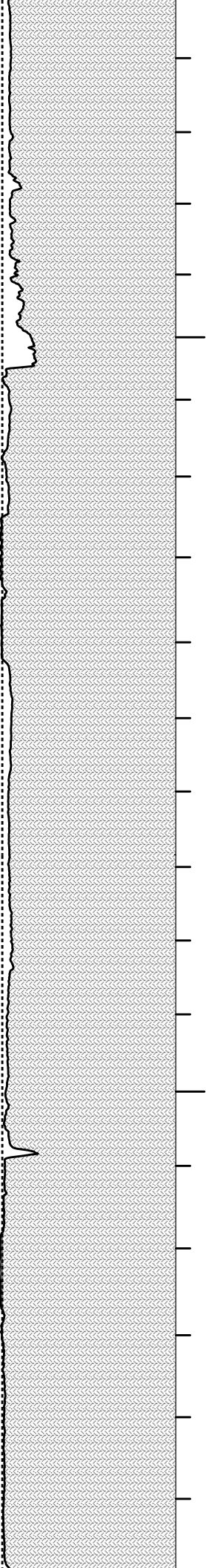
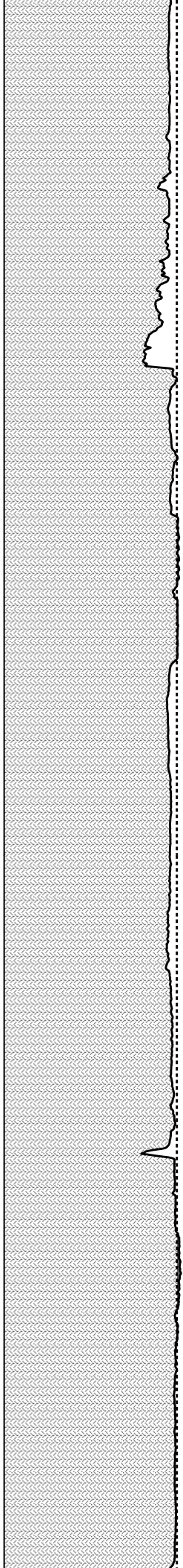

543 303
524 292
503 279
482 266
464 257
446 247
427 236
408 225
389 214
372 206
355 197

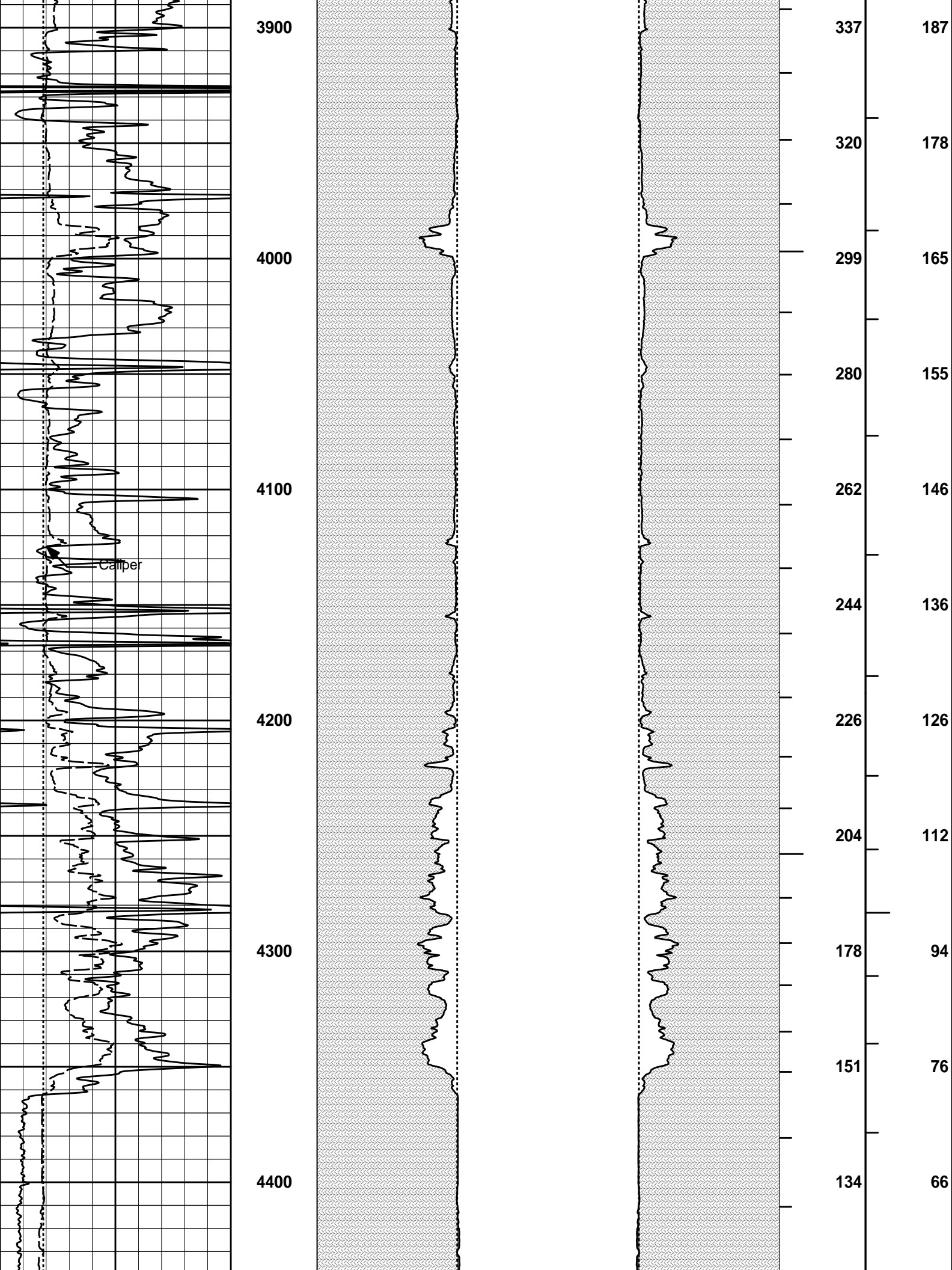

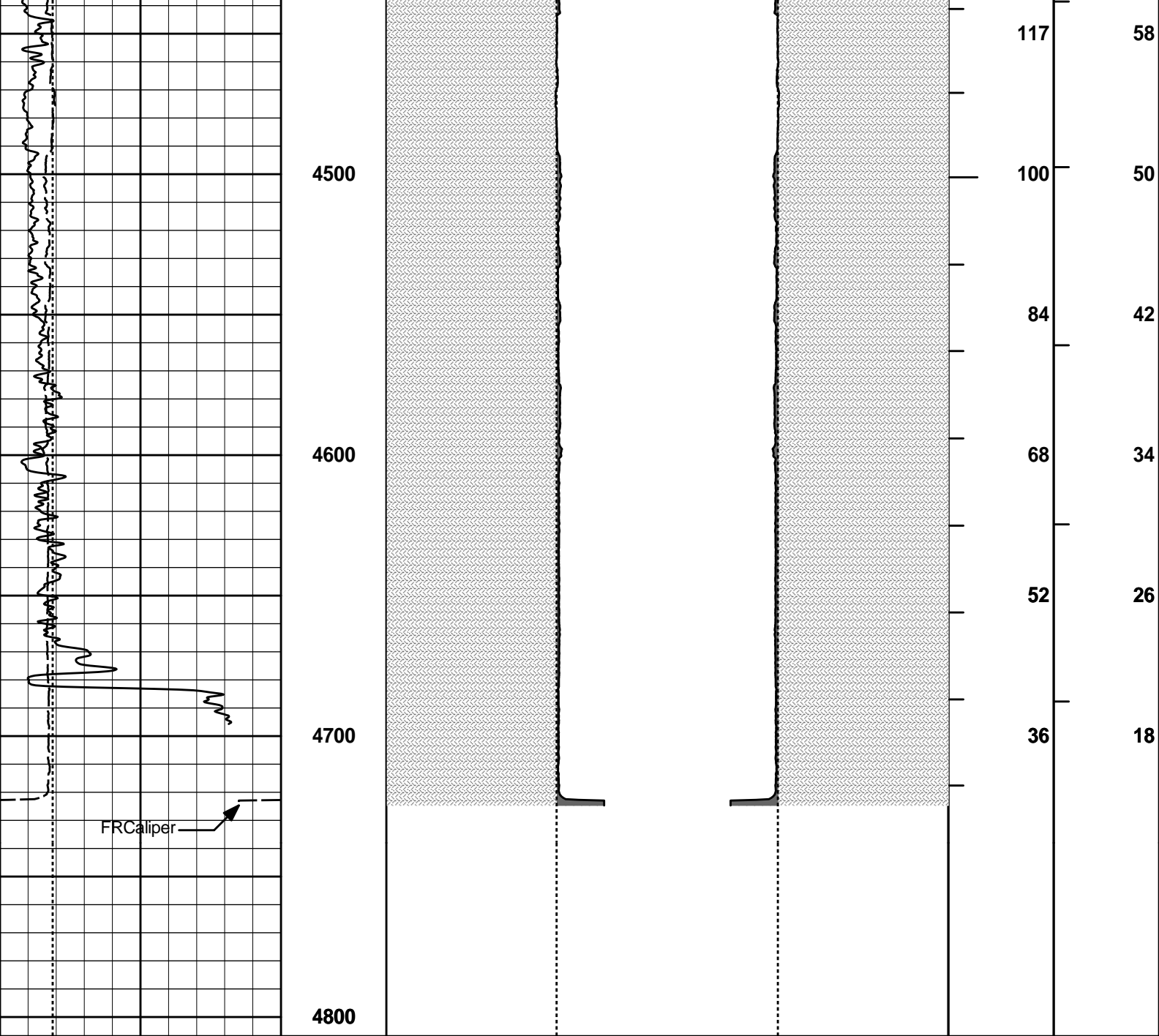

6	Caliper	16	MD 1 : 600 ft	20	Caliper	0 0	20	BHVT	AHVT
	inches					inches			
6	Bit Size	16		20	Bit Size	0 0	20		
	inches								
0	Gamma API	150							
	api								
					MUDCAKE		MUDCAKE		

HALLIBURTON

Plot Time: 18-Jul-13 00:58:34
 Plot Range: 620 ft to 4806.83 ft
 Data: FLINN_A_3306\Well Based\CASING\
 Plot File: \\LOCAL-FLINN_A_3306\0001 SP-GTET-CSNG-DSN-SDL-FLEX-IDT-ICT-WAVE-ACRT-CHIPORVAHV_2_IQ_LIB

ANNULAR HOLE VOLUME PLOT

COMPANY	SANDRIDGE ENERGY
WELL	FLINN_A_3306_1_11

WELL FLINN A 3306 T-11

FIELD STOHRVILLE

COUNTY HARPER STATE KANSAS

HALLIBURTON

SPECTRAL DENSITY
DUAL SPACED NEUTRON
LOG