

**U.S. Department of Energy  
FEDERAL ASSISTANCE REPORTING CHECKLIST  
AND INSTRUCTIONS FOR RD&D PROJECTS**

1. Identification Number: <b>DE-FE0006821</b>	2. Program/Project Title: <b>Small Scale Field Test Demonstration CO2 Sequestration</b>
--	--

3. Recipient:  
**University of Kansas Center for Research, Inc.**

4. Reporting Requirements:	Frequency	Addressees															
<b>A. MANAGEMENT REPORTING</b> <input checked="" type="checkbox"/> Research Performance Progress Report (RPPR) <input checked="" type="checkbox"/> Special Status Report	Q A	<a href="mailto:FITS@NETL.DOE.GOV">FITS@NETL.DOE.GOV</a>  <a href="mailto:FITS@NETL.DOE.GOV">FITS@NETL.DOE.GOV</a>															
<b>B. SCIENTIFIC/TECHNICAL REPORTING</b> (Reports/Products must be submitted with appropriate DOE F 241. The 241 forms are available at <a href="http://www.osti.gov/elink">www.osti.gov/elink</a> )  <table style="width:100%; border: none;"> <tr> <td style="text-align: center;">Report/Product</td> <td style="text-align: center;">Form</td> <td></td> </tr> <tr> <td><input checked="" type="checkbox"/> Final Scientific/Technical Report</td> <td>DOE F 241.3</td> <td style="text-align: center;">FG</td> </tr> <tr> <td><input checked="" type="checkbox"/> Conference papers/proceedings*</td> <td>DOE F 241.3</td> <td style="text-align: center;">A</td> </tr> <tr> <td><input type="checkbox"/> Software/Manual</td> <td>DOE F 241.4</td> <td></td> </tr> <tr> <td><input type="checkbox"/> Other (see special instructions)</td> <td>DOE F 241.3</td> <td></td> </tr> </table> * <i>Scientific and technical conferences only</i>	Report/Product	Form		<input checked="" type="checkbox"/> Final Scientific/Technical Report	DOE F 241.3	FG	<input checked="" type="checkbox"/> Conference papers/proceedings*	DOE F 241.3	A	<input type="checkbox"/> Software/Manual	DOE F 241.4		<input type="checkbox"/> Other (see special instructions)	DOE F 241.3		FG A	<a href="http://www.osti.gov/elink-2413">http://www.osti.gov/elink-2413</a> <a href="http://www.osti.gov/elink-2413">http://www.osti.gov/elink-2413</a>
Report/Product	Form																
<input checked="" type="checkbox"/> Final Scientific/Technical Report	DOE F 241.3	FG															
<input checked="" type="checkbox"/> Conference papers/proceedings*	DOE F 241.3	A															
<input type="checkbox"/> Software/Manual	DOE F 241.4																
<input type="checkbox"/> Other (see special instructions)	DOE F 241.3																
<b>C. FINANCIAL REPORTING</b> <input checked="" type="checkbox"/> SF-425 Federal Financial Report	Q, FG	<a href="mailto:FITS@NETL.DOE.GOV">FITS@NETL.DOE.GOV</a>															
<b>D. CLOSEOUT REPORTING</b> <input checked="" type="checkbox"/> Patent Certification <input checked="" type="checkbox"/> SF-428 & 428B Final Property Report <input type="checkbox"/> Other	FC FC	<a href="mailto:FITS@NETL.DOE.GOV">FITS@NETL.DOE.GOV</a> <a href="mailto:FITS@NETL.DOE.GOV">FITS@NETL.DOE.GOV</a>															
<b>E. OTHER REPORTING</b> <input checked="" type="checkbox"/> Annual Indirect Cost Proposal <input type="checkbox"/> Audit of For-Profit Recipients <input checked="" type="checkbox"/> SF-428 Tangible Personal Property Report Forms Family <input checked="" type="checkbox"/> Other – see block 5 below	O  A A	See block 5 below for instructions.  <a href="mailto:FITS@NETL.DOE.GOV">FITS@NETL.DOE.GOV</a> <a href="mailto:FITS@NETL.DOE.GOV">FITS@NETL.DOE.GOV</a>															

FREQUENCY CODES AND DUE DATES:

- A - Within 5 calendar days after events or as specified.
- FG- Final; 90 calendar days after the project period ends.
- FC- Final; End of Effort.
- Y - Yearly; 90 calendar days after the end of the reporting period.
- S - Semiannually; within 30 calendar days after end of project year and project half-year.
- Q - Quarterly; within 30 days after end of the reporting period.
- Y180 – Yearly; 180 days after the end of the recipient's fiscal year
- O - Other; See instructions for further details.

5. Special Instructions:

**Annual Indirect Cost Proposal** – If DOE is the Cognizant Federal Agency, then the proposal should be sent to [FITS@NETL.DOE.GOV](mailto:FITS@NETL.DOE.GOV) . Otherwise, it should be sent to the Cognizant Federal Agency.

Other – The Recipient shall provide all deliverables as contained in Section D of Attachment 2 Statement of Project Objectives.

**QUARTERLY PROGRESS REPORT**

To

**DOE-NETL**

**Brian Dressel, Program Manager**

**Award Number: DE-FE0006821**

**SMALL SCALE FIELD TEST DEMONSTRATING CO<sub>2</sub> SEQUESTRATION IN  
ARBUCKLE SALINE AQUIFER AND BY CO<sub>2</sub>-EOR AT WELLINGTON FIELD,  
SUMNER COUNTY, KANSAS**

**Project Director/Principal Investigator:**

**W. Lynn Watney**

**Senior Scientific Fellow**

**Kansas Geological Survey**

**Ph: 785-864-2184, Fax: 785-864-5317**

**[lwatney@kgs.ku.edu](mailto:lwatney@kgs.ku.edu)**

**Joint Principal Investigator:**

**Jason Rush**

**Prepared by Lynn Watney**

**Date of Report: February 6, 2014**

**DUNS Number: 076248616**

**Recipient: University of Kansas Center for Research &**

**Kansas Geological Survey**

**1930 Constant Avenue**

**Lawrence, KS 66047**

**Project/Grant Period: 10/1/2011 through 9/30/2015**

**Eighth Quarterly Report**

**Period Covered by the Report: October 1, 2013 through December 31, 2013**

**Signature of Submitting Official:**



## EXECUTIVE SUMMARY

### Project Objectives

The objectives of this project are to understand the processes that occur when a maximum of 70,000 metric tonnes of CO<sub>2</sub> are injected into two different formations to evaluate the response in different lithofacies and depositional environments. The evaluation will be accomplished through the use of both *in situ* and indirect MVA (monitoring, verification, and accounting) technologies. The project will optimize for carbon storage accounting for 99% of the CO<sub>2</sub> using lab and field testing and comprehensive characterization and modeling techniques.

CO<sub>2</sub> will be injected under supercritical conditions to demonstrate state-of-the-art MVA tools and techniques to monitor and visualize the injected CO<sub>2</sub> plume and to refine geomodels developed using nearly continuous core, exhaustive wireline logs, and well tests and a multi-component 3D seismic survey. Reservoir simulation studies will map the injected CO<sub>2</sub> plume and estimate tonnage of CO<sub>2</sub> stored in solution, as residual gas, and by mineralization and integrate MVA results and reservoir models shall be used to evaluate CO<sub>2</sub> leakage. A rapid-response mitigation plan will be developed to minimize CO<sub>2</sub> leakage and provide comprehensive risk management strategy. A documentation of best practice methodologies for MVA and application for closure of the carbon storage test will complete the project. The CO<sub>2</sub> shall be supplied from a reliable facility and have an adequate delivery and quality of CO<sub>2</sub>. The project shall install compression, chilling, and transport facilities at the ethanol plant for truck transport to the injection site.

### Scope of Work

Budget Period 1 includes updating reservoirs models at Wellington Field and filing Class II and Class VI injection permit applications. Static 3D geocellular models of the Mississippian and Arbuckle shall integrate petrophysical information from core, wireline logs, and well tests with spatial and attribute information from their respective 3D seismic volumes. Dynamic models (composition simulations) of these reservoirs shall incorporate this information with laboratory data obtained from rock and fluid analyses to predict the properties of the CO<sub>2</sub> plume through time. The results will be used as the basis to establish the MVA and as a basis to compare with actual CO<sub>2</sub> injection. The small scale field test shall evaluate the accuracy of the models as a means to refine them in order to improve the predictions of the behavior and fate of CO<sub>2</sub> and optimizing carbon storage.

Budget Period 2 includes drilling and equipping a new borehole into the Mississippian reservoir for use in the first phase of CO<sub>2</sub> injection; establishing MVA infrastructure and acquiring baseline data; establishing source of CO<sub>2</sub> and transportation to the injection site; building injection facilities in the oil field; and injecting CO<sub>2</sub> into the Mississippian-age spiculitic cherty dolomitic open marine carbonate reservoir as part of the small scale carbon storage project.

In Budget Period 3, contingent on securing a Class VI injection permit, the drilling and completion of an observation well will be done to monitor injection of CO<sub>2</sub> under supercritical conditions into the Lower Ordovician Arbuckle shallow (peritidal) marine dolomitic reservoir. Monitoring during pre-injection, during injection, and post injection will be accomplished with

MVA tools and techniques to visualize CO<sub>2</sub> plume movement and will be used to reconcile simulation results. Necessary documentation will be submitted for closure of the small scale carbon storage project.

## **Project Goals**

The proposed small scale injection will advance the science and practice of carbon sequestration in the Midcontinent by refining characterization and modeling, evaluating best practices for MVA tailored to the geologic setting, optimize methods for remediation and risk management, and provide technical information and training to enable additional projects and facilitate discussions on issues of liability and risk management for operators, regulators, and policy makers.

The data gathered as part of this research effort and pilot study will be shared with the Southwest Sequestration Partnership (SWP) and integrated into the National Carbon Sequestration Database and Geographic Information System (NATCARB) and the 6th Edition of the Carbon Sequestration Atlas of the United States and Canada.

## **Project Deliverables by Task**

- 1.5 Well Drilling and Installation Plan (Can be Appendix to PMP or Quarterly Report)
- 1.6 MVA Plan (Can be Appendix to PMP or Quarterly Report)
- 1.7 Public Outreach Plan (Can be Appendix to PMP)
- 1.8 Arbuckle Injection Permit Application Review go/no go Memo
- 1.9 Mississippian Injection Permit Application Review go/no go Memo
- 1.10 Site Development, Operations, and Closure Plan (Can be Appendix to PMP)
- 2.0 Suitable geology for Injection Arbuckle go/no go Memo
- 3.0 Suitable geology for Injection Mississippian go/no go Memo
- 11.2 Capture and Compression Design and Cost Evaluation go/no go Memo
- 19 Updated Site Characterization/Conceptual Models (Can be Appendix to Quarterly Report)
- 21 Commercialization Plan (Can be Appendix to Quarterly Report).
- 30 Best Practices Plan (Can be Appendix to Quarterly or Final Report)

## **ACCOMPLISHMENTS**

1. Completed Well Drilling and Installation Plan Subtask 1.5. (See Appendix A-1 Drilling and Well Installation Plan)
2. Completed Subtask 1.6. MVA Plan (See Appendix A-2 Testing and Monitoring Plan)
3. Completed Subtask 1.7. Public Outreach Plan (See Appendix A-3 Wellington Public Outreach)
4. Completed Subtask 1.8. Arbuckle Injection Permit Application Review go/no go Memo (See Appendix A-4 Permit Application)
5. Completed Subtask 1.10. Site Development, Operations, and Closure Plan (Please see Appendix A-5 Operations and Closure Plan and Appendix A-6 Post-Injection Site Care and Site Closure Plan)

## Milestone Status Report

Task	Budget Period	Number	Milestone Description
Task 2.		1	1 Site Characterization of Arbuckle Saline Aquifer System - Wellington Field
Task 3.		1	2 Site characterization of Mississippian Reservoir for CO2 EOR - Wellington Field
Task 10.		2	3 Pre-injection MVA - establish background (baseline) readings
Task 13.		2	4 Retrofit Arbuckle Injection Well (#1-28) for MVA Tool Installation
Task 18.	3-yr1		5 Compare Simulation Results with MVA Data and Analysis and Submit Update of Site Characterization, Modeling, and Monitoring Plan
Task 22.	3-yr1		6 Recondition Mississippian Boreholes Around Mississippian CO2-EOR injector
Task 27.	3-yr2		7 Evaluate CO2 Sequestration Potential of CO2-EOR Pilot
Task 28.	3-yr2		8 Evaluate Potential of Incremental Oil Recovery and CO2 Sequestration by CO2-EOR - Wellington field

Task 2, Site characterization of the Arbuckle saline aquifer system in Wellington Field, has been completed and incorporated into the Class VI injection application.

Task 3, Site characterization of the Mississippian reservoir for CO2-EOR in Wellington Field will be completed in the first quarter of 2014 for use in selecting drilling site for use in the Class II application to also be submitted in the first quarter of 2014.

### Project Schedule

**CO2 Supply** -- Discussion with three industrial suppliers reestablished as complications developed with primary supplier. Costs have been revisited based on daily supply and combining sources.

Some of the deliberations with suppliers are provided as excerpts below:

10/11/13 -- Very productive meeting with Company A and their CO2-EOR Director in Wichita, hosted by Berexco. A field trip was taken to Wellington. Company A and will provide quote to supply 50,000 tonnes from fertilizer plant in Oklahoma. Continued discussions with Company B to supply CO2 from ethanol plant. At time of negotiations, the source hinged on this company becoming a contractor under KUCR.

10/21/2013 -- Teleconference with Company C expecting to receive official quote during week of October 28th from a fertilizer plant in Kansas.

10/22/2013 -- Received quote for CO2 from Company D from another fertilizer plant in Oklahoma.

10/29/201 -- KUCR working with Company B on a subcontract details.

11/20/2013 -- Company B reviewing KUCR subcontract and will present to management in December.

12/10/2013 -- Second option to presented to Company B to purchase CO2. Relayed delays to Robert Trautz, PI of FOA 798 - Fiber Optic Cable acoustic monitoring. Update options spreadsheet with new market cost of CO2 based on CO2 prices.

Advantages of an industrial supplier include and thus are being seriously considered:

1. CO2 injection in the Mississippian oil reservoir could begin in late summer;
2. Schedule would accommodate the fiber optic project FOA 798;
- 3 The outlay of funds from DOE could initially be limited to the CO2 Mississippian until Class VI application is approved.
5. Industrial sources are well established trusted companies with experience in utilizing CO2 in the oil field, minimizing potential for the delay in startup and disruptions along the way.
6. The industrial sources would help to keep project within five years.

**Class VI Injection application – October 10, 2013** --- Class VI application submitted to DOE and Berexco on for review prior to submitting to EPA. **10/29/2013** -- Berexco received a binder with Class VI application in print form. DOE returned reviews through Section 4. Dennis Hedke provided a final prestack depth migration volume for Wellington that will improve the Arbuckle geomodel. New seismic volume is merged with Noble's seismic distributing to Dana, Jason, and George T. at KU. **11/20/13** -- DOE review of the Class VI application is complete and revisions are being completed. Berexco continues to review. **12/10/13** -- DOE completed review and penultimate revision being prepared pending receipt of review from Berexco.

**Class II CO2-EOR injection application** -- 10/11/13 - CMG simulation underway and initial results to be presented next week. 10/29/13 -- Initial simulations by Eugene and more to come to use in confirming location of Mississippian injection well. 12/10/13 -- Final simulations expected later in December so that decisions can be made about precise well location. Anticipate receipt of Class II permit to inject in Mississippian will require 1 month.

**Revision of SOPO** -- 10/29/13 – SOPO has been revised to be submitted pending selection of CO2 source. Gantt Chart/schedule will change depending on source(s) that is selected. SOPO now deploys Mississippian infrastructure first. 12/10/2013 -- Revising KU side of budget including removal of LiDAR from budget and replacing with IRIS-PASSCAL seismometer installation. State of Kansas will provide cost to install 15 seismometers into bedrock at locations suited to monitor both the Mississippian and Arbuckle injections. Rick Miller will join Watney as lead to install equipment, obtain, process, and interpret the data. Plans are to deploy seismometers in Spring 2014 to acquire background data.

#### **Activities of Lawrence Berkeley National Lab**

No work has been completed or funds expended during this quarter by LBNL.

## **ONGOING ACTIVITIES –**

- 1) Complete negotiations by Dana Wreath (Berexo) and KGS with CO2 suppliers to receive final bids for the CO2, ensuring reliable safe delivery, maximize volume of CO2, option to be involved in the onsite injection.
- 2) Complete DOE budget review of CO2 costs and revise Berexco subcontract completed via a 9.2 form; formalize schedule and update SOPO and Gantt Chart and begin BP2
- 3) Complete and submit Class VI injection application to EPA
- 4) Complete modeling and set the well location in order to submit Class II permit to State for Mississippian test injection.
- 4) Obtain permission from DOE to commence field activities – drill Mississippian injection well (revised BP2)
- 5) Preparations to begin BP2 to commence field work and deploy MVA activities suited for the Mississippian including InSAR, seismometers/passive seismic, adapt producing wells to permit sampling fluids.

## **TASK 1. PROJECT MANAGEMENT AND REPORTING**

**Subtask 1.5 Well Drilling and Installation Plan (See Appendix A-1)**

**Subtask 1.6. MVA Plan (See Appendix A-2 Testing and Monitoring Plan)**

**Subtask 1.7. Public Outreach Plan (See Appendix A-3 Wellington Public Outreach)**

**Subtask 1.8. Arbuckle Injection Permit Application Review go/no go Memo (See Appendix A-4 Permit Application)**

**Subtask 1.10. Site Development, Operations, and Closure Plan (Please see Appendix A-5 Operations and Closure Plan and Appendix A-6 Post-Injection Site Care and Site Closure Plan)**

### **Key Findings**

1. At the time of the writing, all of the questions and comments for internal reviews for the Class VI injection application have been addressed and final copy will be provided to Berexco for signature and then will be submitted to Region 7 EPA on March 1. EPA has been informed of this submission date.
2. CO2 supplier will be settled in first quarter 2014.

## **Plans for First Quarter 2014**

1. Choose CO2 source with DOE and Berexco based on summary for vendor, delivery schedule, total amount, daily delivery, and costs.
2. Submit Class VI and Class injection applications.
3. Complete SOPO and budgeting and reevaluating what MVA is deployed for Mississippian test.
4. Submit no cost extension.

## **PRODUCTS**

### **Publications, conference papers, and presentations**

Yevhen Holubnyak, Jennifer Raney, Lynn Watney, Jason Rush, Mina Fazelalavi, and John Doveton, 2013, Dynamic Simulation of Pilot Scale CO2 Injection in the Arbuckle Saline Aquifer at Wellington Field in Southern Kansas: American Geophysical Union, Fall Meeting, San Francisco.

Jennifer Raney, 2013, Using improved Technology for Widespread Application of a Geological Carbon Storage Study: American Geophysical Union, Fall Meeting, San Francisco.

## **PARTICIPANTS & OTHER COLLABORATING ORGANIZATIONS**

A project organization chart follows. The work authorized in this budget period includes office tasks related to preparation of reports and application for a Class VI permit to inject CO2 into the Arbuckle saline aquifer. Tasks associated with reservoir characterization and modeling are funded in contract DE-FE0002056.

## ORGANIZATION CHART

Kansas Geological Survey		
<u>Name</u>	<u>Project Job Title</u>	<u>Primary Responsibility</u>
Lynn Watnev	Project Leader, Joint Principal Investigator	Geology, information synthesis, point of contact
Yevhen Holubnyak	Petroleum Engineer	Reservoir engineer, dynamic modeling, synthesis
Jason Rush	Joint Principal Investigator	Geology, static modeling, data integration, synthesis
John Doveton	Co-Principal Investigator	Log petrophysics, geostatistics
Dave Newell	Co-Principal Investigator	Fluid geochemistry
Rick Miller	Geophysicist	2D seismic acquire & interpretation
TBN	Geology Technician	LiDAR/InSAR support, water well drilling/completion
Tiraz Birdie	President, TBirdie Consulting, Inc.	Assemble and analyze data, report writing
		Hydrogeologic modeling, permitting, MVA, integration
KU Department of Geology		
Michael Taylor	Co-Principal Investigator	Structural Geology, analysis of InSAR, LiDAR, seismometer array
TBN	Graduate Research Assistant	Structural Geology, analysis of InSAR and LiDAR, seismometer array
Kansas State University		
Saugata Datta	Principal Investigator	
TBN	Graduate Research Assistant	Aqueous geochemistry
TBN	3- Undergraduate Research Assistants	
Lawrence Berkeley National Laboratory		
Tom Daley	Co-Principal Investigator	Geophysicist, analysis of crosshole and CASSM data
		Hydrogeology, analysis of soil gas measurements
Barry Freifeld	Co-Principal Investigator	Mechanical Engineer, analysis of U-Tube sampler
Sandia Technologies, Houston		
Dan Collins	Geologist	Manage CASSM and U-Tube operation
David Freeman	Field Engineer	Manage field install of CASSM and U-Tube
Berecoco, LLC		
Dana Wreath	VP Berecoco, LLC	Engineering, Manager of Wellington Field
Randy Koudele	Reservoir engineer	Engineering
Staff of Wellington Field		Field operations
Beredco Drilling team		Mississippian and Arbuckle drilling operations
Abengoa Bioenergy Corp.		
Christopher Standlee, Danny Allison		CO2 supply Colwich Ethanol Facility

## IMPACT

The project has been discussed in public venues – presentations at professional meetings, legislative committees, and town hall meeting, and has provided information on the project via the website to encourage a dialog on the merits and economies related to carbon management in Kansas. Kansans are realizing the potential for an important collaboration between the two of the largest economies in Kansas – agriculture and related ethanol industry and the petroleum industry to advance energy and contribute to a viable rural economy.

The small scale field test at Wellington Field as designed integrates two petroleum business activities: 1) use of CO2 for enhanced oil recovery and revitalizing many older mature oil fields and 2) disposal/storage of CO2 in the underlying saline aquifer for the longer term. It has been conveyed to the local petroleum industry that drilling and oil production infrastructure of an active oil field are important components that could lead to a successful carbon sequestration project including 1) knowledge about the subsurface including injection zones and caprock, 2) knowledge about abandoned wells, 3) access and suitability of land with greater likelihood for participation by landowner, and 4) access to insurance and investors to facilitate economic success.

## **CHANGES/PROBLEMS**

KGS is committed to starting BP2 on March 31, 2014 by finalizing contract with CO2 supplier, submitting Class II and IV applications. beginning field activities to inject CO2 into the Mississippian reservoir.

## **BUDGETARY INFORMATION**

### **Cost Status Report**

See next page for the cost status for quarters 1-9.



## Appendix A-1

### Drilling and Well Installation Plan

#### A-1.1 Introduction

A total of twenty three wells will be used to monitor pressures and track the CO<sub>2</sub> plume in the subsurface. The locations of these monitoring wells and the formations that they will monitor are shown in Figure A-1.1. Three monitoring wells will be located in the Arbuckle aquifer, six in the Mississippian system, two in the Chase Group underlying the Wellington Formation at the top, and twelve in the Upper Wellington Formation which is the lowermost (and only) Underground Source of Drinking Water (USDW) that is to be protected as a resource of potable water. Of the three Arbuckle wells, two (KGS #1-32 and Peasel-1) are existing wells. All six Mississippian wells are existing wells that will be retrofitted with gas sampling ports to collect casing head gas to detect and measure breakthrough or off-pattern migration of CO<sub>2</sub>. The remaining monitoring will be either new wells or retrofitted (Peasel-1) as summarized below:

Table A-1.1 Summary of new monitoring wells to be constructed/retrofitted at the Wellington CO<sub>2</sub> storage site.

<b>Geologic Formation</b>	<b>Number of new wells or wells to be reworked</b>
Upper Wellington Formation (USDW)	12 new wells
Chase Group (Immediately below USDW)	2 new wells
Arbuckle Group (Injection Zone)	1 new well (KGS #2-28) - 1 retrofitted (Peasel-1)

The well design and construction plans for the new monitoring wells, and the Peasel-1 Arbuckle well which is to be reworked are discussed below.

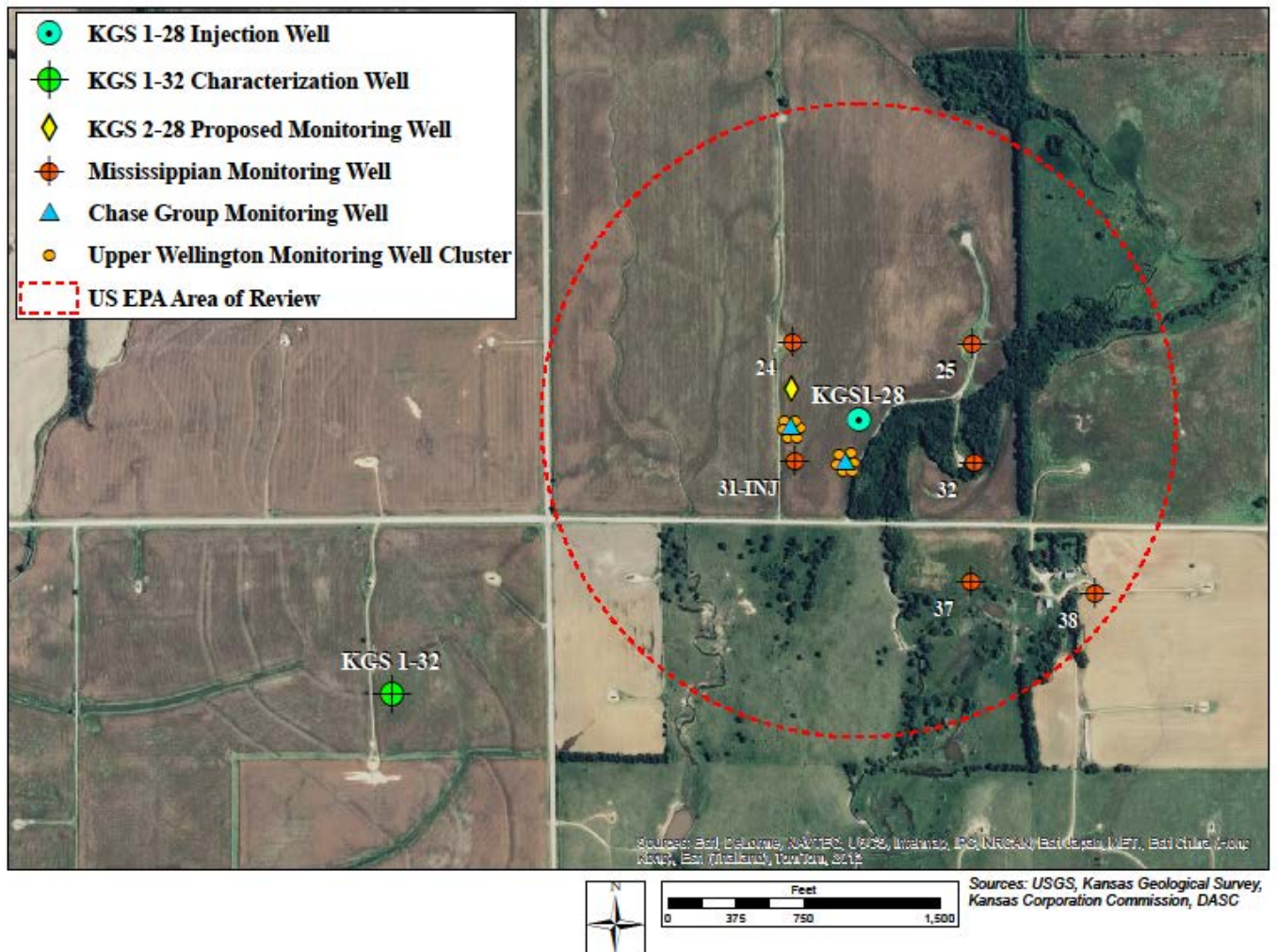

Figure A-1.1—Location of monitoring wells in the Arbuckle, Mississippian, and Wellington Formations.

## A-1.2 KGS #2-28 Arbuckle Monitoring Well

One new monitoring well (KGS #2-28) is to be constructed to monitor the CO<sub>2</sub> plume and pressure front in the Arbuckle Group. The well will be constructed approximately 350 feet up dip of the injection well KGS #1-28, and will be used to facilitate direct and indirect monitoring of both the pressure front and CO<sub>2</sub> plume in the Arbuckle. The well will be constructed in full compliance with EPA Class VI standards to ensure containment of CO<sub>2</sub>, and a full suite of geophysical logs will be obtained at the site. It is expected that the plume will reach this well in approximately 60–75 days after commencement of injection.

There is remarkable similarity in the geologic formations at existing Arbuckle well sites KGS #1-28 and KGS #1-32 which are located approximately 3,500 feet apart as shown in Figure A-1.1. Therefore, the geologic horizons at KGS #2-28 are also expected to be very similar to that at KGS #1-28. Hence, the proposed design of KGS #2-28, presented in Figure A-1.2, is very similar to the injection well, KGS #1-28. The well is expected to be approximately 5,200 feet deep, penetrating the top of the Pre-Cambrian granitic basement rock underlying the Arbuckle aquifer. The well will be perforated in the injection zone at approximately the same interval (4910-5050 ft, KB) as the injection well (KGS #1-28). The final depth and perforation interval however will be established on completion of drilling and will be specified in the well completion report. The wellbore trajectory will be monitored to ensure that the deviations are minimal.

#### **A-1.2.1 KGS #2-28 wellbore and casing**

The planned borehole and casing specifications at KGS #2-28 are shown in Table A-1.2 and Figure A-1.2. The conductor casing is expected to run between the surface and 125 feet. The surface casing, designed to provide a continuous cement sheath in order to fully isolate the USDW from the well, runs from the surface to a depth of approximately 650 feet, well below the lowermost USDW (Upper Wellington Formation) which is expected to be in the top 250 feet at the site. The production casing will be constructed from carbon and chrome steels and is expected to run from the surface to the bottom of the well. Corrosion of carbon steel casing is not expected during the life of this well. However, the potential for corrosion of casing material will be addressed by using CO<sub>2</sub>-resistant cement as discussed below, and the well will be also monitored for signs of corrosion.

**Wellbore Diagram**

LEASE Wellington KGS #1-28 API 15-191- 22590  
 NE SW SE SW Sec 28 31s - 1w Sumner COUNTY KANSAS

Perforate Arbuckle for CO2 Injection 4910' to 5050'

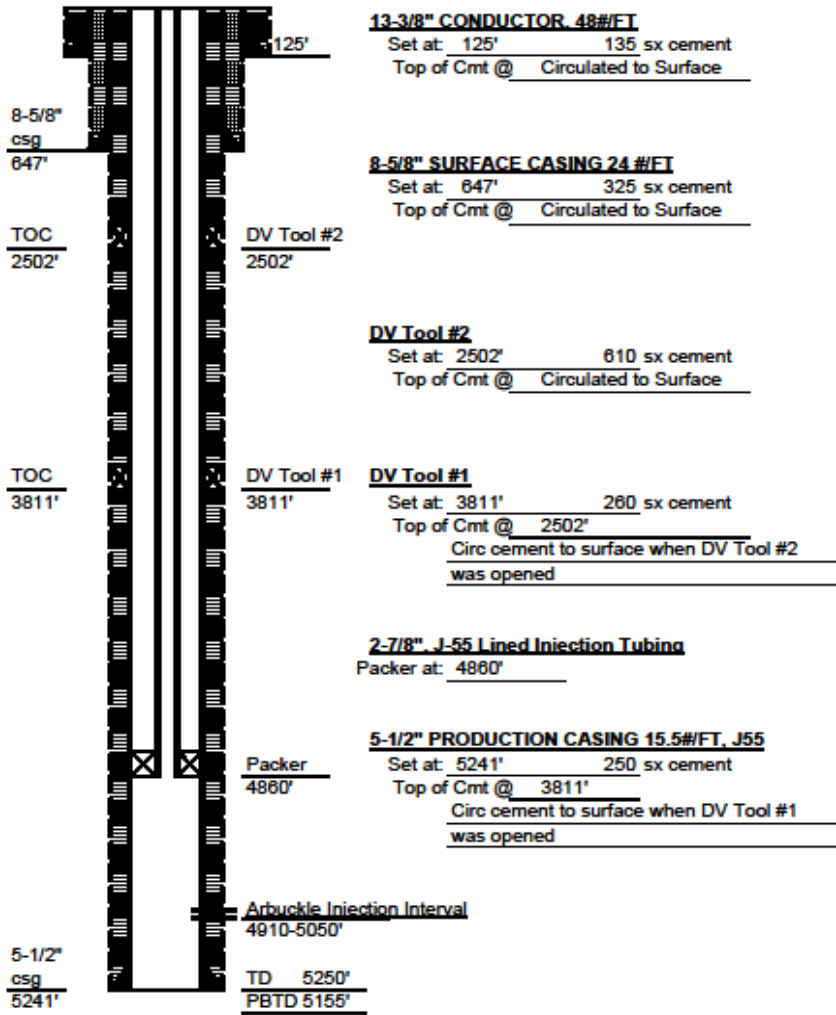

Wellington KGS #1-28-Wellbore Diagram  
 31 Date Printed: 12/20/11

Figure A-1.2—Schematic of the proposed Arbuckle monitoring well KGS #2-28.

Table A-1.2—Borehole and casing specifications at KGS #2-28.

Casing	Depth Interval (ft)	Borehole Diameter (inches)	Size OD/ID (in)	Weight (lb/ft)	Grade	Collapse Pressure (psi)	Burst Pressure (psi)	Tensile Yield (lbs)	Thread Yield (lbs)
Conductor	surface-125	17.5	13-3/8 and 12.615	54	J55	1,130	2730	853,000	514,00
Surface	surface- ~ 650	12.25	8-5/8 and 7.92	24	J55	1,370	2950	381,000	244,000
Production	surface- ~ 5300	7.875	5-1/2 and (4.892)	15.5	J55	4,040	4810	248,000	222,000

### A-1.2.2KGS #2-28 Tubing

The tubing will consist of a 2-7/8 inch steel string. It is expected to be approximately 5,000 ft long and weigh approximately 32,000 lbs which is substantially less the maximum allowable joint yield strength of approximately 72,580 lbs (Table A-1.3). This provides a safety margin at the uppermost joint of slightly over 40,000 lbs if one assumes the axial load is only being carried by that joint

Table A-1.3 —Tubing specifications at KGS #2-28.

Depth (ft)	Wall Thickness (inches)	Inside Diameter (inches)	Weight (lb/ft)	Grade (API)	Burst Strength (psi)	Collapse Strength (psi)	Joint yield strength (lb)
Surface - ~ 5,000	0.217	2.441	6.4	J55	7,260	7,680	72,580

There will be approximately 2 ½ inches of spacing between the production casing and the tubing, which is sufficient for work-over tools and conducting the testing and monitoring activities.

### A-1.2.3KGS #2-28 Cement

The conductor and surface casing cement job will be completed in a single stage. The cementing for the production casing will be accomplished in three stages using two DV tools at approximately 3,800 ft (DV #1) and 2,500 ft (DV #2) to ensure proper cement adherence (Figure A-1.2). The cement will be circulated to the surface by opening DV Tool #1 and DV Tool #2 during cementing of the lowest and middle stages respectively. The lower cement stage covers the entire Arbuckle formations. Centralizers are expected to be utilized to properly align the casing and to ensure that they are completed sealed.

As shown in Table A-1.4, common portland cement will be used to seal the space in the borehole for the conductor casings, and 60/40 POZ cement is to be used for the surface casing. For the conductor casing, CO2 resistant cement AA-2 will be used in the bottom stage, while a combination of AA-2 and (CO2 resistant) A-Con will be used in the middle stage, and AA-Con in the top stage. Note that the cement quantities specified in Table A-1.4 are estimates and may be adjusted as a result of hole conditions, final depths, etc.

Table A-1.4 Cement specifications for Arbuckle monitoring well KGS #2-28.

Purpose of String	Size Hole Drilled (inches)	Size Casing Set (inches)	Weight (lb/ft)	Setting Depth (bls, ft)	Type of Cement	Number of Sacks Used	Type and Percent Additives
Conductor	17.5	13.375	48	125	Common	135	3%cc, ¼# flake
Surface	12.25	8.625	24	App. 650	60/40 POZ	325	3%cc, ¼# flake
Production	7.875	5.50	15.5	App. 5300	AA-2	250	10% salt, 6 #gils, C-44
1 <sup>st</sup> DV Tool	7.875	5.50	15.5	App.3800	A-Con & AA-2	260	10% salt, 6 #gils, C-44
2 <sup>nd</sup> DV Tool	7.875	5.50	15.5	App.2500	A-Con	610	10% salt, 6 #gils, C-44

#### A-1.2.4 KGS #2-28 Geophysical Data Acquisition and Analyses

A modern suite of wireline logs such as “triple combo”, full-wave and sonic shall be acquired at the monitoring borehole to obtain necessary petrophysical information (i.e., porosity, saturation, sonic velocity, etc). The triple combo logs will include neutron density, gamma ray, caliper, SP, photo electric, and resistivity logs. Analysis of wireline logs will involve calibration with core measurements to predict porosity and permeability; estimation of rock mechanical properties from dipole sonic waveforms, and evaluation of formation invasion and resistivity to help in flow-unit identification.

The wireline data acquired at this site shall be integrated with log and core data from existing Arbuckle wells KGS #1-32 and KGS #1-28 in order to update the regional geomodel based porosity and permeability distributions in the Arbuckle aquifer, if necessary. Based on available budget, the following logs will be obtained:

- Array Compensated True Resistivity
- Drilling Time and Sample Log
- Temperature Log
- Compensated Spectral Natural Gamma Ray
- Microlog
- Spectral Density Dual Spaced Neutron Log
- Annular Hole Volume Plot
- Extended Range Micro Imager Correlation Plot
- Radial Cement Bond Log
- Composite Plot
- Magnetic Resonance Imaging Log

| The geophysical data will be used to establish the stratigraphy at the site and if it appears that the geologic formations at KGS #2-28 are offset with respect to KGS #1-28, then the perforation in the injection interval in the new monitoring well will be offset accordingly.

|

### **A-1.2.5 Borehole Testing**

#### **Drill Stem Test**

A Drill Stem Test (DST) shall be run across the injection interval to estimate formation hydrogeologic properties and to sample groundwater.

### **A-1.2.6 Demonstration of Mechanical Integrity**

Mechanical integrity tests shall be carried out at the monitoring borehole to ensure proper setting of the cement and to minimize the risk of leakage around the well bore. A cement bond log will first be obtained after setting and cementing the surface casing and long-string casing. A thermal log will also be acquired to ensure integrity of the cement and casing. The absence of temperature spikes in the log will indicate the absence of substantial leaks in the cement and/or casing. An annulus pressure test will be conducted to ensure that there are no leaks in the packer, tubing, and casing. The annulus will be monitored daily for leaks during injection by checking the fluid level in the annulus.

## **A-1.3 Peasel-1**

Peasel well-1 is a plugged and abandoned oil well located approximately 1,700 feet southeast of the injection well KGS #1-28 (Figure A-1.1). It was constructed on December 2, 1929 and drilled to a depth of 4,193 feet penetrating approximately 40 feet into the Arbuckle Group. It was plugged on September 30, 1947. It is to be redrilled and deepened for monitoring purposes; primarily pressure, as the CO<sub>2</sub> plume is not expected to reach this well.

### **A-1.3.1 Work Plan for Deepening Peasel-1**

The well will be recompleted in stages using Berexco's triple derrick workover rig and related equipment. The cement will first be drilled till a depth of 1,630 feet (top of 8-5/8 inch casing) using thin mud. The hole

will be cleaned completely. The drill bit will then be lowered to penetrate the top of the 8-5/8 inch casing and drilling continued to 3,240 feet where a cement plug will be placed. Drilling will resume to the top of the 7 inch casing at 3,270 feet and eventually till the bottom of the 7 inch casing at 3,670 feet. The cement in the 7 inch casing will be drilled out till bottom of the open hole at 4,193 feet (top of Arbuckle). An additional 300 feet of new hole will be drilled till a depth of approximately 4,500 feet. Open hole logs will be run from 4,500 ft to 3,670 ft, followed by installation of 4 ½ inch production casing till 4,500 feet and placing CO<sub>2</sub> resistant cement in the entire string from bottom to top. Preparation for completion and testing will commence thereafter by cleaning the site and mobilizing Berexco's completion rig and related equipment. The casing will be cleaned to total depth and pressure tested, followed by running gamma-ray neutron and cement bond log from surface to total depth. Select Arbuckle intervals will be perforated, and a 2-7/8 inch tubing installed.

**Plugged Wellbore Diagram**

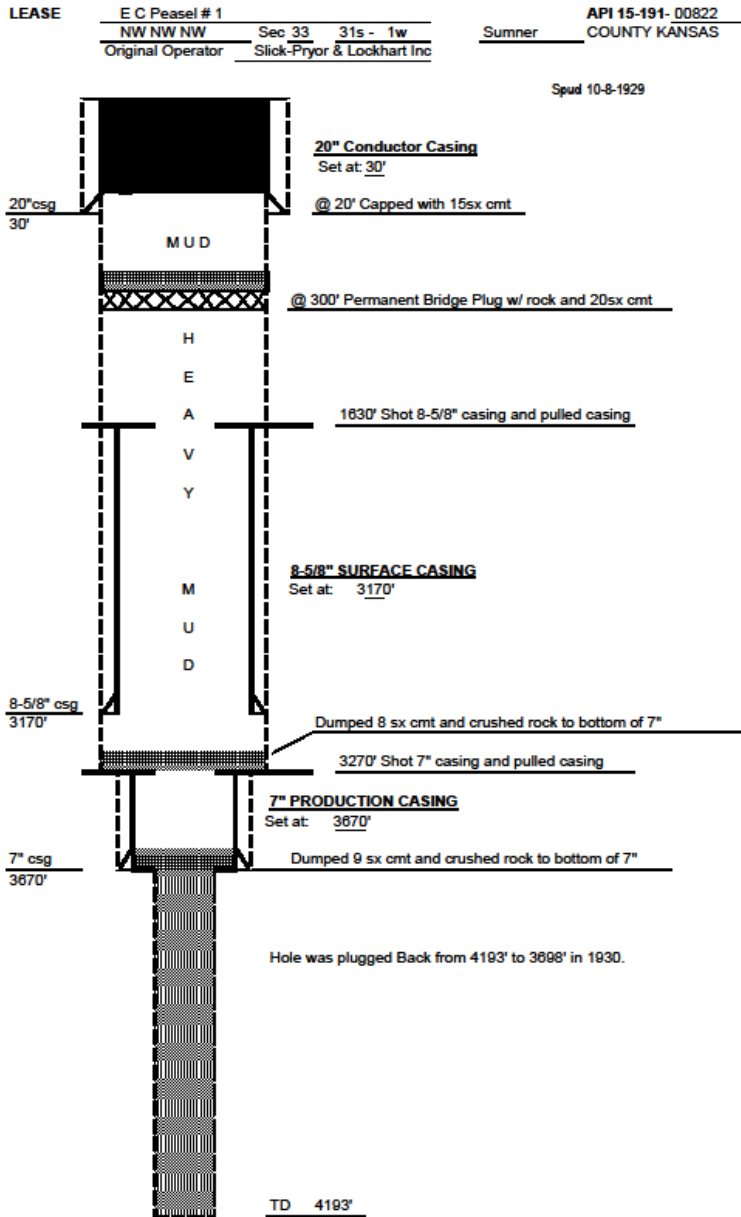

Wellbore Diagram - Peasel-1  
All Data Provided BY Slick

Figure A-1.3 well schematic of Peasel-1 showing construction details.

#### **A-1.4 Upper Wellington Formation (lowermost USDW) Monitoring Wells**

Two cluster of 2 inch PVC shallow wells (Figure A-1.1) will be installed in the in the Upper Wellington Formation, which is the lowermost USDW at the site. The well clusters are located in close proximity to the injection well so that any leakage through the confining zone is expected to be detected early in order to implement corrective measures. The Upper Wellington formation is present from near land surface to approximately 250 feet below ground at the injection well site. Groundwater movement at the site is primarily toward Slate Creek south of the site. The general dip of the geologic formations in the subsurface is to the northwest. Therefore, one cluster of wells is to be placed due south downstream of the injection well, and the second cluster is to be located west of the injection well. These sites are expected to intercept any plume that may potentially move in to the USDW. Both monitoring sites are located in close proximity to paved roads in the area, thereby providing easy access.

##### **A-1.4.1 Upper Wellington Well Design**

The six wells in each cluster will be completed at different depths depending on lithology at the site, but the top of the screen is expected to be placed at 20 ft, 40 ft, 60 ft, 80 ft, 100 ft, and 120 ft (Figure A-1.4). The final screen intervals will be established following drilling at the site. Each well in the cluster will be approximately 15 feet from an adjacent well and will be constructed of 2 inch (internal diameter) Schedule 40 PVC constructed in a 6-inch diameter boring, and gravel packed across a 10 to 20 ft interval depending on screen location and lithology which will be decided after completion of the drilling. The well will be fully grouted above and below the screened interval. Approximately 2-3 feet of bentonite seal will be placed on top of the gravel pack in order to assure a good seal before grouting. Each well will extend about 1 ½ feet above ground surface with a pressure tight cap which will have a cap with a hole for a ¼ inch tub and ½ inch access hole for tape. The wells will have a steel protective housing and a (3 ft x 3 ft) cement pad.

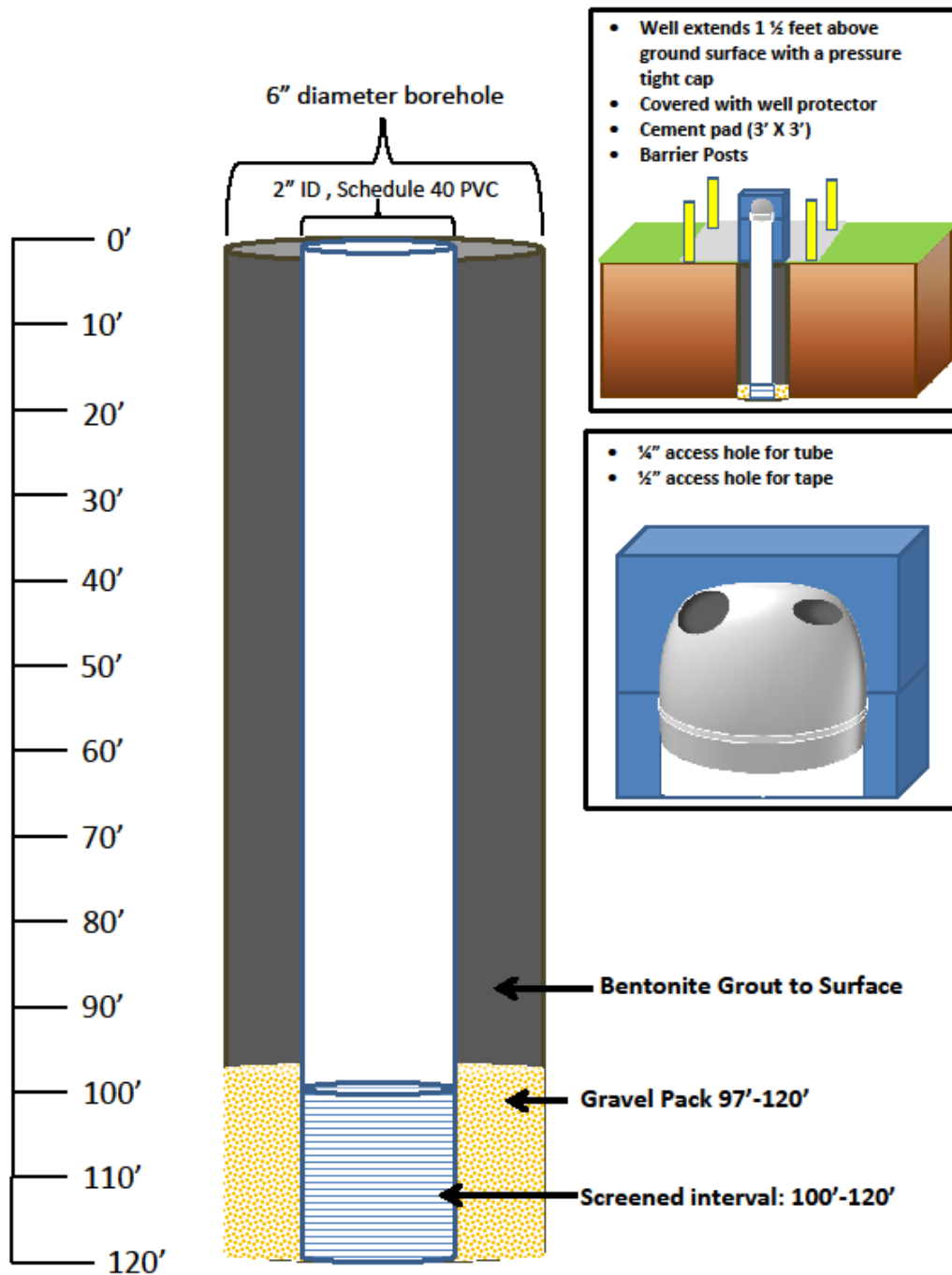

FigureA-1.4 —Typical schematic of Upper Wellington Formation monitoring well showing screened interval at 100-120 feet below land surface.

#### **A-1.4.2 Upper Wellington Borehole Logs**

Samples of soil in the Wellington Formation shall be collected and analyzed by X-ray diffraction to obtain major mineralogy. Samples in the USDW and the underlying salts/bedrock shall be collected during drilling to estimate soil porosity and permeability.

#### **A-1.5 Chase Group Monitoring Wells**

Because of its buoyancy, the injected CO<sub>2</sub> is expected to move upward from the injection zone if it breaches the multiple confining units above the Arbuckle. Therefore, two 5-inch PVC monitoring wells will be installed at the top of the Chase Group underlying the Wellington Formation at approximately 550 feet below ground for detecting CO<sub>2</sub>. As shown in Figure A-1.1, one of the well will be placed in the center of the Upper Wellington monitoring cluster south of the injection well, and the other will be located in the center of the Upper Wellington monitoring well cluster in the west. Both monitoring wells are located in close proximity to roads in the area.

##### **A-1.5.1 Well Design**

A typical schematic of the Chase monitoring well is shown in Figure A-1.5. The Chase Group wells will be screened throughout the upper 60 ft of the Chase Group. The final screen intervals will be selected following drilling at the site. Each well will be constructed of 5 inch (internal diameter) Schedule 40 PVC constructed in an 8 inch (or greater) wide borehole, and gravel packed throughout the screened interval. The well will be fully grouted from the top of the Chase Group to the surface. Each well will extend about 1.5 feet above ground surface with a pressure tight cap which will have a cap with a hole for a ¼ inch tub and ½ inch access hole for tape. The wells will have a well protector and a (3' x 3') cement pad.

##### **A-1.5.2 Borehole Logs**

Samples of soil and shallow bedrock shall be analyzed by X-ray diffraction to obtain major

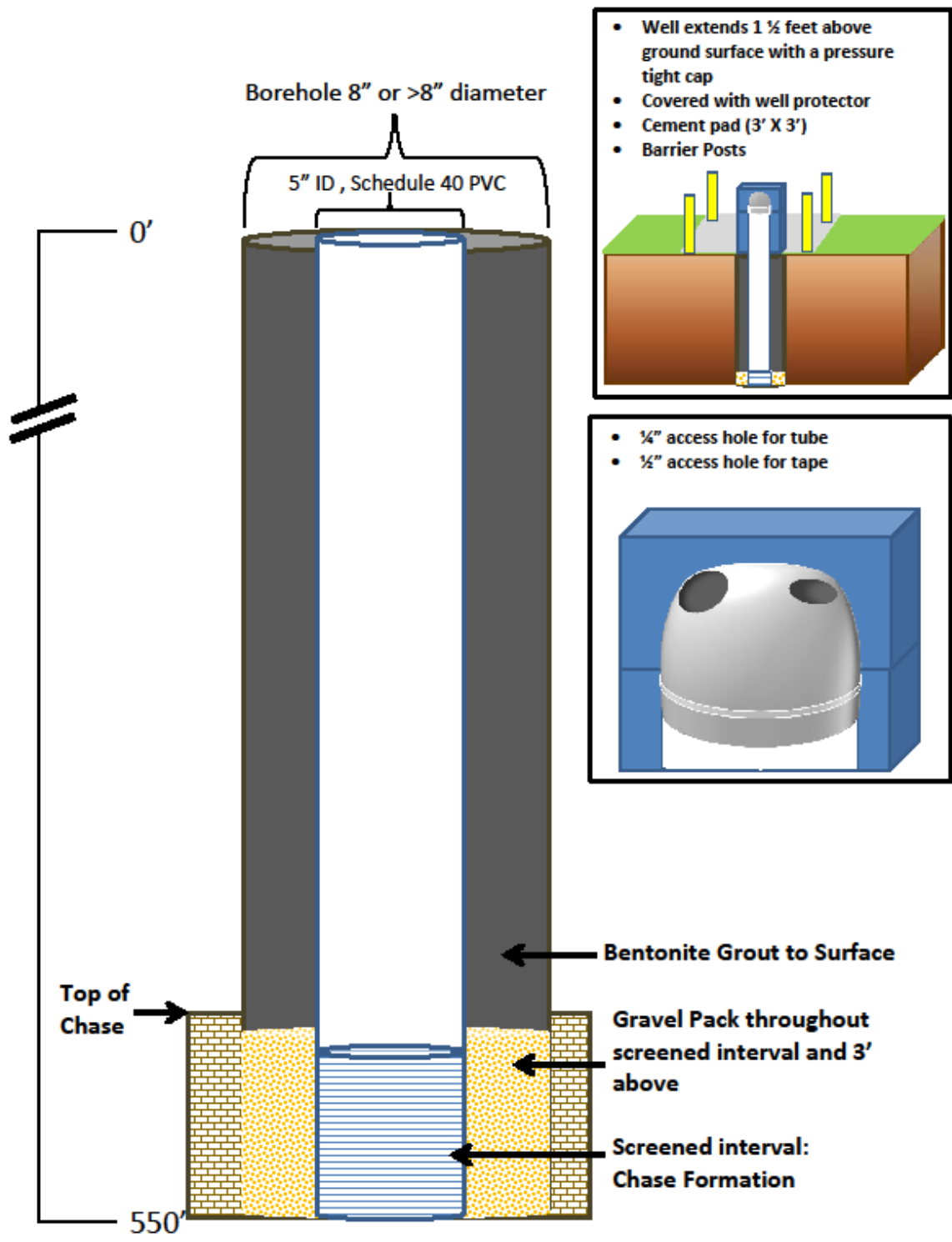

Figure A-1.5 Typical schematic of Chase Group monitoring well with estimated depth at 550 feet.

mineralogy. Samples of the evaporite cap rock shall be collected during drilling to determine the extent of porosity and permeability, and to assess approximate mineralogical changes via geochemical modeling (Geochemists WorkBench, SOLMINEQ and MINTEQA2).

## Appendix A-2

### Monitoring, Verification, and Accounting Plan

#### A-2.1 Introduction

The Monitoring, Verification, and Acceptance Plan for the Wellington project is developed to comply with EPA Class VI rule which requires the owner/operator to prepare, maintain and comply with a testing and monitoring plan to verify that geologic injection and storage of CO<sub>2</sub> is operating as permitted and is not endangering USDWs.

In addition to testing and monitoring at the injection well site (KGS #1-28), monitoring will also be conducted at the Arbuckle observation wells (KGS #2-28, KGS #1-32, and Peasel-1), six existing Mississippian wells above the primary confining zone, twelve new upper Wellington Formation (USDW) wells, and two new Chase Group wells at the base of the Wellington Formation (Figure A-2.1). The construction plans for the new Arbuckle, Wellington Formation and Chase Group monitoring wells is presented in Appendix A-1. Information about the six existing Mississippian wells chosen for monitoring purposes is presented in Section A-1.2. The MVA activities are described in sections A-2.3 to A-2.5. A schedule of the testing and monitoring activities prior to, during, and after injection are listed Table A-1.1.

Table A-1.1 List of monitoring activities to be conducted at the Wellington storage site.

Monitoring Activity	Pre-Injection	Injection	Post-Injection
CO <sub>2</sub> Fluid Chemical Analysis	x	x	-
CO <sub>2</sub> Injection Rate and Volume <sup>1</sup>	-	x	-
CO <sub>2</sub> Injection Pressure at Wellhead <sup>1</sup>	-	x	-
CO <sub>2</sub> Injection Pressure at Well Bottom <sup>1</sup>	x	x	x
Internal MIT (Annulus Pressure Test)	x	-	-
External MIT (Temperature Log)	x	x	x
Continuous Annular Pressure	-	x	-
Corrosion	-	x	x
Pressure Fall Off Test	x	-	-
Pressure in Arbuckle Monitoring Well (Direct Arbuckle Monitoring)	x	x	x
INSAR (Indirect Arbuckle Pressure Monitoring)	x	x	x
USDW Geochemistry	x	x	x
Mississippian Geochemistry	x	x	x
U-Tube (Direct Arbuckle Geochemistry Monitoring)	x	x	x

CASSM (Indirect Arbuckle Plume Front Monitoring)	x	x	x
Crosswell Seismic (Indirect Arbuckle Plume Front Monitoring)	x	x	-
3D Seismic Survey (Indirect Arbuckle Plume Front Monitoring)	x	-	x
<sup>1</sup> Monitored continuously			

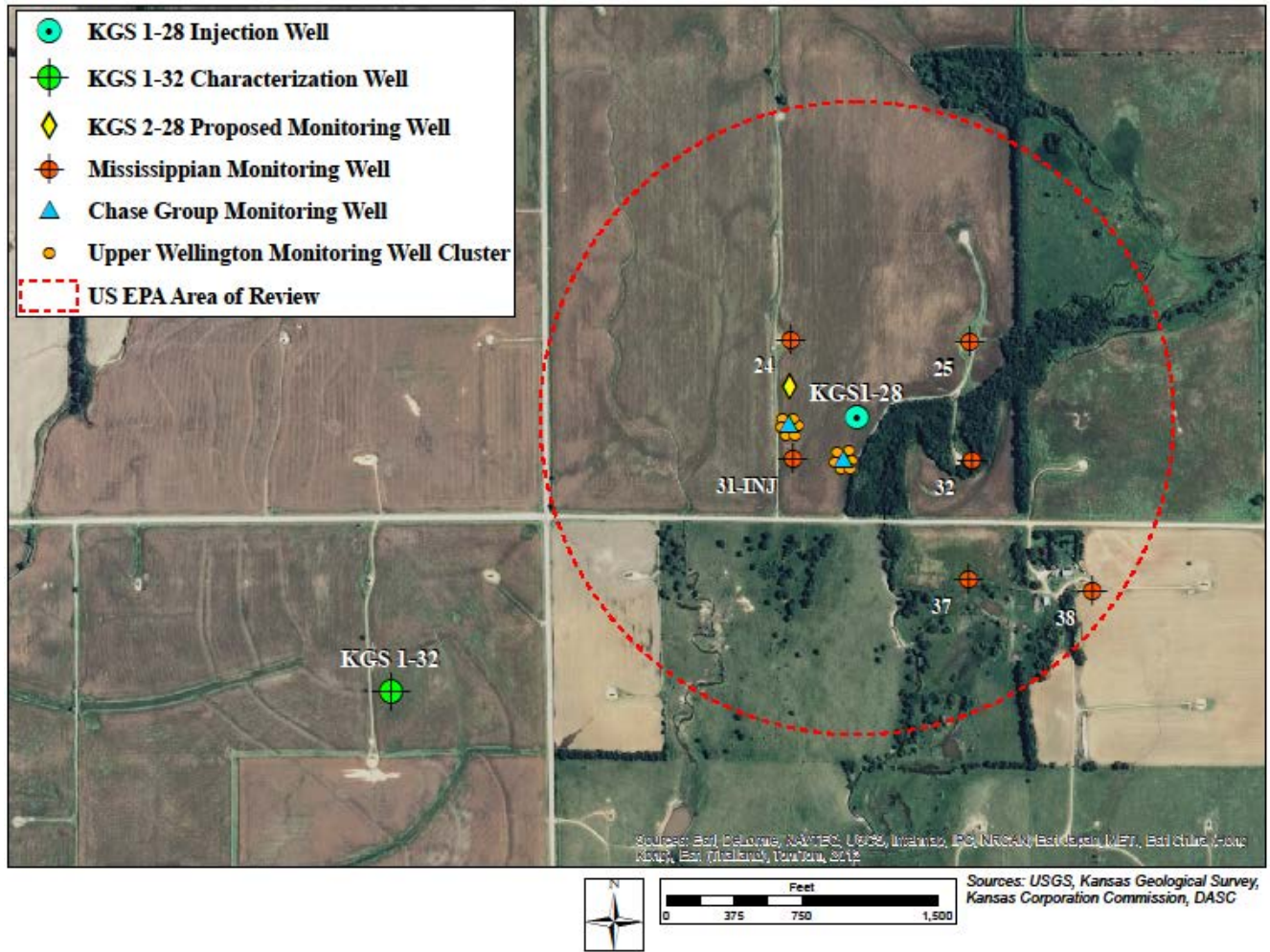

Figure A-2.1—Location of monitoring wells in the Arbuckle Group, Mississippian System, Chase Group, and Wellington Formation.

## A-2.2 Mississippian Monitoring Wells

There are several active oil wells around the CO<sub>2</sub> injection well, KGS #1-28, that are producing from the upper Mississippian formation above the Pierson Group, which is part of the upper confining zone. The locations of the Mississippian wells that will be used as monitoring wells are presented in Figure A-1.1. Well construction details of these two wells are presented in Table A-2.2. No geophysical logs are available for these wells in the KGS database.

Casing head gas and groundwater sampling of the Mississippian wells will be conducted during the pre-<sub>2</sub> injection phase to establish respective background (baseline) readings. Thereafter, water and casing head gas shall be sampled on a periodic basis during the injection and post-injection phases, analyzed, and compared with the baseline survey data to detect the presence of CO<sub>2</sub> in the Mississippian Reservoir

Table A-2.2 Well data for Mississippian wells to be used for CO<sub>2</sub> monitoring.

API Well Number	Lease Name	Well Class	Operator Name	Total Depth	Status	Spud Date	Completion Date	API Number	Elevation (ft, msl)	NAD83 Latitude	NAD83 Longitude
10045	WELLINGTON UNIT, was KAMAS 6	Producing	Sinclair Prairie Oil	3678	OIL	2/1/36	10/1/36	15-191-10045	1246	37.31883	-97.4316
10106	ERKER	Spudded	STELBAR OIL CORP	3680	OIL	11/17/36	12/16/36	15-191-10106	1235	37.31708	-97.43459
10055	WELLINGTON UNIT, was FRANK KAMAS 9	Producing	Sinclair Prairie Oil	3707	OIL	12/14/36	10/1/37	15-191-10055	1264	37.32071	-97.43501
10054	WELLINGTON UNIT was Kamas 7	Producing	Sinclair Prairie Oil	3681	OIL	3/26/36	10/1/88	15-191-10054	1258	37.32064	-97.4316
22590	WELLINGTON KGS 1-28	Inactive Well	BEREXCO LLC	5250	CO2 Injection	2/20/11	8/24/11	15-191-22590	1257	37.31951	-97.43378
10051	FRANK KAMAS	Recompleted	Sinclair Prairie Oil	3704	OIL	12/30/35	10/1/36	15-191-10051	1257	37.3189	-97.43501

## A-2.3 Testing and Monitoring at Injection Well Site

### A-2.3.1 Carbon Dioxide Stream Analysis

The Class VI Rule requires that the injected carbon dioxide stream be analyzed with sufficient frequency to yield data representative of its chemical and physical characteristics. Monitoring the chemical composition is accomplished to verify that the injectate does not qualify as hazardous waste with regard to corrosivity or toxicity, as well as to ensure that the delivered carbon dioxide stream meets the specifications outlined in the EPA permit. The monitoring plans are presented below. Small quantities of

SF6 and Kr (Krypton) shall be periodically co-injected with CO2 to facilitate estimation of the travel time between injection and monitoring wells.

#### ***A-2.3.1.1 Sampling Location and Method***

The CO<sub>2</sub> stream is expected to be composed of high purity (99+ %) CO<sub>2</sub>. The CO<sub>2</sub> will be delivered at near atmospheric pressure. After collection at the plant, the CO<sub>2</sub> will be dehydrated and compressed to a liquid state at temperature and pressure of approximately -10°F and 350 psi and transported in trucks to the site for injection. Carbon dioxide injectate samples will be collected immediately upstream of the injection well head in a lined sample bottle and transported to a National Environmental Laboratory Accreditation Program (NELAP) accredited laboratory for analysis.

#### ***A-2.3.1.2 Fluid Analysis***

The exact chemical composition of CO<sub>2</sub> will be ascertained prior to injection once the CO<sub>2</sub> source has been finalized. The CO<sub>2</sub> stream is expected to have high levels of CO<sub>2</sub> with only trace levels of other constituents or impurities such as nitrogen, oxygen, methanol, acetaldehyde and hydrogen sulfide. The analytical suite will be established when the first pre-injection sample is collected and at a minimum, will include nitrogen, oxygen, methanol, acetaldehyde, and hydrogen sulfide. The samples will be analyzed using standardized ASTM procedures for gas chromatography, mass spectrometry, detector tubes, and photo ionization. The sample will be tested using ASTM 5954, ASTM 6228, ASTM 5504 or equivalent procedures. For permitting purposes, it is proposed that the CO<sub>2</sub> stream will not exceed the minimum specification specified in Table A-2.3.

Table A-2.3 Minimum CO<sub>2</sub> Stream Acceptance Specifications

<b>Component</b>	<b>Quantity</b>
CO <sub>2</sub>	97% dry basis
Inert Constituents	1%

Trace Constituents	2%
Oxygen	<20 ppm
Total Sulphur	< 25 ppm
Arsenic	< 5 ppm <sup>a</sup>
Selenium	< 1 ppm <sup>a</sup>
Mercury	< 2 ppb <sup>b</sup>
Hydrogen Sulfide	< 20 ppm
Water Vapor	< 30 lb/mm scf
(a) Resource Conservation and Recovery Act (RCRA) standard	
(b) Safe Drinking Water Act standard	

Carbon dioxide grab samples will be collected immediately upstream of the well head in a pre-cleaned lined sample bottle and transported to a National Environmental Laboratory Accreditation Program (NELAP) accredited laboratory for analysis. The bottle will be flushed with inline CO<sub>2</sub> prior to sample collection, labeled, and transported to the laboratory in accordance with EPA guidelines. A Chain of Custody form will document:

- <sup>a</sup> Sampling date
- Analytical detection limit
- Location of the sample
- Type of container
- Sampler name and signature
- Other comments/notes
- Shipping information (name, address, and point of contact at laboratory, including phone number).
- Name and signature of personnel involved in the chain of custody.

The laboratory report will include the analytical results as well as detection limits established for the method employed to detect each chemical constituent presented in Table A-2.3.

#### **A-2.3.1.3 Sampling Frequency**

The CO<sub>2</sub> will be sampled at five periods: prior to commencement of injection, once each month for the first three months of injection, and again six months following commencement of injection. Injection is to cease at the end of nine months of operation. If there is significant variation in the quarterly sample results, then a final sample will be collected and analyzed at the end of the injection period (9 months).

#### **A-2.3.1.4 Quality Assurance/Quality Control**

The samples will be analyzed using standardized ASTM procedures for gas chromatography, mass spectrometry, detector tubes, and photo ionization. The sample will be tested using ASTM 5954, ASTM 6228, ASTM 5504 or equivalent procedures. The sample integrity and security will be documented through maintenance of a field sampling record and a Chain of Custody form as described above. The laboratory report will provide documentation of instrument calibration, analytical results, and detection limits established for methods employed. For data validation purposes, the following samples will be analyzed with each batch of collected samples:

- One or two field duplicates
- One equipment rinsate
- One matrix spike (when appropriate for the analytical method)
- One trip blank

#### **A-2.3.2 Continuous Recording of Operational Parameters**

##### **A-2.3.2.1 Continuous Monitoring of Injection Rate/Volume**

The Class VI Rule requires the installation and use of continuous recording devices to monitor injection rate and volume. The monthly average, maximum, and minimum values will be reported in semi-annual reports to the EPA. This information will be used to verify compliance with the operational conditions of the permit and to assist in AoR reevaluations.

The injection rate will be continuously monitored using the Orifice-Plate differential meter which uses Bernoulli's equation to determine flow by measuring the pressure drop across a plate with a hole. It is the standard flow measuring device in the oil and gas industry and typically achieves an accuracy of two to four percent of the full scale reading. The mass rate will be calculated using the CO<sub>2</sub> density which will be calculated using equations of state and pressure and temperature readings. Cumulative injection volume and mass will be continuously calculated and reported in semi-annual reports. It should also be noted that since the CO<sub>2</sub> will be transported to the site via trucks, which will be weighed, an indirect measurement of the CO<sub>2</sub> mass will also be available.

#### **A-2.3.2.2 Continuous Monitoring of Injection Pressure**

The Class VI Rule requires the installation and use of continuous recording devices to monitor injection pressure. Injection pressure will be measured at both the wellhead and the center of the perforations in the injection zone (bottom hole pressure). Bottom hole pressure is equal to wellhead pressure plus the hydrostatic pressure that exists due to the weight of the fluid column between the wellhead and bottom hole, minus frictional losses. The two sources of pressure data will therefore be used to check the accuracy of the individual pressure measurements. Injection pressure is monitored to ensure that the fracture pressure of the formation and the burst pressure of the well tubing are not exceeded and that the owner or operator is in compliance with the permit. A standard oil-filled pressure gauge will be installed at the wellhead, and a pressure transducer will be placed near the perforation to monitor the bottom hole pressure.

#### ***A-2.3.2.3 Continuous Monitoring of Temperature***

Surface and bottom hole temperature will be monitored continuously in the injection well using the same data logger that measures pressure in order to fulfill EPA's injection well operating requirements.

#### **A-2.3.2.4 Continuous Monitoring of Annulus Pressure and Volume**

Since a waiver will be sought from pressurizing the annulus due to low injection pressures, continuous monitoring of the annulus will involve a daily inspection of the water level in the annulus. A rise or drop in water level of beyond the range expected due to thermal expansion/contraction will be considered a failure of the internal MIT triggering a system wide shut-off, which will halt injection immediately and limit the amount of leakage. The shutoff will be reported to the EPA within 24 hours. The cause(s) of the pressure drop will be investigated to identify the location of leakage and repair the well. An Annulus Pressure Test will be conducted following investigation/remediation to ensure well integrity.

#### ***A-2.3.2.5 Operating Range for Key Injection Parameters***

- CO<sub>2</sub> Injection Flow Rate: 150 metric tons/day (+/- 5%)
- Wellhead Inlet Pressure: < 1,500 psig
- Bottom hole Pressure: < 2,636 psig @ 5,050 ft
- Annulus Pressure at Surface: 0 psig
- Wellhead CO<sub>2</sub> Temperature: -10° to +30° F
- Bottom Hole CO<sub>2</sub> Temperature: 10 - 70° F @ 5,050 ft

### **A-2.3.3 Corrosion Monitoring**

The Class VI Rule requires quarterly monitoring of well materials for corrosion in order to detect loss of material in the casing, tubing and packer which may compromise the mechanical integrity of wells. However, due to the short period of injection (nine months), corrosion is not expected to occur in the Wellington injection or observation wells.

#### ***A-2.3.3.1 Corrosion Detection Method and Sampling***

Corrosion coupons will be used for monitoring loss of material in the injection well. Coupons are very simple to use and analyze, and they provide a direct measurement of material lost to corrosion. Two pre-weighed, dimensionally measured, and photographed coupons made of representative injection well construction material will be placed in the flow line and the wellhead. These coupons will be removed every quarter, cleaned and reweighed. The samples will be visually inspected under magnification for loss of mass, thickness, cracking, pitting, or other signs of corrosion.

The average corrosion rate in the well will be calculated from the weight loss of the coupon. The coupon will be weighed to an accuracy of +/- 0.1 of a milligram. The weight will be used to calculate the corrosion rate in mils/year, where a mil is equal to a thousandth of an inch. If the coupons are found to have more than 3 mils/year of loss, corrective action will be taken in consultation with the EPA Region 7 Director and the coupons will be monitored more frequently. However, as mentioned above, no corrosion of the well material is expected given the short duration of injection.

#### ***A-2.3.3.2 Corrosion Reporting***

Dimensional and mass data, along with a calculated corrosion rate (in mils/yr), will be submitted to the EPA Program Director every six months in semi-annual reports which will include the following information:

- A description of the corrosion monitoring technique;
- Measurement of mass and thickness loss from corrosion coupons;
- Assessment of additional corrosion, including pitting, in the corrosion coupons and the overall corrosion trends;
- Any necessary changes to the project Testing and Monitoring Plan to continue protection of USDWs.

### **A-2.3.4 Mechanical Integrity Testing**

Internal and external Mechanical Integrity Tests (MITs) will be conducted prior to, during, and following injection. Internal tests will be conducted to ensure the absence of any leaks in the injection tubing, packer or casing, and external tests will be conducted to ensure the absence of any leaks through channels adjacent to the wellbore that may result in significant fluid movement into a USDW. The Class VI Rule requires that internal mechanical integrity be demonstrated continuously during injection, and external MIT be conducted prior to injection, at least once per year during the injection phase, and prior to injection well plugging after the cessation of injection.

#### **A-2.3.4.1 Internal MIT with Annulus Pressure Test**

Prior to commencing injection, an Annulus Pressure Test will be conducted at the injection well KGS 1-28 in order to demonstrate internal MIT. The test will provide information necessary to determine whether there is a failure of the casing-cement bond, injection tubing, and packers.

The test will consist of pressurizing the corrosion resistant fluid of the annulus and then isolating the annular space from the source of pressure by a closed valve, or by disconnecting the pressure source entirely. Pressure measurements taken during isolation of the annulus will be analyzed for any change in pressure in order to detect leakage. Because the annulus exchanges heat with its surroundings, small pressure changes that are not due to leakage may occur during the test.

After the test period, the valve to the annulus will be opened and amount of returned fluid measured in a container. This will be a confirmatory exercise to determine whether the full length of the annulus was tested as the amount of captured liquid should be in conformance with the size of the annulus and the test pressure. The data obtained, including recorded charts from the tests and volume of liquid used, shall be submitted to the EPA within 30 days of test completion.

Failure of the pressure to stabilize within a range of 5 percent of the injection pressure will constitute a failure to demonstrate mechanical integrity. If this occurs, the causes of the pressure

drop will be investigated and corrective measures implemented as necessary. An Annulus Pressure test will be conducted following any well remediation activities in order to confirm well integrity.

#### **A-2.3.4.2 External MIT Using Temperature Logs**

A temperature log will be used to demonstrate external MIT in the injection well (KGS 1-28), and its use is based on the principle that fluid leaking from the well will cause a temperature anomaly adjacent to the wellbore. The log will be obtained from the surface to the bottom of the well using a wireline logging tool.

Temperature logs will be obtained prior to commencement of injection, after 6 months of injection, and prior to closure of the site. The pre-injection log, along with the temperature log obtained during well construction, will serve as a baseline for the subsequent monitoring during the injection and post injection phases.

The well will be shut during the injection phase for a period of 36 hours prior to obtaining the temperature log. During the shut-in period, the temperature within the wellbore will typically migrate towards ambient geothermal conditions, but will not fully equilibrate to ambient conditions. If there has been a leak of fluid out of the well, the temperature within the wellbore at this location will change to a lesser extent and be measured as an anomaly because the temperature of the surrounding formation will have been modified by the leaking fluid.

Leaks will be identified from injection and post-injection logs by noting relative differences between the collected temperature log and the baseline (and previous) logs. Since lithology and injectate characteristics will be similar, the thermal effects along the wellbore are expected to be very similar. After the temperature effects caused by injection, casing joints, packers, well diameter, casing string differences and cement have dissipated, the temperature profiles are expected to be similar, although not identical. The log and associated report will be submitted to the EPA within 30 days of test completion. If interpretation of the data indicates a noncompliance, a report will be submitted to EPA within 24 hours of testing. If necessary, radioactive tracer, noise, oxygen activation or other logs approved by the EPA Program Director may be used to further define the nature of the fluid movement.

#### **A-2.3.5 Pressure Fall-Off Testing**

The Class VI Rule requires pressure fall-off testing of the injection well prior to commencing injection and at least once every five years. Pressure fall-off tests are used to measure formation properties in the vicinity of the injection well. The objective of periodic testing is to monitor for any changes in the near-wellbore environment that may impact injectivity and pressure increase. Anomalous pressure drops during the test may also be indicative of fluid leakage through the wellbore.

A pressure fall-off test will be conducted prior to commencement of injection at the Wellington site. However, a pressure fall-off test following commencement of injection is not proposed for this project because, a) injection is to occur for a short period of 9 months, b) extensive testing/monitoring to track the carbon dioxide plume will be performed, and c) the site is expected to close within 5 years of commencement of injection.

A steady rate of water flow will be maintained during the injection phase of the Pressure Fall-Off test. This will be followed by a shut-in period, the duration of which will be determined on the site in order to obtain sufficient transient response for analyzing the data. The bottom hole pressure will be continuously recorded during the entire test by pressure transducers for a sufficient period to make valid observation of a pressure fall-off curve. Pressures will be measured at a frequency that is sufficient to measure the

changes in bottom hole pressure throughout the test period, including rapidly changing pressures immediately following cessation of injection. The magnitude of the bottomhole pressure will be adjusted so as to not exceed 90% of the fracture gradient.

**A-2.4 Groundwater Geochemical Monitoring Above the Confining Zone**

Groundwater quality in the USDW (Upper Wellington Formation), the Chase Group, and the upper Mississippian System above the confining zone will be directly monitored. The location of the Mississippian and USDW monitoring wells are presented in Figure A-2.1. All monitoring wells presented in Figure A-2.1 are located in close proximity to paved roads and fully accessible by a truck. Berexco is the operator of the Wellington oil field and has permission to physically monitor all well sites.

Baseline data will be collected from the monitoring wells prior to injection and monitoring will be conducted as per the schedule presented in Table A-2.4 below. An increase in the concentration of dissolved carbon dioxide will indicate the presence of separate-phase or dissolved-phase carbon dioxide. The concentration of carbon dioxide will be used to ascertain if separate-phase carbon dioxide may be present, based on accepted mass-transfer relations and equilibrium constants.

**A-2.4.1 Monitoring Wells Above the Confining Zone: Sampling Frequency, Analytical Suites, QA/QC, and Reporting Requirements**

**A-2.4.1.1 Mississippian Wells**

Gas sampling ports shall be installed in the two existing Mississippian wells shown in Figure A-2.1 in order to collect head gas to detect and measure amount of early breakthrough or off pattern migration of CO<sub>2</sub>. These two wells will be sampled 3 times prior to injection in order to establish baseline CO<sub>2</sub> concentration. The analytical suite to be monitored and the monitoring frequency is presented in Table A-2.4 below for monitoring wells within and above the injection zone. Produced water and casing head gas shall be sampled, analyzed, and compared with the baseline survey data to determine the presence of CO<sub>2</sub> and other parameters in the Mississippian Reservoir. The (inorganic) indicator parameters are known to be associated with chemical reactions in the presence of CO<sub>2</sub> and therefore expected to provide information regarding the presence of the injectate in the hydrogeologic formations. The sampling and testing will continue every 3 months during the post injection phase.

Table A-2.4 Geochemical analytical suite to be monitored in the Mississippian, Chase, and Upper Wellington (USDW) wells at the Wellington site.

Field Parameters	Pre-Injection	During injection	Post-Injection
pH	Once a week for 3 weeks	Every 3 months	Every 6 months

Specific Conductivity	Once a week for 3 weeks	Every 3 months	Every 6 months
Temperature	Once a week for 3 weeks	Every 3 months	Every 6 months
Dissolved Oxygen	Once a week for 3 weeks	Every 3 months	Every 6 months
Gas-Water Ratio	Once a week for 3 weeks	Every 3 months	Every 6 months
Depth to Water	Once a week for 3 weeks	Every 3 months Every 3 months	Every 6 months
TDS/Salinity	Once a week for 3 weeks	Every 3 months	Every 6 months
<b>Indicator Parameters</b>			
Alkalinity	Once a week for 3 weeks	Every 3 months	Every 6 months
Bromide	Once a week for 3 weeks	Every 3 months	Every 6 months
Calcium, Iron, Magnesium, Potassium um, Dissolved Silica	Once a week for 3 weeks	Every 3 months	Every 6 months
Chloride	Once a week for 3 weeks	Every 3 months	Every 6 months
Sodium	Once a week for 3 weeks	Every 3 months	Every 6 months
Total CO <sub>2</sub>	Once a week for 3 weeks	Every 3 months	Every 6 months
Total Fe	Once a week for 3 weeks	Every 3 months	Every 6 months
Total Fe (II)	Once a week for 3 weeks	Every 3 months	Every 6 months
Total NH <sub>4</sub> <sup>+</sup>	Once a week for 3 weeks	Every 3 months	Every 6 months
Total NO <sub>3</sub> <sup>2-</sup>	Once a week for 3 weeks	Every 3 months	Every 6 months
Total SO <sub>4</sub> <sup>2-</sup>	Once a week for 3 weeks	Every 3 months	Every 6 months
Total PO <sub>4</sub> <sup>3-</sup>	Once a week for 3 weeks	Every 3 months	Every 6 months
Total HCO <sub>3</sub> <sup>-</sup>	Once a week for 3 weeks	Every 3 months	Every 6 months
Total CO <sub>2</sub>	Once a week for 3 weeks	Every 3 months	Every 6 months

<b>Concentration of Organics</b>			
DOC	Once a week for 3 weeks	Every 3 months	Every 6 months
TOC	Once a week for 3 weeks	Every 3 months	Every 6 months
DIC	Once a week for 3 weeks	Every 3 months	Every 6 months
<b>Stable Isotopes</b>			
$\delta^{18}O$	Once a week for 3 weeks	Every 3 months	Every 6 months
$\delta D$	Once a week for 3 weeks	Every 3 months	Every 6 months
$\delta^{13}C$ for Carbonates in System	Once a week for 3 weeks	Every 3 months	Every 6 months

#### 10.4.1.2 Upper Wellington Formation (USDW)

Samples shall be collected prior to injection. This information will constitute baseline data for future comparison during the injection and post-injection phases. The different constituents that are to be tested during the injection phase, and the testing frequency is provided in Table A-2.4. Water quality parameters shall be repeatedly checked for any changes with time for ph, conductivity, alkalinity, DO and redox values. During the post-injection period, the same tests described above for the injection period will be conducted periodically. The sampling frequency may be increased if the results of monitoring indicate possible fluid leakage or endangerment of USDWs.

#### 10.4.1.3 Sampling and Analysis Procedures and Quality Assurance/Quality Control (QA/QC)

The following sampling, handling, and analyses QA/QC procedures will be followed to ensure the acquisition of high quality data:

- Static water levels in the USDW (Upper Wellington) will be determined using an electronic water level indicator before any purging or sampling activities. Dedicated pumps (e.g., bladder pumps) will be installed in each monitoring well to minimize potential cross contamination between wells and minimize the introduction of atmospheric CO<sub>2</sub>.

- Each USDW (Upper Wellington) monitoring well will be purged using a submersible pump, or the samples obtained using a low flow sampling technique. Samples will be field preserved as required by the analytical method.
- The pumps, tubing, and any other downhole accessories will be rinsed with deionized water and placed in bags for travel to the field site. During pump deployment and at other times, care will be taken to ensure that equipment to be used inside the monitoring wells remains clean and does not come in contact with potentially contaminating materials.
- All field and downhole equipment will be properly calibrated according to the manufacturer specifications.
- Exposure of the samples to ambient air will be minimized.
- Groundwater pH, temperature, specific conductance, and dissolved oxygen will be monitored in the field using hand held portable probes.
- For data validation purposes, the following samples will be analyzed with each batch of collected samples:
  - One or two field duplicates, sometimes triplicates, depending on the accuracy of instruments provided to analyze the waters
  - One equipment rinsate
  - One matrix spike (when appropriate for the analytical method)
  - One trip blank
- A chain-of-custody record shall be completed and accompany every sample. All sample bottles will be labeled with durable labels and indelible markings. A unique sample identification number, sampling date, and analyte(s) will be recorded on the sample bottles as well as sampling records written for each well. Sampling records (e.g., a field logbook, individual well sampling sheet) will indicate the sampling personnel, date, time, sample location/well, unique sample identification number, collection procedure, measured field parameters, and additional comments as needed.
- Where appropriate, ASTM Method D6911-03 (2003) will be followed for packaging of samples. Immediately upon sample collection, containers shall be placed in an insulated cooler and cooled

to 4 degrees Celsius. Upon receipt at the Kansas State laboratory, the samples will be accepted and tracked by the laboratory from arrival through completed analysis.

- All groundwater quality results will be entered into a database or spreadsheet with periodic data review and analysis.

#### ***A-2.4.1.4 Groundwater Quality Data Reporting***

The following information will be submitted with all quarterly and semi-annual monitoring reports to the EPA:

- The most up-to-date historical database of all ground water monitoring results,
- Interpretation of any changing trends and evaluation of fluid leakage and migration. This may include graphs of relevant trends and interpretative diagrams,
- A map showing all monitoring wells, indicating those wells that are believed to be in the location of the separate-phase carbon dioxide plume,
- The date, time, location, and depth of all ground water samples collected and analyzed,
- Copies of laboratory analytical reports,
- A description of sampling equipment,
- Chain of custody records,
- The name and contact information for the laboratory manager at Kansas State University,
- Identification of data gaps,
- Presentation, synthesis and interpretation of the entire historical data set,
- Documentation of the monitoring well construction specifications, sampling procedure, laboratory analytical procedure and QA/QC standards.

#### **A-2.5 Carbon Dioxide Plume and Pressure Front Tracking**

Identification of the position of the injected CO<sub>2</sub> plume and the presence or absence of elevated pressure (i.e., the pressure front) is integral to protection of USDWs for Class VI projects. Monitoring the movement of the carbon dioxide and the pressure front is necessary to both identify potential risks to USDWs posed by injection activities and to verify predictions of plume movement in order to ensure that the plume is adequately confined. Monitoring movement of the plume and the pressure front also provides necessary data for comparison to model predictions, and inform reevaluation of the AoR. Both direct and indirect measurement methods will be used to monitor the movement of the pressure and plume fronts as discussed in the following sections.

#### **A-2.5.1 Monitoring Pressure Front**

The Class VI Rule requires that fluid pressure be directly monitored within the injection zone. This type of monitoring provides observations of increases in formation pressures and support tracking the migration of the pressure front.

##### ***A-2.5.1.1 Direct Arbuckle Pressure Monitoring***

Pressure transducers in the injection zone will be installed in the Arbuckle monitoring well KGS #2-28 and the injection well (KGS #1-28). The transducers will record pressures continuously every 30 seconds in both the injection and monitoring wells. The system will have a battery backup or alternative power supply to ensure continued collection of data during power failures. The electronic data from the continuous recorder will be stored on multiple sources of data storage media for redundancy. The data will be backed up on an electronic media storage device. There will be a separate alarm system that will monitor surface and bottom hole pressures in the injection well and trigger a system shutoff and notification to Berexco if a violation of the injection pressure limits occurs.

Pressure time series at each Arbuckle monitoring and the injection well will be constructed and used to monitor the growth of the pressure front. Spatial patterns will also be analyzed by constructing maps that represent contours of pressure. The pressure data will be compared with model based prediction of the pressure front, and if necessary, the simulation model will be recalibrated to conform to field data. The EPA Program Director will be kept updated of pressure observations via quarterly reporting of the pressure time series, and will also be consulted during model reevaluation if warranted by the data. Based on modeling results, the pressure in the Arbuckle are expected to stabilize to nearly pre-injection levels within 2 months of cessation of injection. Therefore, the frequency for pressure monitoring will be successively reduced during the post-injection phase based on the observed field conditions. If field conditions warrant a revision of the proposed post-injection monitoring frequency, a revised pressure monitoring plan will be submitted to the EPA for review and comment.

### **A-2.5.1.2 Indirect Monitoring of Pressure Front by Surface Displacement**

In addition to direct monitoring, the pressure front will also be tracked by monitoring surface deformation as a result of CO<sub>2</sub> injection using the InSAR approach (Interferometric Synthetic Aperture Radar). This technique will provide an independent means to corroborate the pressure front constructed from direct monitoring of pressures in the Arbuckle injection and monitoring wells. InSAR is a radar technique that measures the phase difference between successive satellite orbits. Tropospheric effects between satellite orbits will be removed using data acquired by the MODIS satellite. Once tropospheric effects are removed, any phase differences between the images will be proportional to small differences in distance between the satellite antenna positions and the ground, which could indicate surface deformation associated with elevated pressures due to carbon dioxide injection at depth.

Archives of InSAR data will be downloaded prior to injection in order to establish a range of baseline surface deformation at the Wellington Field related to seasonal effects (e.g., freeze-thaw cycles and dry vs. wet seasons). During the 9-month injection period and 60 days following injection, InSAR measurements shall be collected approximately every 20 days. Following the injection period, data collection and analysis will continue, but will decrease incrementally to eventually every 12 months until project closure. The InSAR data can provide a time-series of deformation and subsequent relaxation of the ground surface. The InSAR time-series will establish incremental deformation of the land surface due to CO<sub>2</sub> injection and will be compared with plume dimensions obtained from simulation studies and other direct/indirect monitoring data discussed below.

In addition to InSAR data, Continuous GPS (CGPS) data will also be acquired at cemented platforms for purposes of calibration and verification of the vertical component of the surface displacement field using InSAR. The CGPS data will provide 3 components of the surface displacement (i.e., Northing, Easting and vertical) to add tighter constraints to the deformation field detected using InSAR. CGPS data shall be downloaded via a laptop on a monthly basis. All data files (24-hour periods) will be recovered for archiving and analysis to enable detection of surface accelerations related to subsurface deformation.

### **A-2.5.2 Monitoring the Plume Front**

Various direct and indirect MVA tools and techniques shall be used to monitor, verify, and account for injected CO<sub>2</sub> in the Arbuckle saline aquifer. The crosswell tomography, U-tube, 3-D seismic, and continuous active source seismic monitoring (CASSM) technology shall be used to monitor and visualize the movement of the CO<sub>2</sub> plume. The monitored data will also be used to revise the simulation model, update site characterization, and potentially refine the monitoring plan if necessary. Each of the plume monitoring techniques mentioned above, along with the monitoring plan, is discussed below.

### *A-2.5.2.1 Direct Geochemical Monitoring of the Plume Front: U-Tube Sampling*

Understanding the geochemistry of reservoir gases is critical to understanding how carbon is sequestered in geological formations. The U-tube sampler is able to collect continuous samples of reservoir fluids near in-situ temperatures and pressures. This innovative apparatus has greatly enhanced the success of CO<sub>2</sub> injection pilot studies at the Frio Brine Pilot, Dayton, TX, the SECARB Cranfield Test, Cranfield, Mississippi, and the CO<sub>2</sub>CRC Otway Project, Victoria, Australia by significantly improving the quality and quantity of samples that can be collected from deep storage reservoirs during supercritical CO<sub>2</sub> injections. Such sampling is difficult because dissolved gasses and supercritical fluids which exist at high pressures and temperatures in the reservoir quickly exsolve or flash to gas as they are brought to the surface for analysis. The U-tube sampler will be installed in monitoring well KGS #2-28.

The U-tube (Figure A-2.2), which is constructed of stainless steel tubing and fixed within the borehole with tubing strings that reach to the surface, shall be installed in the Arbuckle observation borehole (KGS #2-28). The perforated interval will be isolated using a packer with feed through to accommodate the U-tube sampling system and other permanent instruments. The drive leg of the U-tube is connected to a source of compressed nitrogen and the other attached to a sampling manifold contained in a trailer on site. After first flushing the loop of tubing with N<sub>2</sub> gas, the sample and drive legs are vented and pressure in the U-tube will decrease, allowing subsurface fluids to enter the sampling inlet due the pressure differential between the U-tube (atmospheric) and the reservoir. To recover the sample N<sub>2</sub> gas is again used on the drive leg to increase the pressure in the tubing, closing the check valve and forcing fluid up to a high pressure sampling cylinder. Inside the cylinder, brine, dissolved gases, and supercritical fluids will be collected at near in-situ conditions allowing accurate quantification of the relative concentrations of each component.

The U-tube surface sampling instrumentation will consists of a supply of N<sub>2</sub>, a high pressure gas booster, and a valve panel to facilitate collection of mixed phase and separate phase subsamples. Samples shall be collected on a weekly basis until breakthrough in order to identify the arrival of the CO<sub>2</sub> plume and co-injected tracers (e.g. sulfur hexafluoride). Following breakthrough, samples will be collected initially on an increased sampling frequency and then gradually decreased as geochemical changes slow. Subsamples shall be collected and sent to laboratories for analysis of constituents such as pH, EC, alkalinity, cation and anion chemistry, dissolved gases and isotopic composition as presented in Table A-2.5. If hydrocarbons are present in the subsurface, they shall also be analyzed and may be used in equilibrium thermodynamic models to aid in the estimation of the rate of CO<sub>2</sub> dissolution into the formation brines. Tracer gases

including SF<sub>6</sub> (sulfur hexafluoride) and Kr (krypton) shall be periodically co-injected with the CO<sub>2</sub> to facilitate estimation of the travel time between the injection and monitoring wells/boreholes. Approximately 55 kg of SF<sub>6</sub> and 230 ft<sup>3</sup> of Kr 230 will be injected every eight weeks at KGS #1-28. The resulting data in the Arbuckle observation well (KGS #2-28) will provide key data for calibration and validation purposes.

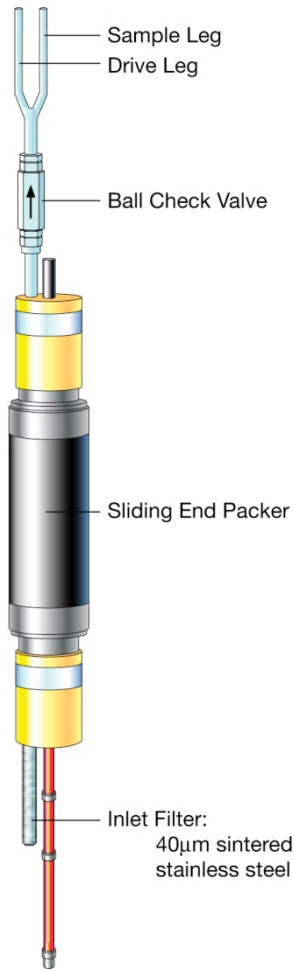

Figure A-2.2 Schematic of the U-tube sampling device.

Table A-2.5 Geochemical analytical suite to be monitored in the Arbuckle monitoring well (KGS #2-28).

Field Parameters	Pre-Injection	During injection	Post-Injection

pH	Once a week for 3 weeks	Every 45 days	Every 6 months
Specific Conductivity	Once a week for 3 weeks	Every 45 days	Every 6 months
Temperature	Once a week for 3 weeks	Every 45 days	Every 6 months
Dissolved Oxygen	Once a week for 3 weeks	Every 45 days	Every 6 months
Gas-Water Ratio	Once a week for 3 weeks	Every 45 days	Every 6 months
Depth to Water	Once a week for 3 weeks	Every 45 days	Every 6 months
TDS/Salinity	Once a week for 3 weeks	Every 45 days	Every 6 months
<b>Indicator Parameters</b>			
Alkalinity	Once a week for 3 weeks	Every 45 days	Every 6 months
Bromide	Once a week for 3 weeks	Every 45 days	Every 6 months
Calcium, Iron, Magnesium, Potassium- um, Dissolved Silica	Once a week for 3 weeks	Every 45 days	Every 6 months
Chloride	Once a week for 3 weeks	Every 45 days	Every 6 months
Sodium	Once a week for 3 weeks	Every 45 days	Every 6 months
Total CO <sub>2</sub>	Once a week for 3 weeks	Every 45 days	Every 6 months
Total Fe	Once a week for 3 weeks	Every 45 days	Every 6 months
Total Fe (II)	Once a week for 3 weeks	Every 45 days	Every 6 months
Total NH <sub>4</sub> <sup>+</sup>	Once a week for 3 weeks	Every 45 days	Every 6 months
Total NO <sub>3</sub> <sup>2-</sup>	Once a week for 3 weeks	Every 45 days	Every 6 months
Total SO <sub>4</sub> <sup>2-</sup>	Once a week for 3 weeks	Every 45 days	Every 6 months
Total PO <sub>4</sub> <sup>3-</sup>	Once a week for 3 weeks	Every 45 days	Every 6 months
Total HCO <sub>3</sub> <sup>-</sup>	Once a week for 3 weeks	Every 45 days	Every 6 months

Total CO <sub>2</sub>	Once a week for 3 weeks	Every 45 days	Every 6 months
		Every 45 days	
<b>Concentration of Organics</b>		Every 45 days	
DOC	Once a week for 3 weeks	Every 45 days	Every 6 months
TOC	Once a week for 3 weeks	Every 45 days	Every 6 months
DIC	Once a week for 3 weeks	Every 45 days	Every 6 months
		Every 45 days	
<b>Stable Isotopes</b>		Every 45 days	
δ <sup>18</sup> O	Once a week for 3 weeks	Every 45 days	Every 6 months
δD	Once a week for 3 weeks	Every 45 days	Every 6 months
δ <sup>13</sup> C for Carbonates in System	Once a week for 3 weeks	Every 45 days	Every 6 months

### **A-2.5.2.2**     *Indirect Geochemical Monitoring of the Plume Front: Seismic Surveys*

Both borehole and surface seismic methods will be used to track the CO<sub>2</sub> plume. Surface seismic data has the advantage of being laterally extensive, but borehole seismic methods (especially crosswell, which will be utilized at Wellington) produce higher resolution images but at less penetration (distance from transmitting and receiving equipment relative to target) than surface seismic methods because seismic waves only pass through weathered surface horizons once (for surface to borehole) or not at all (for cross well), minimizing attenuation and distortion. The higher resolution provided by the borehole seismic may be useful where the carbon dioxide plume is predicted to be thin or complex in shape. The seismic plume tracking techniques and monitoring plans to be employed on the Wellington project are discussed below.

#### **A-2.5.2.2.1**     *High Resolution Seismic Survey*

A 3D seismic survey has already been acquired and processed. This information will provide a baseline to compare with a final 3-D seismic acquisition prior to site closure. The 3D data shall be interpreted and compared with the baseline survey to map the final extent of the CO<sub>2</sub> plume to demonstrate containment in support of site closure.

##### **A-2.5.2.2.2**     **Crosswell Seismic Methods**

Crosswell seismic methods deploy sources and receivers in several different wells, producing a survey that images the plane between the wells. The equipment is generally deployed in wells not more than 1500 feet apart. A seismic source is deployed down one well and seismic sensors are deployed down additional wells. Crosswell surveys using several wells are able to generate three-dimensional crosswell surveys. The crosswell seismic technique measures velocity and attenuation characteristics to model CO<sub>2</sub> saturations and/or pressure changes during CO<sub>2</sub> injection. As illustrated in Figure A-2.3, this technique, in continuous monitoring mode can provide information on how the CO<sub>2</sub> is migrating in the subsurface.

By measuring changes in travel-time and signal amplitude between the wells, tomographic techniques are also used to map velocity and attenuation variations in the section between the wells. These can be used to model CO<sub>2</sub> saturations and/or pressure changes. In addition, cross-hole data can be useful for assessing how effectively the pore space in the storage reservoir is being exploited, which is useful for storage prediction modeling. Because cross-hole seismic utilizes much higher frequencies than surface seismic (up to 1000 Hz or more), it interrogates rock and fluid properties at a much finer scale but with much shorter interrogation distances thereby limiting well separation. Therefore the method provides valuable ancillary information for the quantitative assessment of surface seismic in proximity to appropriately spaced wells. The technology has been successfully utilized to capture the CO<sub>2</sub> plume at the Frio experimental sequestration site in Texas (Figure A-2.4).

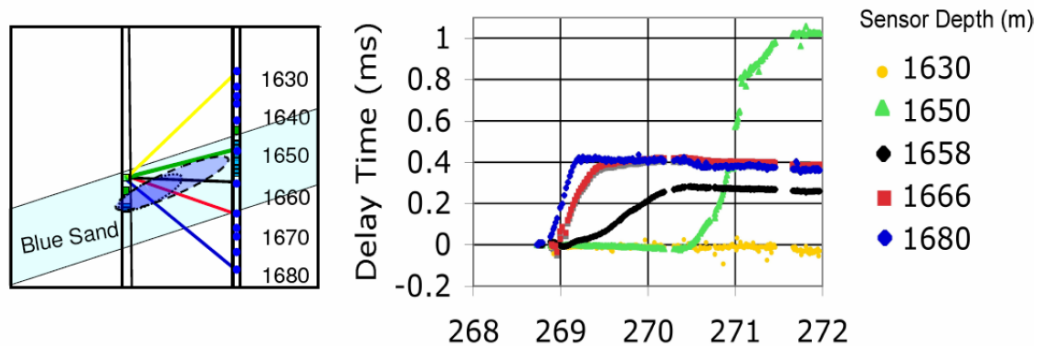

Figure A-2.3 Schematic of continuous active-source seismic monitoring (CASSM) Frio-II experiment with conceptual CO<sub>2</sub> plume after one day (inner short dash) and after two days (outer long dash), with measured delay times at three sensor depths over three and a half days of CO<sub>2</sub> injection (right).

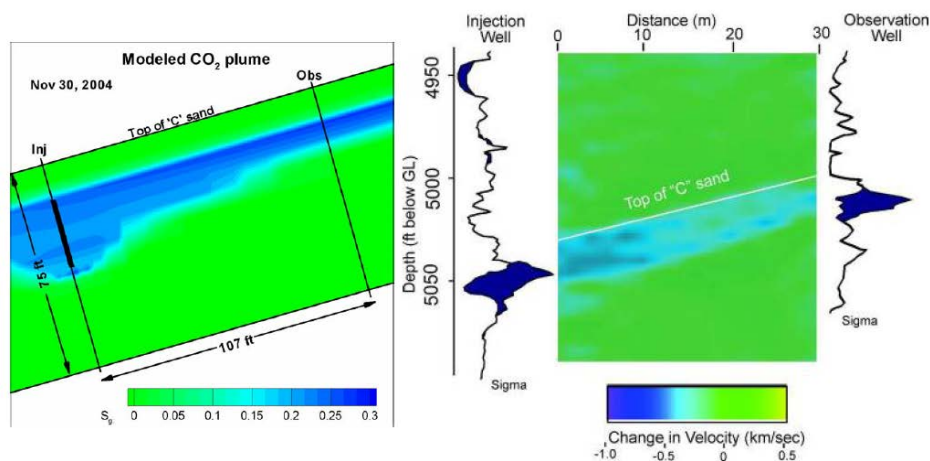

Figure A-2.4 Cross-hole seismic imaging at the Frio experimental site in Texas. Velocity tomography (right) compared with reservoir flow simulation (left); (Images courtesy of Tom Daley (LBNL), Christine Doughty (LBNL) and Susan Hovorka (University of Texas)).

The Arbuckle injection well (KGS #1-28) shall be fitted with the continuous active-source seismic monitoring (CASSM) sources that in combination with the CASSM receivers placed in the Arbuckle observation borehole, KGS #2-28, will enable a real-time monitoring of the CO<sub>2</sub> plume front from the injector well. The Piezotube CASSM source, a hollow cylinder, shall be installed on production tubing in the injection well either above or below the packer (or both). A specially designed source carrier shall be used,

acting as a 'pup' joint of tubing. The installation shall include attaching the cable to power the CASSM source, which shall run to the surface. The CASSM receivers shall be installed on production tubing in the monitoring borehole (KGS #2-28), along with other monitoring instrumentation (Pressure/temperature gauge, U-tube, etc). The CASSM receivers shall be an array of hydrophones or similar sensors, with spatial distribution such that the expected vertical extent of the plume is monitored. The CASSM system will provide monitoring along specific source-sensor ray paths, complimenting the full crosswell tomography survey to be acquired separately.

Pre-injection crosswell tomography survey shall be carried out before the subsurface seismic velocity field is perturbed by the CO<sub>2</sub> injection, and will thus be a 'baseline' for the later surveys and for calculating time lapse changes. The second crosswell tomography survey shall be conducted approximately half way through the injection to estimate the plume location between the Arbuckle injector and observation boreholes.

The CASSM surveys shall be acquired at a temporal resolution on the order of 10-30 minutes, allowing estimation of plume growth in real time, until the instruments are removed for the full crosswell survey. The crosswell survey(s) shall be useful as 'bookends' to the CASSM survey, providing a detailed spatial description of the CO<sub>2</sub> distribution and the seismic wave field. This plan will alleviate the shortcoming of the relatively sparse spatial sampling of the CASSM which leaves uncertainty in some aspects of the interpretation of the seismic waveform and the CO<sub>2</sub> distribution (CASSM focuses on the first arrival only, while crosswell allows understanding of later arriving phases and provides imaging in the entire 2D plane between wells).

## **A-2.6 Reporting of Monitoring Results to EPA**

Results of monitoring activities will be submitted to the EPA as per schedule defined below. Data will be submitted in electronic form directly to EPA's geologic sequestration database where they can then be accessed by the UIC Program Director.

### **Prior-to-Injection Report**

- CO<sub>2</sub> stream analyses
- Descriptive report of initial MIT
- Baseline InSAR data
- Groundwater geochemistry analyses of USDW
- Groundwater geochemistry analyses of Mississippian formation
- Background U-tube geochemistry

### **Semi-annual Report**

- Quarterly carbon dioxide stream characteristics (physical, chemical, other) detailing the list of chemicals analyzed, a description of the sampling methodology and the name of the certified

laboratory performing analysis, sample dates and times, and interpretation of the results with respect to regulatory requirements and past results. Any changes to the physical, chemical, and other relevant characteristics of the carbon dioxide stream from the proposed operating data will also be documented;

- Description of any event(s) that exceeded operating parameters for annular pressure or injection pressure and corresponding action;
- Description of any event(s) which triggered a shut-off device and the corresponding response undertaken;
- Monthly volume and/or mass of carbon dioxide injected over the reporting period;
- Cumulative volume of carbon dioxide injected over the project life;
- Monthly annulus fluid volume added to the injection well;
- If pressure or flow rate exceeded permit limits during the reporting period, an explanation of the event(s), including the cause of the excursion, the length of the excursion, and response to the excursion;
- Identification of data gaps, if any;
- Any necessary changes to the project Testing and Monitoring Plan to continue protection of USDWs;
- Continuous measurement of flow rate and pressure in injection well including:
  - Tabular data of all flow rate measurements
  - Monthly average, maximum, and minimum value for flow rate and volume, injection pressure, and annular pressure
  - Total volume (mass) injected each month
  - Cumulative volume (mass) for the project
  - Demonstration of gauge calibration according to manufacturer specifications
- MIT Results
- Corrosion monitoring information including a description of the techniques used for corrosion monitoring, measurement of mass and thickness loss from corrosion coupons along with a calculated corrosion rate
- Bottom hole pressure results in all monitoring wells including a synthesis and interpretation of the entire historical data set
- InSAR data

- Groundwater geochemistry sampling results and analyses of USDW
- Groundwater geochemistry sampling results and analyses of Mississippian Formation
- U-tube geochemistry results and analyses
- CASSM results
- Seismic results and analyses.

**Results to be reported within 30 days of event occurrence**

- Results of periodic external MITs;
- Any well work performed;
- Any test of the injection well as required by the EPA;
- If conducted, pressure fall-off test results including raw data collected during the fall-off test in a tabular format, measured injection rates and pressures, demonstration of gauge calibration according to manufacturer specifications, diagnostic curves of test results, noting any flow regimes, description of quantitative analysis of pressure-test results, calculated parameter values from analysis, including transmissivity and skin factor.

**Information to be reported within 24 hours of occurrence**

- Any evidence that the carbon dioxide stream or associated pressure front has or may cause endangerment to a USDW;
- Any non-compliance with permit condition(s), or malfunction of the injection system, that may cause fluid migration to a USDW;
- Any triggering of a shut-off system either downhole or on the surface;
- Any failure to maintain mechanical integrity;
- Any release of carbon dioxide to the atmosphere;
- A description of any event that exceeds operating parameters for annulus pressure or injection pressure.

**30 Days Notification**

- Any well workover, or testing in compliance with EPA directives;
- Any well stimulation activities, other than stimulation for formation testing at the injection well;
- Any other injection well testing.

### **A-2.7 Periodic Review of Monitoring Plan**

The testing and monitoring plan will be periodically reviewed to incorporate a) monitoring data, b) operational data, and c) most recent area of review reevaluation. Specifically, a review will be conducted if there is:

- model revision that affect the predicted movement of the plume and pressure fronts (ie, size and shape of AoR,
- evidence of leaching/mobilization of metals or organic constituents in the subsurface which may indicate a need to modify ground water monitoring parameters or analyses,
- operational parameters are outside the expected operating range,
- Area of Review reevaluation,
- well construction, mechanical integrity, and corrosion testing data indicates a need to modify the well testing regime, e.g., by revising MITs or corrosion monitoring activities,
- five years have elapsed since commencement of injection and site closure has not occurred,

The outcome of the review may be an amended testing and monitoring plan which will be submitted to the EPA Director for approval. If an amended plan is not required, then a justification for the same in the form of a report will be submitted to the EPA Director for approval. The amended plans or demonstrations that no amendment is required shall be submitted to the Director for approval as follows:

- (1) Within one year of an area of review reevaluation;
- (2) Following any significant changes to the facility, such as addition of monitoring wells or newly permitted injection wells within the area of review, on a schedule determined by the EPA Director; or

### **A-2.8 Period of Data Retention**

All data collected in support of this Class VI application (including background geologic/hydrogeologic data and analyses, geophysical logs, modeling results, well design and plugging information/reports) as well as all operating information (including all testing/monitoring activities, AoR re-evaluation, corrective action records, post-injection data, and site closure records including data and information used in support of the alternative site care time frame) will be retained for at least 10 years following site closure.

### **A-2.9 Quality Assurance Plan**

All Quality Assurance and Quality Control (QA/QC) measures will be documented in semi-annual MVA reports and all intermediate reports submitted to the EPA that contains field data.

Data obtained from externally contracted laboratories such as for CO<sub>2</sub> stream analyses, water quality testing, temperature/geophysical logs, and corrosion data will be accompanied with the QA/QC protocol and results followed by the respective laboratories.

Quality Assurance/Quality control procedures to be followed for obtaining and handling CO<sub>2</sub> source samples are documented in Section A-2.3.1.4. QA/QC procedures to be followed during acquisition of groundwater quality data above the injection zone is documented in Sections A-2.4.1.3. As discussed in Section A-2.5.1.2, the continuous GPS station will be utilized to calibrate and verify the InSAR satellite data. Instruments installed locally such as pressure transducers and flow meters shall be calibrated as per manufacturer's recommendations and the procedure and results documented in reports submitted to EPA.

## Appendix A-3

### Public Outreach

Public outreach is an integral part of the Wellington project. Being a federally funded pilot project, KGS follows all guidelines in the DOE/NETL publication, *Best Practices for Public Outreach and Education for Carbon Storage Projects*. The goal of the outreach program is to establish communication between KGS and the host community in order to provide a means to solicit community input, build trust, and ensure the community that the project will be executed safely and responsibly. Specific goals include:

- Educate citizens how CO<sub>2</sub> storage works, how it can contribute to global climate change mitigation, and that the project is part of a national strategy to reduce greenhouse gas emissions,
- Assure the community that KGS and the project operator, Berexco, have the appropriate expertise to safely execute the project,
- Allow the public to express their views,
- Proactively and constructively address community concerns.

Key constituents include public officials, legislators, environmental regulators, business interests, landowners and neighbors, civic groups, environmental groups, educators, and the media. The venues and means for communication/outreach include:

- Meetings or focus groups with stakeholders and the public,
- Community events and open houses,
- Interviews with community leaders,
- Conducting site visits and tours,
- Reporting of monitoring data to the regulatory agency,
- Interactions with the media.

The Principal Investigator of the project, Lynn Watney, has already conducted several meetings with citizens and legislators to inform them of the proposed project. The key messages that are being communicated include:

- There is a well understood approach to site selection and characterization to ensure that geologic conditions are suitable for long term storage without leaks,
- Why Wellington, KS is a safe place to store CO<sub>2</sub> ,
- Standard practices will be followed to guarantee safety and to ensure that CO<sub>2</sub> storage will not cause harm to health or jeopardize the environment,
- How a computer simulation of subsurface CO<sub>2</sub> location is developed, validated, and calibrated, and what the results indicate,
- Role of EPA in overseeing/regulating CO<sub>2</sub> storage,
- Potential costs and benefits to the community from CO<sub>2</sub> storage,
- Natural geologic CO<sub>2</sub> storage has occurred for millions of years,
- Engineered geologic storage of CO<sub>2</sub> has been safely practiced for 40 years. Over three billion cubic feet (176 thousand metric tons) of natural CO<sub>2</sub> is injected daily into west Texas oil fields to recover additional oil. The limited supply of natural CO<sub>2</sub> hinders expansion of this technology in Kansas, and the use of anthropogenic and largely ignored CO<sub>2</sub> is a natural next step,
- Injection and reservoir monitoring are mature technologies. The experience in the oil and gas exploration and development industry is being used to ensure sequestration success. Injection and reservoir management in Kansas oil fields has been ongoing for decades since oil production peaked in 1956,
- There are similarities between the major expansion of oil and natural gas systems after World War II with respect to pipeline and natural gas storage, and the expected deployment of CO<sub>2</sub> storage projects,

In order to facilitate the outreach efforts, KGS has developed a dedicated web site for the project ([http://www.kgs.ku.edu/PRS/Ozark/small\\_scale.html](http://www.kgs.ku.edu/PRS/Ozark/small_scale.html)).

## **Appendix A-4**

### **Class VI Injection Well Permit for KGS #1-28**

KGS is in the final stages of completing the EPA Class VI injection well permit application for submittal to the EPA Region 7 UIC Director. The permit will be filed by the site operator, Berexco, Inc. of Wichita, KS. KGS is in the process of incorporating final comments by Berexco which were received on January 24<sup>th</sup>, 2014. The permit application documents are expected to be filed with EPA by March 1<sup>st</sup> 2014. An executive summary of the permit application is provided below:

#### **Executive Summary**

A small scale pilot carbon capture and storage (CCS) project is proposed by Berexco, Inc and Kansas Geological Survey at the Wellington oilfield approximately four miles northwest of the City of Wellington in Sumner County, Kansas (Figure ES-1). The project is part of a US Department of Energy (DOE) funded pilot scale study to demonstrate the ability of the 4,000 feet deep Cambrian-Ordovician age Arbuckle saline aquifer to accept and retain carbon dioxide (CO<sub>2</sub>) for permanent geologic sequestration. Approximately 40,000 tons of anthropogenic CO<sub>2</sub> is to be injected in the Arbuckle aquifer over a period of 9 months. The details of the project and EPA Underground Injection Control (UIC) Class VI construction, operations, monitoring, well plugging, Area of Review (AoR), post-injection site care and site closure, emergency remedial/response, and financial responsibility plans are summarized below.

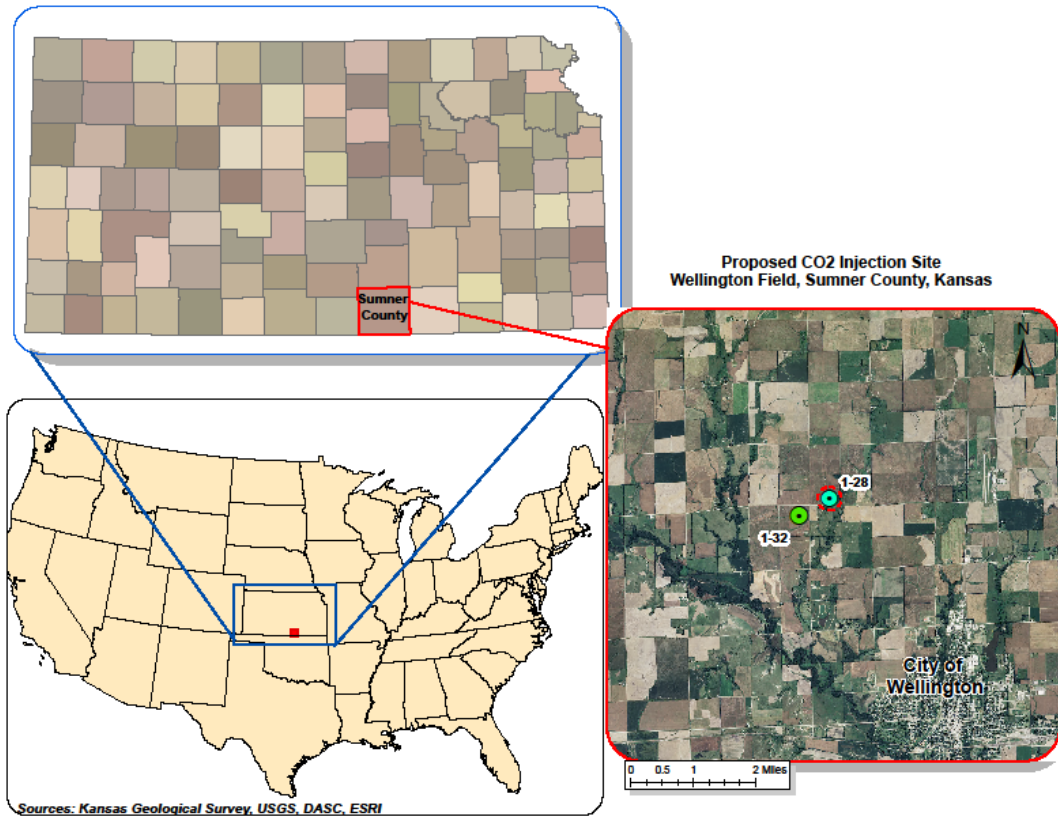

Figure ES-1 Location of small-scale CO<sub>2</sub> storage site at Wellington, Kansas

### Site Setting

The Wellington sequestration site is located in a rural area where land is used primarily for (non-irrigated) crop cultivation (Figure ES-2). CO<sub>2</sub> injection is to occur at the recently completed well (KGS #1-28) which was constructed per EPA UIC Class VI specifications. There are no potable water wells in the vicinity of the injection well. The EPA AoR based on the maximum extent of plume migration is only 1,750 feet from the well as shown in Figure ES-2.

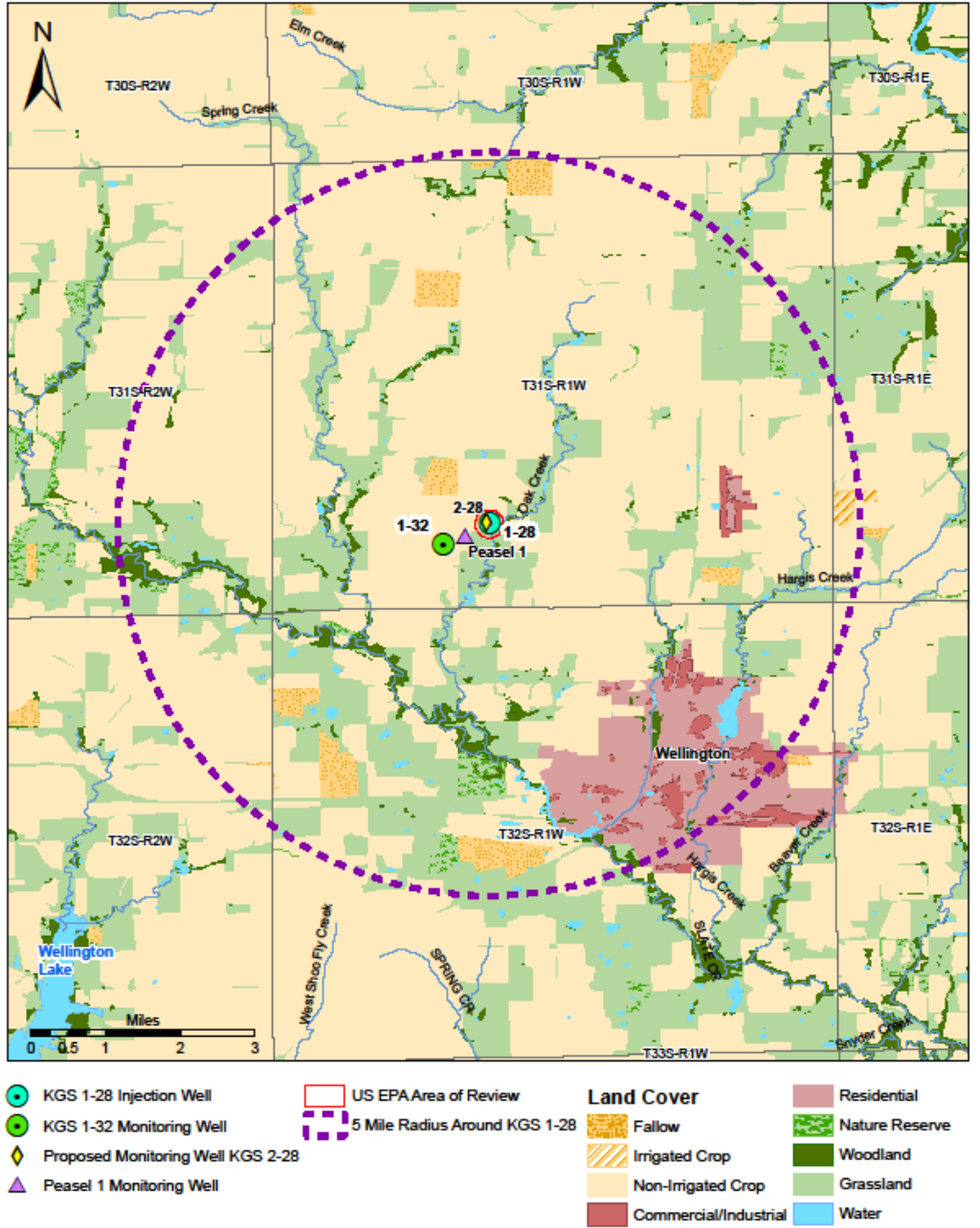

Figure ES-2 Land use in the vicinity of the Wellington small-scale CO<sub>2</sub> storage site

## Geology

### **Arbuckle Group (Injection Zone)**

The geologic column at the injection well site is presented in Figure ES-3. The injection is to occur in the 1,000 ft thick regionally extensive Arbuckle Group of Cambrian-Ordovician period located approximately 4,160 feet below ground at the Wellington site. The injection is to occur near the base of the Arbuckle Group, which has relatively higher permeability as compared to the rest of the formation.

### **Simpson Group/Chattanooga Shale/Pierson Formation (Upper Confining Zone)**

The Ordovician and Devonian shales within the Simpson Group and Chattanooga Shale, along with the argillaceous siltstone in the Pierson Formation of Mississippian subsystem, have the characteristics of caprock and will therefore function as the top confining zone and effectively prevent upward migration of CO<sub>2</sub>. The 240 feet thick confining zone has no known communicative fractures between the Arbuckle injection zone and Mississippian oil and gas reservoir overlying the confining zone. There are several thick layers of shale above the upper confining zone as well as shown in Figure ES-3, which can potentially provide additional impedance to flow, but which are not relied in this application to demonstrate confinement potential.

### **Precambrian Granitic Basement (Lower Confining Zone)**

Precambrian-age basement granites underlie the Arbuckle Group throughout Kansas, and are expected to provide hydraulic confinement at the base of the injection zone.

### **Upper Wellington Formation (USDW)**

The lowermost and only Underground Sources of Drinking Water (USDW) extends from land surface to 250 feet below ground and comprises of Permian shales in the Upper Wellington Formation as shown in Figure ES-3. Below the Upper Wellington are the Hutchinson Salt Beds which overlies bedrock shales in the Lower Wellington Formation. The USDW (Upper Wellington formation) lies approximately 4,500 feet above the top of the injection zone in the lower Arbuckle aquifer. There are no groundwater withdrawals in the vicinity of the Wellington CO<sub>2</sub> storage site.

## Estimated Sequestration Capacity of Arbuckle Group

The total amount of CO<sub>2</sub> that could be stored in the Arbuckle Group within Kansas is estimated by the US DOE to be as high 89.5 billion metric tons, the equivalent of several years of annual CO<sub>2</sub> emissions (approximately 6 billion metric ton/year) for the entire United States. Approximately 300,000-360,000 metric tons of CO<sub>2</sub> per square mile can be stored in the Arbuckle aquifer at the Wellington site as shown in Figure ES-4. Only 40,000 metric tons of CO<sub>2</sub> will be injected into the Arbuckle during a period of 9 months, which as per DOE estimates should be stored in an area of 1/10<sup>th</sup> of a square mile.

# Injection Well Schematic

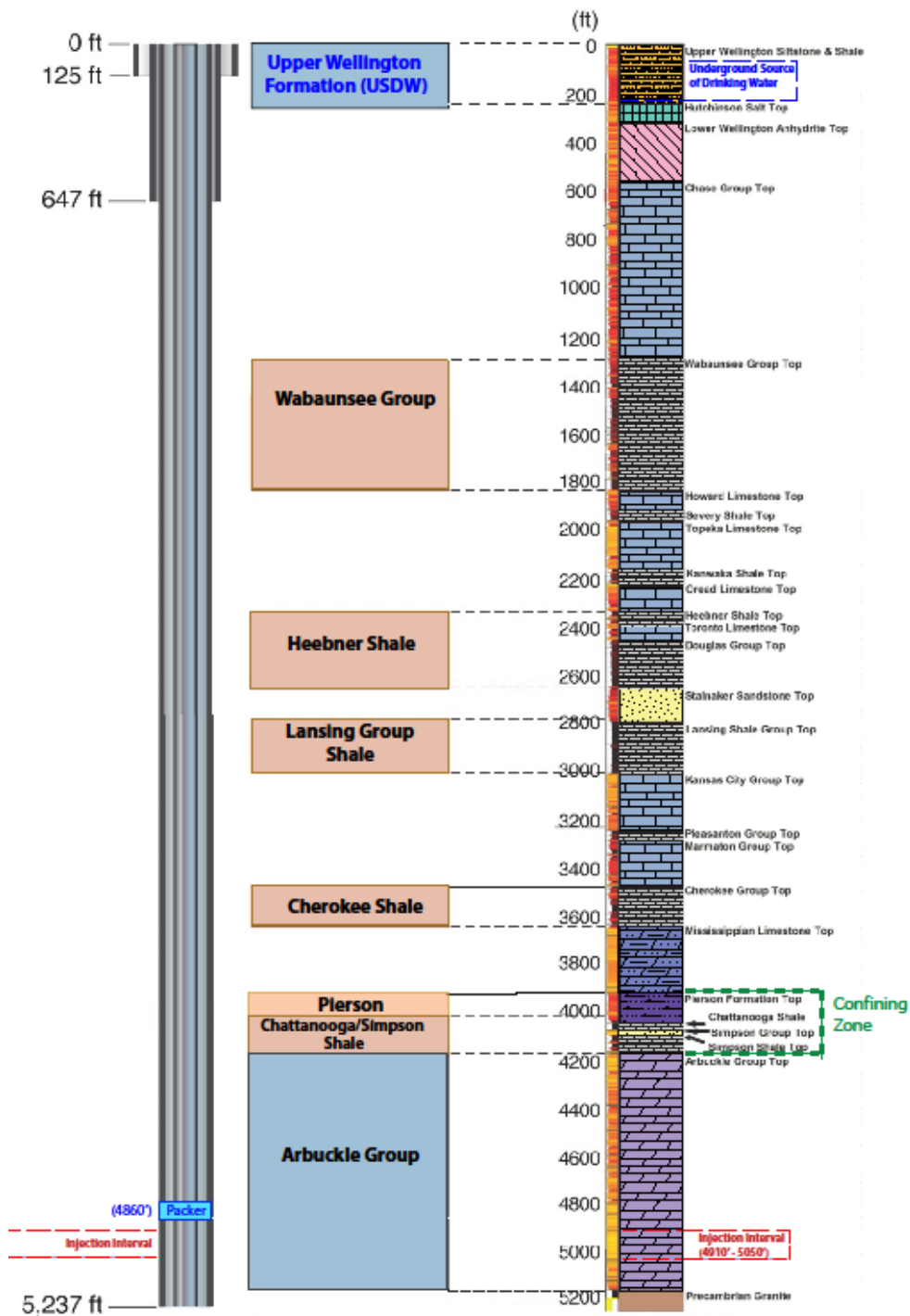

Figure ES-3 Schematic of injection well showing geologic formations at Wellington sequestration site.

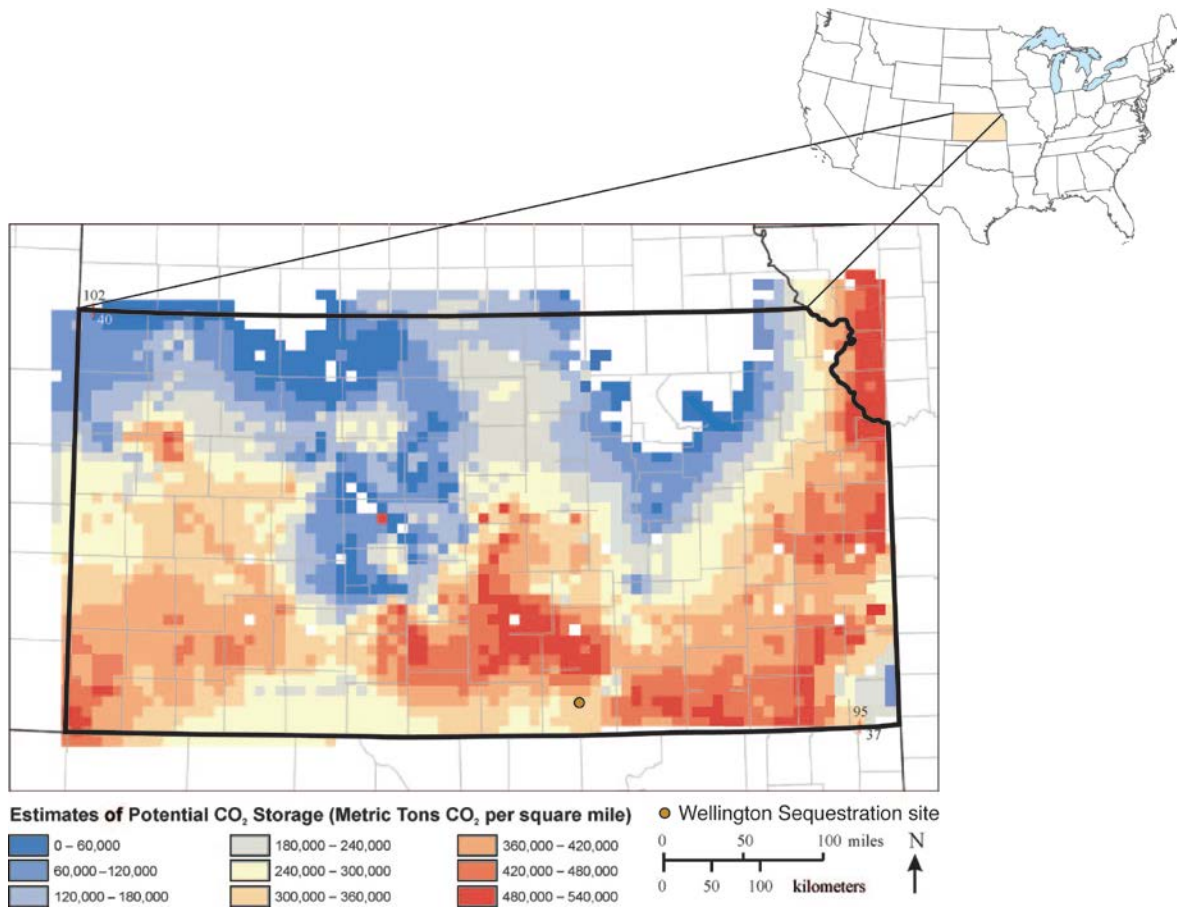

Figure ES-4 Map showing the estimated sequestration potential in the Arbuckle saline aquifer in metric tons CO<sub>2</sub> per square mile.

## Modeling

During construction of the injection well (KGS #1-28) and the geologic characterization well (KGS #1-32) shown in Figure ES-1, an extensive suite of geophysical logs were obtained to understand the geology and hydrogeology, and derive petrophysical properties. These included the Array Compensated True Resistivity, Temperature, Compensated Spectral Natural Gamma Ray, Microlog, Spectral Density Dual Spaced Neutron, Annular Hole Volume Plot, Extended Range Micro Imager Correlation Plot, Radial Cement Bond, Composite Plot, and Magnetic Resonance Imaging logs. The data was used to develop a reservoir simulation model of the Arbuckle Group. An extensive set of computer simulations were conducted using the base case model and nine alternative models in order to account for parametric uncertainty and to bracket the impacts of CO<sub>2</sub> injection on subsurface fluid pressures and extent of CO<sub>2</sub> plume migration. The underlying motivation was to determine if the injected CO<sub>2</sub> could negatively impact the USDW, or potentially escape into the

atmosphere through existing wells or faults/fractures that may either be present, reactivated, or created by the injected fluid.

Simulation results indicate that the maximum pressure induced in the Arbuckle aquifer are insufficient to cause vertical migration of the brines into the USDW due to under-pressurization of the Arbuckle aquifer. The (pre-injection) heads in the Arbuckle injection zone are approximately 600 feet lower than heads in the USDW. Simulation results also indicate that the pressures induced due to injection will dissipate within three months of cessation of injection. Also, the maximum pressures induced at the top of the Arbuckle are insufficient to cause Arbuckle fluids to migrate upward due to the high entry pressure of the confining zone.

Simulations results indicate that the CO<sub>2</sub> will largely remain confined in the lower Arbuckle injection zone and not migrate even into the mid-Arbuckle (Figure ES-5a). The induced pore pressures drop to levels below that necessary to cause vertical migration of the brine at a distance of a few tens of feet from the injection well. Laterally, the maximum extent of the plume (with CO<sub>2</sub> saturation of less than 1%) is expected to be approximately 1,750 feet from the injection well as shown in Figure ES-5b, and the plume growth is expected to cease in less than a year of cessation of injection. Therefore, a post-injection monitoring period of one year is proposed as indicated below.

Global Mole Fraction(CO<sub>2</sub>) 2114-01-01 J layer: 66

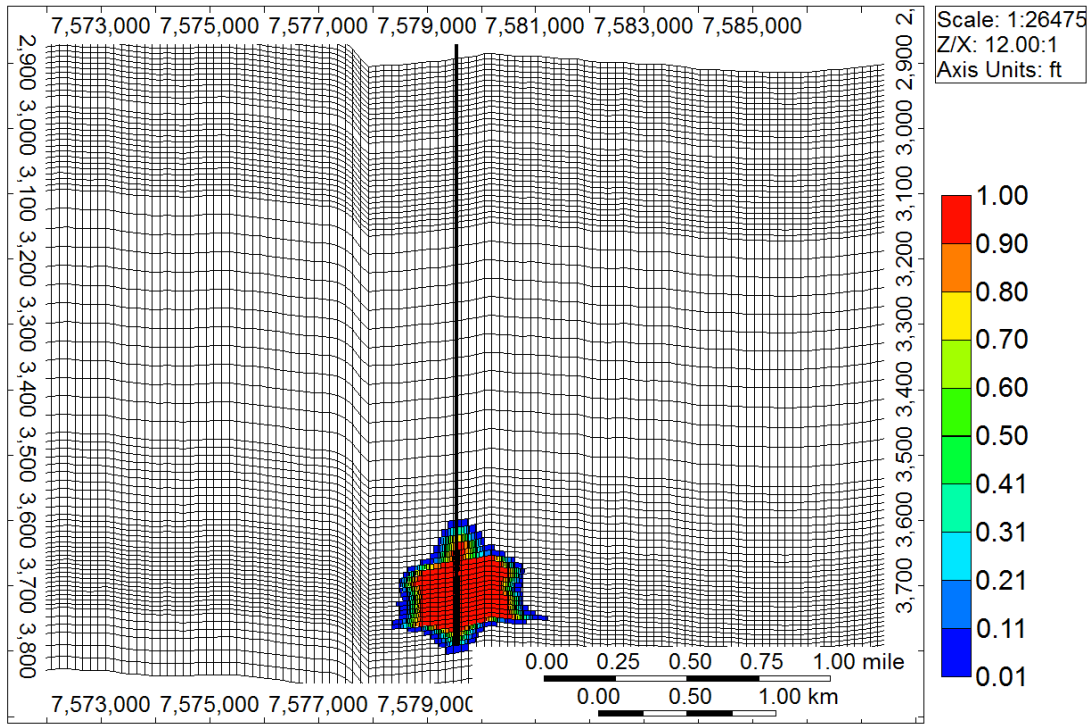

Figure ES-5a Vertical extent of CO<sub>2</sub> plume migration at the end of 100 years following injection

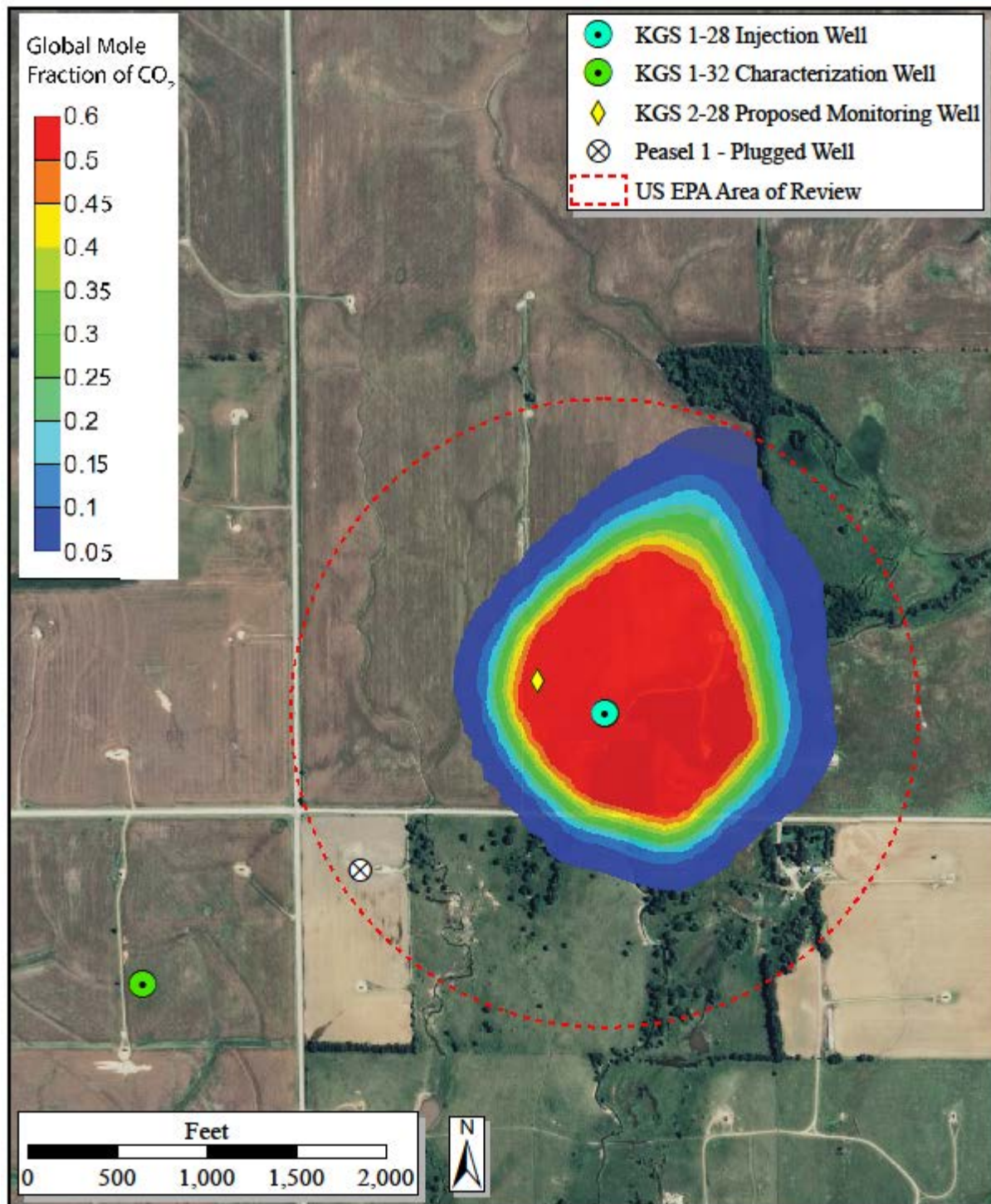

Figure ES-5b Maximum lateral extent of CO<sub>2</sub> plume migration.

## **AoR and Corrective Action**

The EPA AoR derived for the Wellington project is based on EPA's *Maximum Extent of the Separate-phase Plume or Pressure-front (MESPOP)* methodology. It was determined that the pressures to be induced due to injection of CO<sub>2</sub> at Wellington are insufficient to cause brines from the Arbuckle Group to migrate vertically into the USDW through any natural or artificial penetration. Therefore, the AoR is based on the maximum extent of plume migration, which as shown in Figure ES-5b extends approximately 1,750 feet from the injection well. There are no existing or abandoned wells (other than the proposed injection well) either in the Arbuckle Group or the overlying confining zone within the AoR. Therefore, no well corrective action is required.

Following commencement of injection, if significant deviations in the projected formation pressures and plume migration patterns are observed, then the reservoir model may be recalibrated which will trigger an automatic reevaluation of the AoR and Corrective Action Plan. This iterative process may continue until field based observations and model projections are in agreement.

## **CO<sub>2</sub> Compatibility in Injection Zone and Well**

Geochemical analyses suggests that the injection of anthropogenic CO<sub>2</sub> should not cause any compatibility problems with formation waters and minerals in the Arbuckle Group, which could result in reduced pore space, excessive formation/well pressures, or any hindrance to injection operations or geologic storage.

The tubing, casing, packer, and cement of the injection well are also designed for CO<sub>2</sub> injection operations (Figure ES-6). The chemical composition of the injectate should cause no adverse reactions or degradation of the well components for the short nine month duration of injection. The low water content of the injected CO<sub>2</sub> and the low temperatures will result in only a mildly corrosive environment. Quarterly monitoring for corrosion using coupons however is to be conducted in order to provide early warning of a deteriorating environment.

**Wellbore Diagram**

LEASE Wellington KGS #1-28 API 15-191- 22590  
NE SW SE SW Sec 28 31s - 1w Sumner COUNTY KANSAS

Perforate Arbuckle for CO2 Injection 4910' to 5050'

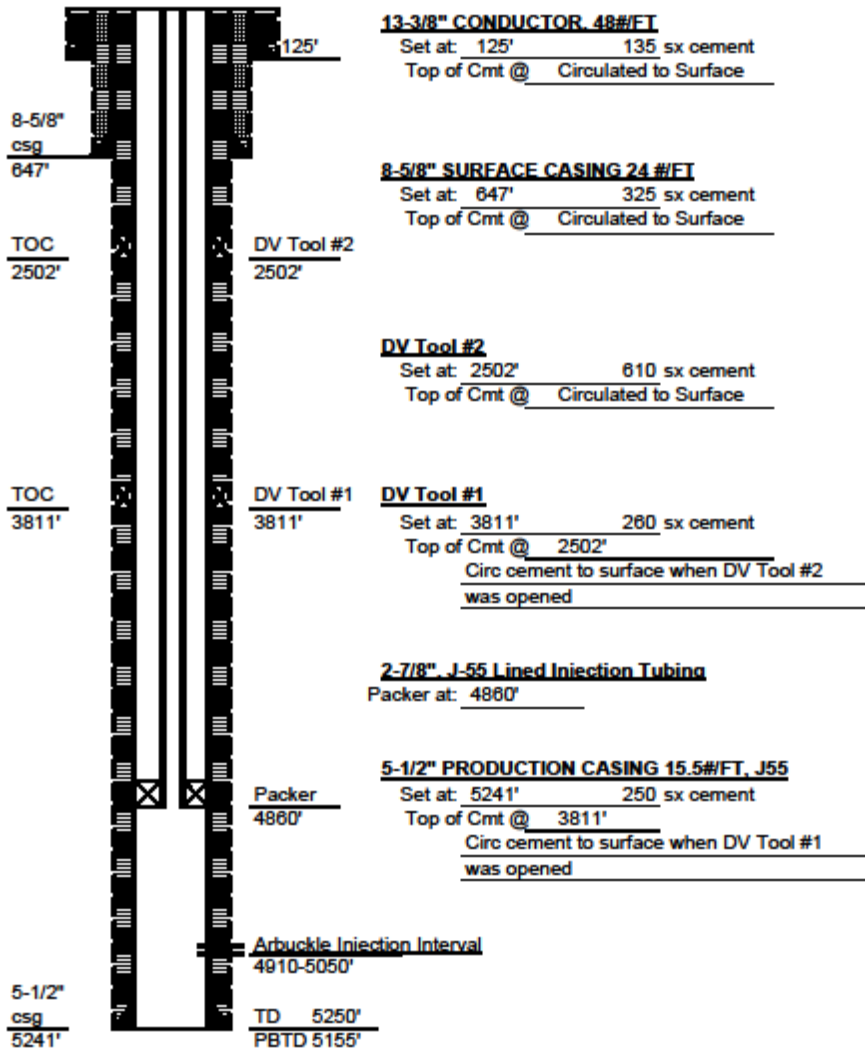

Wellington KGS #1-28 Wellbore Diagram.xls  
 08 Date Printed: 12/02/11

Figure ES-6 Well construction details of injection well KGS #1-28.

## Testing and Monitoring Plan

A total of twenty three monitoring wells will be used for tracking the CO<sub>2</sub> plume and pressure front. The locations of these monitoring wells and the formations they will monitor are shown in Figure ES-7. Three monitoring wells are located in the Arbuckle aquifer. Five existing Mississippian wells will be used to check if CO<sub>2</sub> has escaped upward from the primary confining zone (base of Simpson Group to top of Pierson Formation) at the site. Twelve shallow wells in the Upper Wellington Formation (USDW), and two in the Chase Group under the Wellington Formation, will be monitored to protect potable water supply in the area. Both direct and indirect measurement methods will be used to monitor the movement of the pressure and plume fronts, identify potential risks to USDWs, and to verify predictions of plume movement.

### Injection Well Monitoring

The surface and bottomhole pressures and temperatures will be monitored continuously at the injection well. The chemical composition of the injectate will be tested quarterly in order to ensure that it does not qualify as hazardous waste with regard to corrosivity or toxicity. Due to the short nine month period of injection, corrosion is not expected to occur in the Wellington injection or observation wells. However, corrosion coupons will be used for monitoring loss of material in the Arbuckle injection and monitoring wells on a quarterly basis.

Internal and external Mechanical Integrity Tests (MITs) will be conducted prior to, during, and following injection. Temperature logs will be used to demonstrate external MIT. Prior to commencing injection, an Annulus Pressure Test will also be conducted at the injection well to demonstrate internal mechanical integrity. The test will provide information necessary to determine whether there is a failure of the casing-cement bond, injection tubing, and packers.

A pre-injection pressure fall-off test will be conducted in order to estimate formation properties in the vicinity of the injection well. This information will serve as a baseline in the event of any changes in the near-wellbore environment that may impact injectivity and result in pressure increases.

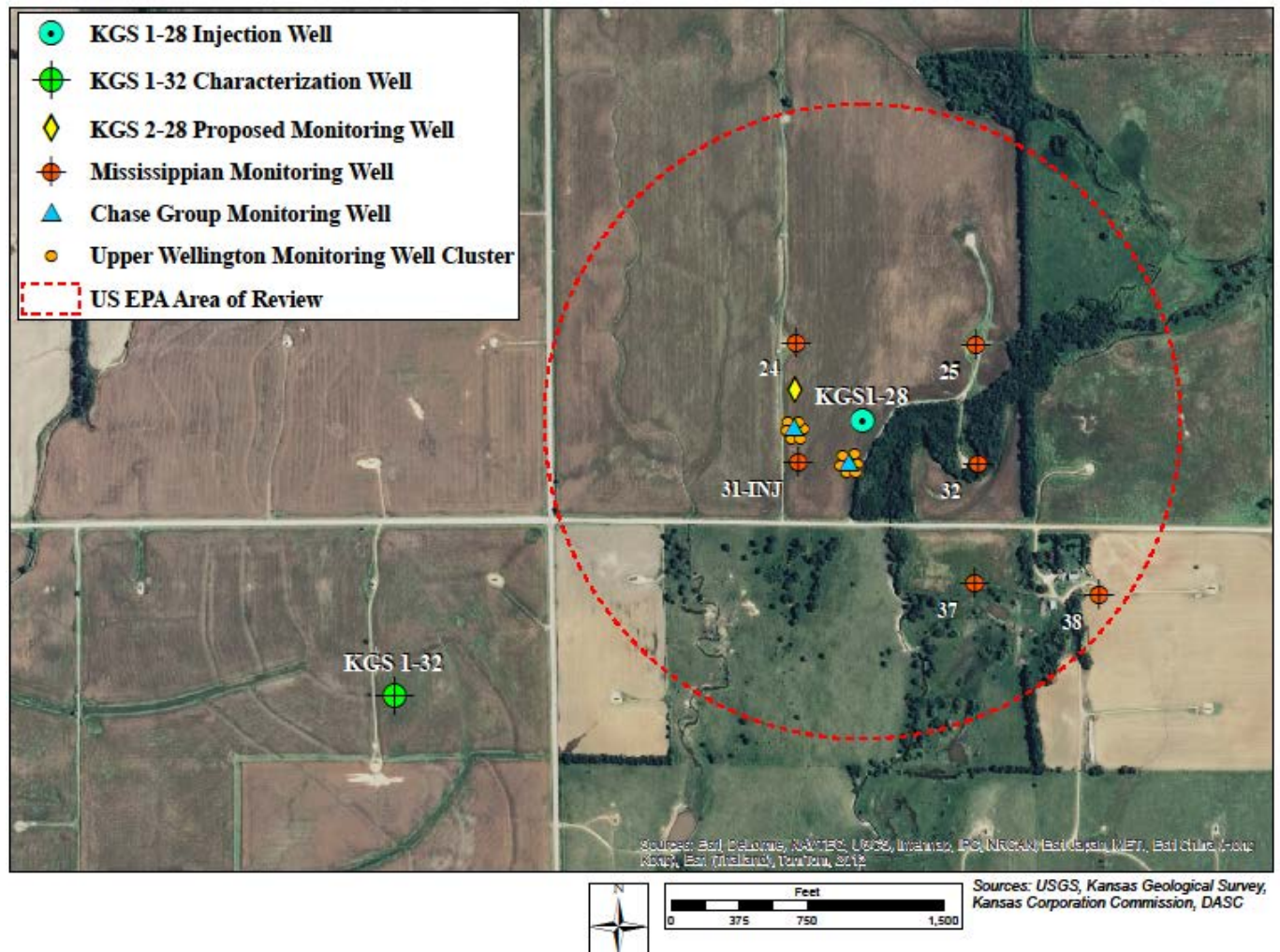

Figure ES-7 Location of monitoring wells in the Arbuckle, Mississippian, and Wellington formations

### Pressure Front Monitoring

Pressure transducers will be installed in the Arbuckle injection and monitoring wells (KGS #1-28, KGS #2-28, KGS #1-32, and Peasel-1). The acquired pressure data will be compared with model based prediction of the pressure front, and if necessary, the simulation model will be recalibrated to conform to field data. In addition to direct monitoring, the pressure

front will also be tracked areally by monitoring surface deformation using InSAR (Interferometric Synthetic Aperture Radar) remote sensing technique.

### **Monitoring the Plume Front**

Various direct and indirect MVA tools and techniques shall be used to monitor the plume front. The crosswell tomography, U-tube, and continuous active source seismic monitoring (CASSM) technology shall be used to monitor and visualize the movement of the CO<sub>2</sub> plume. Sampling and analysis of water and casing head gas from existing Mississippian wells/boreholes around the Arbuckle injector shall be used to determine if injected CO<sub>2</sub> has breached the confining zone and escaped into the overlying Mississippian Reservoir. Shallow groundwater sampling and analysis will help confirm if any injected CO<sub>2</sub> has reached the USDW. The newly acquired data will be compared with the existing baseline seismic data in order to track the plume movement. The monitored data will also be used to revise the simulation model, update site characterization, and potentially revise the monitoring plan if deemed necessary.

A 3-D seismic survey will also be undertaken prior to closure, in order to validate the absence of CO<sub>2</sub> outside the containment strata and confirm that future leakage risks are minimal to non-existent.

### **Geomechanical Failure and Seismic Risk**

Simulation results indicate that the pressures induced due to CO<sub>2</sub> injection at KGS 1-28 are insufficient to initiate new fracture, propagate existing fractures, or cause slippage along any existing fault planes. There are no documented faults in the vicinity of the injection well, with the closest fault approximately 12.5 miles southeast of the site where negligible pressures will be induced due to injection. The Wellington storage site (and all of Kansas) is in a low seismic hazard area as defined by the United States Geological Survey. Historical record indicates that most earthquakes in Kansas are small with the largest measured at 4.0 on the Richter scale, which is not of sufficient strength to cause any infrastructure damage.

### **CO<sub>2</sub> Trapping Potential of the Mississippian Oil Field**

The Mississippian oil reservoir lies immediately above the primary upper confining zone. It is a highly under-pressurized system which is likely a consequence of oil and gas production that has occurred in this

formation since the early 1900s. Due to this under-pressurization, any CO<sub>2</sub> that may escape from the primary confining zone is likely to be trapped in the Mississippian formation. This under-pressurization could not have existed in the absence of a competent low permeability confining zone between the Arbuckle and the Mississippian systems, which essentially provides a hydraulic seal between the two formations.

### **Injection Well Construction**

The 5,241 ft deep injection well (KGS 1-28) penetrates the top of the pre-Cambrian basement rock at a depth of approximately 5,160 feet. The well will be perforated between 4910 – 5050 feet for injection into the highly permeable lower Arbuckle zone as shown in figures ES-3 and ES-6. The injection well was constructed in accordance with UIC Class VI construction guidelines using CO<sub>2</sub> resistant cement and corrosion resistant material in the production casing and injection tubing. The tubing and the casing are designed to withstand axial, burst, and collapse stresses. Cement bond and variable density logs were acquired after setting and cementing the surface casing and long-string casing. These logs do not indicate any loss of mechanical integrity.

### **Injection Well Plugging Plan**

The injection well and potentially the Arbuckle monitoring well (KGS #2-28) will be plugged as per UIC Class VI specifications to the top of the Pierson Formation, which corresponds to the top of the confining zone. Both wells may be used in the future for CO<sub>2</sub> Enhanced Oil Recovery (EOR) injection or other oilfield operations in the locally producing Mississippian formation, so plugging will only occur to the base of the intended oil recovery zone (top of Pierson Formation). The Arbuckle monitoring well KGS #2-28 will be plugged as a Class VI well in the event that the CO<sub>2</sub> plume reaches this well, or is expected to reach this well at any time in the future.

### **Surface Facilities and Operations**

The planned volume of CO<sub>2</sub> injection is 150 metric tons per day. The CO<sub>2</sub> will be transported to the site in trucks in liquid state at a pressure of approximately 250 pounds per square inch (psi) and temperature of -10° F. The surface facilities at the Wellington injection site will consist of a storage tank, a pump, a programmable logic controller (PLC), and wellhead. The bottom hole and wellhead pressures and temperatures will be continuously monitored along with the flow rate and the data fed continuously to the

PLC. The PLC will manipulate the control valve in order to not exceed the maximum specified flow rate and to ensure that the bottom hole pressure in the injection well does not exceed the maximum allowable pressure, which corresponds to 90% of the fracture pressure. The PLC will be programmed to initiate shutdown if the operating ranges are exceeded.

### **Post Injection Site Care and Site Closure Plan (PISC)**

Due to the expected stabilization of the pressure and plume fronts in less than a year following cessation of injection, it is proposed that site be closed one year after cessation of injection. Upon cessation of injection, the most recently acquired field data will be used to refine the reservoir model if necessary, and update simulation results and the projected pressure front and plume movement. The revised projections will be used to determine whether the monitoring, AoR, and PISC plans are adequate to ensure accurate tracking of the plume/pressure front and support closure of the site. If necessary, this process of data acquisition and model refinement/projections may continue in order to determine whether or not the injected CO<sub>2</sub> could migrate out of the storage formation into the USDW. Once a determination of no negative impacts to the USDW is made, an application for site closure will be filed with the EPA Director.

### **Emergency Remedial Response Plan**

An Emergency Remedial Response Plan has been prepared and will be implemented if Berexco obtains evidence that the injected CO<sub>2</sub> stream and/or associated pressure front may endanger the USDW. Specific plans are outlined for a variety of emergency conditions related to testing, monitoring, and mechanical failure. The plans involve immediate cessation of injection, identification and characterization of the failure, notification of the EPA UIC Program Director within 24 hours, and implementation of the appropriate response and remedial action. In addition to executing an automatic shutdown, the PLC will also notify Berexco of a shutdown over cellular network.

### **Financial Responsibility Plan**

Due to its extensive experience in subsurface oil and gas operations and strong financial position, Berexco, is opting for the self-insurance option to demonstrate Financial Responsibility to carry out CO<sub>2</sub> storage activities related to performing well corrective action, injection well plugging, post-injection site care, site closure and implementing an emergency/remedial plan . Berexco meets or exceeds all minimum financial

coverage criteria to demonstrate financial strength and ability to complete sequestration activities. It should also be noted that the Wellington project is part of a cooperative agreement with the US DOE. The US DOE has obligated approximately 11 million dollars for this project. Therefore, financial risks to Berexco are minimal.

### **Conclusions and Risks to USDW**

Detailed AoR, Construction and Operations, Testing and Monitoring, Injection Well Plugging, Post-Injection Site Care and Site Closure, Emergency and Remedial Response, and Financial Responsibility plans have been prepared and documented in this application to fulfill all EPA requirements for developing and operating a Class VI CO<sub>2</sub> geologic sequestration project.

The modeling based projections for the small-scale pilot project indicate that the subsurface pressures induced due to CO<sub>2</sub> injection will be insufficient to cause vertical migration of brines from the injection zone into the USDW. Additionally, the injected CO<sub>2</sub> is expected to be contained within the injection zone in the lower portions of the Arbuckle, and the plume to stabilize within one year of cessation of injection. Therefore, risk of contamination of the USDW from injection operations at Wellington is minimal.

## Appendix A-5

### System Design and Operations

#### A-5.1 Introduction

This section documents all steps undertaken to ensure that the injection well (KGS #1-28) and the proposed monitoring well (KGS #2-28) are constructed and completed to:

- 1) Prevent the movement of fluid into or between Underground Sources of Drinking Water (USDWs),
- 2) Permit the use of appropriate testing devices and workover tools,
- 3) Permit continuous monitoring of the annulus space between the injection tubing and long string casing.

Additional operational and construction information provided in this section include:

- (1) Proposed operating data for the CO<sub>2</sub> site,
- (2) Proposed pre-operational formation testing program to obtain an understanding of physical characteristics of the injection zone,
- (3) Proposed stimulation program, a description of stimulation fluids to be used and a determination that stimulation will not interfere with containment,
- (4) Schematics of the subsurface construction details of the well.

#### A-5.2 Background

Well KGS #1-28 is located in central Sumner County and will be used to inject CO<sub>2</sub> into the Arbuckle Group. The well design and construction details are provided in Figure A-5.1. The 5,241 foot deep well penetrated the top of the pre-Cambrian basement rock at a depth of approximately 5,165 feet. The well has subsequently been plugged to a depth of 5,155 feet. As shown in Figure A-5.1, the well will be

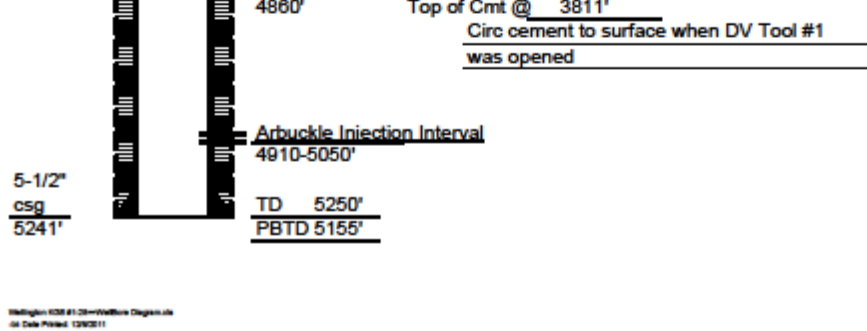

### A-5.3 Operational Information Relevant to Well Construction

Surface facilities at the site will consist of a CO<sub>2</sub> storage tank, an injection skid, wellhead, necessary piping and instrumentation, and a programmable logic controller (PLC) or programmable chart recorder for automated injection operation and monitoring. Information pertaining to the surface equipment and the operational plans are also specified below. Approximately 150-300 tons of CO<sub>2</sub> will be transported to the well site on a daily basis. This will likely take place by delivery in one to ten trucks operating daily between the Wellington sequestration site and the CO<sub>2</sub> source selected for project supply. The controller will be programmed to automatically control the injection flow rate based on the operational parameters discussed below, intended pilot scale research activities, and the operational limits specified in Table A-5.1. Critical issues regarding typical operating conditions and limits are presented in the following subsections.

#### A-5.3.1 Temperatures

The temperature of the CO<sub>2</sub> during transportation and in the site storage tank is expected to be between approximately -10° and 10° F at delivery. This temperature may increase depending on ambient conditions and the duration of CO<sub>2</sub> storage in the tanks. As the CO<sub>2</sub> is stored and travels through surface equipment and approximately 4,900 ft down the injection tubing, the temperature will rise depending on ambient conditions, the injection rate, and the temperature in the formations surrounding the well. Near the wellbore, formation temperatures will gradually change over time as the cool CO<sub>2</sub> is injected in the well. The bottom hole temperatures cannot be predicted with certainty, but for purposes of selecting appropriate monitoring gauges and estimating CO<sub>2</sub> density with depth, a temperature range of 10° to 70° F at the bottom hole, and -10° F to +30° F at the surface is estimated (Table A-5.1).

**Wellbore Diagram**

LEASE Wellington KGS #1-28 API 15-191- 22590  
 NE SW SE SW Sec 28 31s - 1w Sumner COUNTY KANSAS  
 Perforate Arbuckle for CO2 Injection 4910' to 5050'

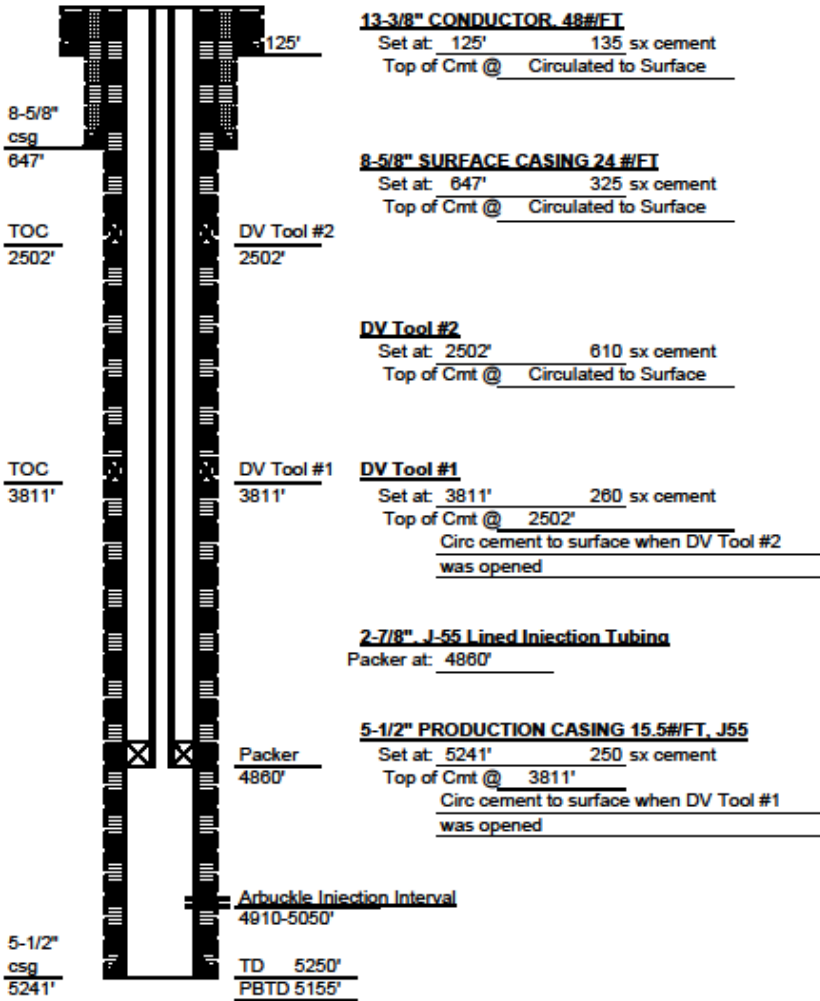

Wellington KGS #1-28-Wellbore Diagram.dwg  
 Job Date Plotted: 12/02/11

Figure A-5.1—Well design and construction details KGS #1-28

Table A-5.1—Probable Operational Conditions at KGS 1-28.

Parameter	Lower Limit	Average	Upper Limit
Injection Rate	0	150 tons/day	300 tons/day (Intermittent or continuous)
Surface Temperature	-10°F	+0°F - +20°F	+30°F
Bottom hole Temperature	+10°F	+20° F - +40°F	+70° F
Surface Pressure	0 psi	100 - 800 psi	1,500 psi
Bottom hole Pressure @ 5,050 ft (bottom of perforation)	2,200 psi	2,600 psi	2,636 psi

### A-5.3.2 Pressure

In order to inject CO<sub>2</sub> into the Arbuckle injection interval, the injection pressure at the down hole perforations must be greater than reservoir pressure. The pressure to be applied at the surface (wellhead) will be a function of the bottom hole pressure necessary to inject the desired rate of CO<sub>2</sub> into the Arbuckle, the friction loss generated as the CO<sub>2</sub> is pumped down the tubing and through the perforated completion, and the density of the CO<sub>2</sub> in the tubing. Each of these components that define wellhead pressure will change with time. This short-term small scale pilot injection may utilize variable rates, and the specific injection rates sustainable will be, in part, determined by the CO<sub>2</sub> supply and the pilot scale testing experiments being conducted. The surface pressure will be limited to ensure that the maximum permitted injection pressure is not exceeded. Friction loss will then be highly variable, depending both on the experimental injection rates used, the condition of the perforations over time, and the density/viscosity of the CO<sub>2</sub> injected. The density is a function of both and pressure and temperature, and is expected to range between 46 lb/cu-ft and 59 lb/cu-ft (specific gravity of 0.75 and 0.95) due to temperature and pressure variation in the borehole. As a final variable, pressure rise will be generated in the injection zone as more CO<sub>2</sub> is displaced into the Arbuckle but this will vary depending on recent injected volume, conditions and instantaneous injection rate. At the end of the pilot scale injection, a maximum bottom hole pressure of less than 2,602 psi at a reference depth of 5,050 feet has been projected at possible pilot flow rates from the simulation results. This is less than the 2,636 psi pressure at a depth of 4,910 feet conservatively

estimated as an allowable bottomhole injection pressure using 90% of pressure calculated at depth with a gradient of 0.58 psi/ft.

Wellhead pressures may be variable, but are generally not expected to exceed 800 psi when the effects of variable fluid density along with perforation and tubing friction loss are included in calculations. Bottomhole pressure will be a primary operational issue of concern, and will need to be adjusted based on operations. Since the well is being used for a pilot study, a downhole pressure transducer is planned for monitoring bottomhole pressure. This will be a point of compliance and the PLC or well controller will be programmed to keep bottomhole pressure at 4,930 feet at values of less than a pressure gradient of 0.52 psi/ft. It is noted that the fracture gradient has been estimated as 0.58 psi for this area based on site specific testing.

Without any friction loss included, maximum wellhead pressure could range from 472 to 814 psi assuming that the maximum bottomhole pressure of 2,600 psi was sustained at the perforations and the average specific gravity of fluid in the wellbore ranges from 0.79 to 0.95. Depending on injection rate and final well completion materials, friction loss may require a larger wellhead pressure to sustain the required downhole injection pressure at the perforations. At higher flow rates, at least several hundred psi of tubing friction loss is likely. Although wellhead pressure may vary from 100 to 1,500 psi depending on flow rate, temperature, fluid density and viscosity, the system will typically be operated at wellhead pressures of less than 800 psi.

### **A-5.3.3 Injection Rate**

The planned volume of CO<sub>2</sub> injection is 150 tons per day. However, depending on the formation properties and the need to maintain the CO<sub>2</sub> in liquid state at the pump (which will require a certain minimum pressure based on the temperature), an operating volume of 150-300 tons per day might potentially be injected into the aquifer during batch operations during a 24 hours period in order to achieve the desired daily injection volume. Under these circumstances, the injection will not be continuous but intermittent and instantaneous rate will be higher, as required to sustain required injection pressures. The PLC or well controller will be programmed to keep a running total of the injected CO<sub>2</sub> and will cease operations if the injection exceeds over 300 tons within a 24 hour period. The flow rate however will also be controlled so as not to exceed the maximum bottom hole pressure of 2,636 psi as specified in Table A-5.1.

### **A-5.4 Request for Low-Pressure Annular System**

The Class VI Rule requires that the annulus be filled with a non-corrosive fluid and that the annular pressure between the tubing and the casing be maintained at a pressure higher than the injection pressure. The owner or operator must maintain on the annulus a pressure that exceeds the operating injection pressure, unless the Director determines that such requirement might harm the integrity of the well or endanger USDWs. Conditions at the small-scale Wellington injection site are such that that a casing annulus filled with non-pressurized corrosion resistant fluid will not jeopardize the integrity of the tubing or casing and will satisfy all objectives for monitoring continuous well integrity.

If a positive pressure annulus (>100 psi above maximum wellhead injection pressure) is required, the high annulus pressures (up to 1,600 psi) resulting at the Wellington site have the potential to threaten well integrity and would not be protective of the USDW. Installation of an annular pressure system, where surface annular pressures are 100 psi greater than surface injection

pressures would create the following conditions:

- Annulus pressure of up to 1,600 psi at surface,
- Annulus pressure 3,735 psi at the packer (this exceeds formation frac pressure),
- 1235 psi differential during operations.

Some of the risks associated with the pressured annulus include:

- High differential pressure across casing could cause casing leaks,
- Annulus pressure is greater frac pressure for the entire length of the tubing string,
- High differential across tubing could cause leaks
- High annular pressure could create a micro-annulus outside or damage cement isolation capacity,
- Cycling of pressures will put additional stresses on the cement,
- High annular pressures at the surface create additional hazards for those working near the surface equipment.

It is proposed that KGS #1-28 well be equipped with a low pressure annular system designed around atmospheric pressure. The annular pressure will be continuously monitored at the surface to detect anomalies or changes. The annular pressure will be monitored to evaluate potential leakage through the injection tubing, casing or around the injection packer. Additionally, a set of operating limits or a minimum and maximum pressure range would be employed within a sensitive enough range to react to pressure losses. It is proposed to use annulus pressure monitoring limits set at -5.0 psi to +100 psi. If there is an identified leak in the production casing, fluid would be lost from the annulus and a negative pressure would be observed. If a leak is present in the tubing, a positive pressure deflection would be observed. Anomalies can be suggestive of potential fluid leaks that could develop in either the injection tubing or the production casing or be associated with thermal effects. This operating range is set to reduce false alarms resulting from other variations in operating conditions such as thermal effects and continuously monitor and record values.

If a slowly developing vacuum condition is observed in the annulus indicating a possible annulus leak, the well annulus could be refilled with fluid. Upon stabilized injection conditions (temperature and

rate) being maintained, the continued loss of annulus fluid would indicate a leak from the casing into an under-pressured formation. Upon development of a continued positive annulus pressure trend, the pressure could be bled from the system and the fluid tested for CO<sub>2</sub>. If the positive pressure returned under stable operating conditions (temperature and rate) then a leak would be indicated. The presence of CO<sub>2</sub> gas in the annular fluid would confirm a tubing/packer leak.

### **A-5.5 CO<sub>2</sub> Compatibility with Injection Well Components**

The tubing, casing, packer, and cement of the injection well are all designed to withstand CO<sub>2</sub> service. Similar completions have been used in Kansas and other states. The chemical composition of the injectate should cause no adverse reactions or degradation of the well components for the short nine month duration of injection. The low water content (expected to be less than 50 ppm) and the low temperatures will result in only a mildly corrosive environment. Quarterly monitoring for corrosion using coupon will also provide early warning of a deteriorating environment. The annulus pressure will be monitored daily to detect any leakage from the tubing, casing, or the packer. The annulus fluid will not react negatively with the injected CO<sub>2</sub> should a leak occur in the packer. The CO<sub>2</sub> resistant cement between the injection casing and the borehole reduces the potential for fluid migration into the USDW.

### **A-5.6 Design and Service Life**

Due to the CO<sub>2</sub> resistant properties of the cement and casing, the design life of the well is expected to exceed 10 years. However, the lower segment of the well within the Arbuckle is planned to be plugged at closure within a year of cessation of CO<sub>2</sub> injection. Thereafter, the well will be used in the Mississippian reservoir either as an injection, production, or monitoring well.

### **A-5.7 Demonstration of Mechanical Integrity**

Prior to commencing injection, an Annulus Pressure Test will be conducted at the injection well in order to demonstrate internal mechanical integrity. Testing has already been conducted to provide information necessary to determine the integrity of the casing and casing-cement bond. The casing, injection tubing, and packer will be further evaluated by means of a pressure test after completion

activities are completed and before injection begins. The details of the test are provided in Appendix A-2 (MVA activities). Also, discussed in Appendix A-2 are additional tests that are to be conducted to demonstrate mechanical integrity including daily monitoring of the annular system, and obtaining/analyzing temperature logs during the pre-injection, injection, and post injection phases.

### **A-5.8 Stimulation Plan**

If needed to promote additional injection capacity, standard acid stimulation of the Arbuckle will be completed using standard oilfield practices. Although design parameters may vary depending on conditions encountered, a typical stimulation might involve pumping lease brine as a buffer followed by 1,000 to 2,000 gallons of 15% HCL with iron controls and other additives such as surfactants. This would then be displaced to the perforations by pumping lease brine as displacement fluid. Due to the cooling effect of CO<sub>2</sub> injection, a short soak time might occur, followed by further displacement of the spending acid into the injection interval using additional lease brine. Flushing would continue by pumping 30-40 tons of CO<sub>2</sub>.

### **A-5.9 Annulus Testing**

Prior to starting injection operations, the annulus and tubing/packer integrity will be tested by applying a minimum pressure of 500 psi at the surface to the annulus for a period of 60 minutes. After stabilization, the pressure will be recorded a minimum of every 10 minutes during isolation. Failure of the pressure to remain within five percent (5%) of the starting value would indicate lack of mechanical integrity. At the end of the test, the liquid returned from the annulus will be captured in a container and measured in order to ensure that the entire length of the annulus was tested.

### **A-5.10 Description of Surface Facilities and Injection Operations**

The CO<sub>2</sub> will be delivered to the site in trucks operating daily between the selected CO<sub>2</sub> supplier/vendor and the Wellington site. Each truck will transport approximately 20 tons of CO<sub>2</sub> in liquid state at a pressure of approximately 250 psi and temperature of approximately -10° F.

The surface facilities at the Wellington injection site will consist of a storage tank, a pump, a programmable logic controller (PLC) or suitable equivalent, and flowlines to the wellhead (Figure E-5.2). The injection pump and the controller will be mounted on a skid. The CO<sub>2</sub> will be stored in a pressure vessel adjacent to the injection well (KGS #1-28). The storage tank will be connected to the injection pump skid.

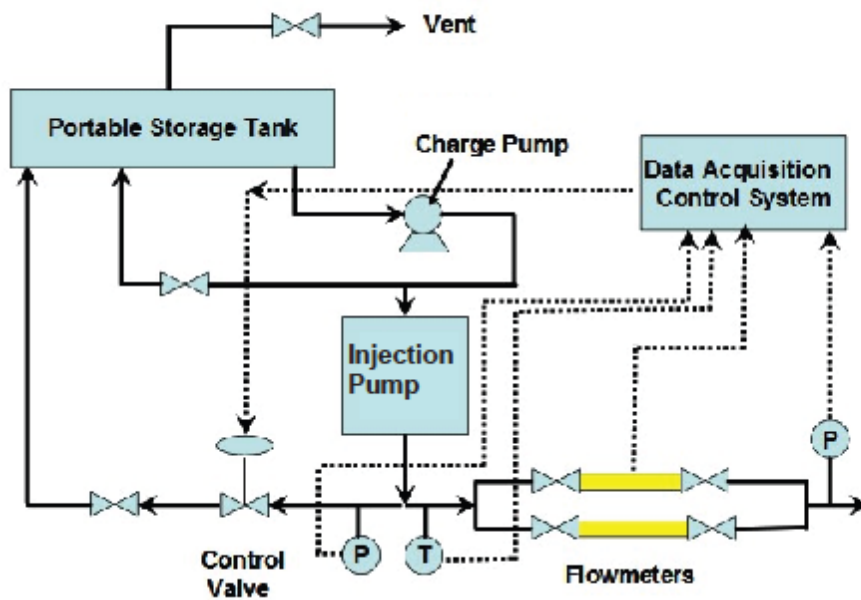

Figure A-5.2—Flow schematic of CO<sub>2</sub> Injection Skid and Portable Storage Tank

The wellhead assembly will consist of a master valve, a swab valve and flow line valves. The well annulus will also have connections and valves necessary for access and testing. Wetter surfaces will be coated, lined or alloys suitable for short-term CO<sub>2</sub> service as available at the time of completion. The bottomhole and wellhead pressures and temperatures will be continuously monitored along with the flow rate at the wellhead and the data fed continuously to the PLC or controller. The controller will manipulate a control valve in the flow line and/or the pump to ensure that the maximum specified flow rate and the bottom hole pressure in the injection well does not exceed the maximum allowable pressure. The CO<sub>2</sub> in the storage tank may experience an increase in pressure as the vessel heats up, which may require occasional venting of the CO<sub>2</sub> in order to relieve the pressure.

The control system will be programmed to initiate shutdown if emergency events occur. All operating data (pressure, temperature, and flow rates) will be digitally stored by the control system.

### **A-5.11 Shut off System**

The PLC or control system used to operate and monitor the well will process flow rate, annulus and injection pressure transducer data. Set points will be programmed to alert operators regarding well conditions of concern. In the event of an emergency, the system will be shutoff. Depending on the event, the system may be either shutoff manually or automatically. Events triggering a shutoff include conditions such as high pressure at the wellhead or bottom hole transducer, exceeding the daily injection volume, or annulus pressure that indicates communication to the injection tubing above a set point based on well operating temperature and pressure. Automatic shutoff will occur if the operational parameters that are being continuously monitored exceed permit limits by the controller cutting the run permissive signal and power to the pump on the skid and closing a valve in the flow-line. Manual shutoff will occur in the event of failure of well mechanical integrity, detection of CO<sub>2</sub> during MVA activities, surface infrastructure damage, etc. The controller will have commercially available alarm capabilities to notify Berexco of a shutdown over cellular network.

## Appendix A-6

### Post-Injection Site Care and Site Closure Plan

#### A-6.1 Introduction

A detailed plan has been developed to satisfy EPA's Class VI requirements for post-injection site care and site closure. The plan addresses the following EPA data/information requirements:

- (i) The predicted position of the carbon dioxide plume and associated pressure front at site closure,
- (ii) The pressure differential between pre-injection and predicted post-injection pressures in the injection zone;
- (iii) A description of post-injection monitoring location, methods, and proposed frequency; (iv) A proposed schedule for submitting post-injection site care monitoring results to the EPA Director,
- (v) The duration of the post-injection site care timeframe and, if approved by the Director, the demonstration of the alternative post-injection site care timeframe that ensures non-endangerment of USDWs.

The monitoring activities presented in the Testing and Monitoring Plan (Appendix A-2, subtask 1.6) will continue during the post-injection phase to meet EPA's post-injection site care (PISC) requirements. Both direct and indirect data will be acquired during the post-injection period. Direct data will be acquired in the injection well and the monitoring wells in Arbuckle Group, Mississippian System, Chase Group beneath the Wellington Formation (USDW), and the Wellington Formation at locations shown in Figure A-2.1. A detailed description of the planned monitoring activities is documented in Appendix A-2. A summary of the post-injection monitoring frequency is provided in Section A-6.2 below.

Upon cessation of injection, the most recently acquired data and modeling results will be reviewed with respect to the most recent PISC plan. Depending on the rate and extent of plume movement observed during the injection phase, the frequency and spatial extent of the monitoring

activities may be modified, and the PISC plan resubmitted to the EPA Director for review and approval. If the preliminary plans do not need to be altered, there will be no modification to the monitoring plan and the well and sampling locations/frequencies will be maintained.

If significant differences are noted between observed and model simulated plume and pressure front are noted during the post-injection period, and if these differences are deemed to have the potential to alter the basis for the permit, the model will be recalibrated and revised plume and pressure projections obtained. The existing post-injection monitoring plan will be reviewed along with the latest model projections and the testing/monitoring plan adjusted and provided to EPA for review in order to ensure accurate tracking of the plume/pressure front in support eventual site closure. If necessary, this process of data acquisition and model refinement/projections may continue in order to determine whether or not the injected CO<sub>2</sub> poses any contamination potential to the USDW. Once a determination of no negative impacts to the USDW is made, an application for site closure will be filed with the EPA Director.

### **A-6.2 PISC Monitoring Activities and Schedule for Submitting PISC Results and Reevaluation**

Various tools will be used to monitor, verify, and account for the injected CO<sub>2</sub>, and the techniques will extend into the post-injection site care time frame. A summary of the monitoring techniques to be employed and the monitoring schedule is presented in Table A-6.1. A detailed explanation of each testing and monitoring method is provided in Appendix A-2 (Testing and Monitoring Plan).

Table A-6.1—Schedule of monitoring activities to be conducted during the PISC phase.

<b>Monitoring Activity</b>	<b>Monitoring Frequency</b>
External MIT (Temperature Log)	Prior to closure
Corrosion	quarterly

Pressure in Arbuckle Injection and Monitoring Wells	Hourly
InSAR	Three measurements every 20 days following cessation of injection, and decreasing incrementally to 12 months interval until closure, should closure last beyond 1 year.
USDW Geochemistry	30-75 days
Mississippian Geochemistry	30-75 days
Arbuckle Geochemistry	30-75 days
3D Seismic Survey	Prior to Closure
CASSM	weekly

The PISC monitoring data along with any updated reservoir modeling results, and any updated PISC and Site Closure plan will be submitted bi-annually to the EPA. In the event that the monitored data is in substantial deviation from the projections, an analysis will be conducted to explain the deviation. If necessary, the reservoir model may be recalibrated to obtain fresh projection of the future plume trajectory and pore pressures. The findings of the reevaluation (including a potentially revised PISC and Site Closure plan) will be submitted to the EPA. Prior to authorization for site closure, a demonstration will be made to the EPA Director, based on monitoring and other site-specific data, that no additional monitoring is needed to ensure that the geologic sequestration project does not pose an endangerment to USDWs.

### **A-6.3 Alternative Post-injection Site Care and Site Closure Time Frame**

The default time frame for post-injection site care is 50 years. However, due to small extent of the CO<sub>2</sub> plume in the subsurface for this pilot-scale project, which will result in pressures in the injection zone to revert to pre-injection levels within 3 months of cessation of pumpgae, KGS/Berexco is requesting to close the site at the end of a one year post-injection period. This proposed post-injection site care time frame will however be re-evaluated and justified to the EPA based on site-specific data obtained the injection and post-injection phases.

The site specific conditions that support a request for early closure are provided below:

- The results of computational modeling of the project indicate that the sequestered CO<sub>2</sub> will not migrate above the primary confining zone and not spread laterally within the injection zone (Arbuckle aquifer) to any natural or artificial penetration that extends into the confining zone other than KGS #1-28 and #2-28, both of which will be constructed to Class VI (injection well) specifications.
- The results of computational modeling indicate that formation pressures are generally not adequate to force the CO<sub>2</sub> - brine mixture within the Arbuckle to penetrate into the USDW. A pressure increase of approximately 327 psi is required for brines in the injection interval to migrate into the USDW. The pressure increase however drops to less than 327 psi within 100 feet of the injection well, which has been constructed per Class VI guidelines as documented. Therefore, there are no existing or abandoned wells through which the Arbuckle brines can be expected to migrate into the USDW. There are also no known or mapped faults within the AoR at the Wellington site through which the brines in the Arbuckle could migrate upward either.
- During operations, the predicted rate of carbon dioxide plume migration is minimal and projections show that the free-phase plume will migrate laterally at a rate of approximately 150 ft per month during the injection period, dropping to 5 feet per year during the next 30 years, and slowing further to less than 1 foot per year during the next 60 years prior to stabilizing. The lateral migration rate of the free phase CO<sub>2</sub> has a maximum spread of approximately 1,750 feet from the injection well at 100 years. There may be some additional movement of the plume beyond 100 years, but this is expected to be minimal and at very low concentrations. Also, the plume is expected to remain confined in the injection interval within the lower Arbuckle and not migrate even into the middle or upper Arbuckle.
- The sequestration processes that were simulated include structural, hydrodynamic, solubility, and residual trapping. The model ignores sequestration due to capillary entrapment and mineralization, and therefore the results are expected to be on the conservative side.

- The hydrogeologic properties of the Arbuckle aquifer Group were derived by means of sophisticated analyses involving the construction of a geomodel utilizing Schlumberger's Petrel modeling software. The data in the geomodel were anchored to core and log data for porosity and permeability as derived at the injection well site (KGS #1-28) and the geologic characterization well (KGS #1-32). Therefore the reservoir model is expected to realistically represent the hydrogeologic properties of the Arbuckle aquifer. However, in order to account for uncertainties, and to obtain conservative results, a set of nine alternative models were derived and used in the simulations by increasing and decreasing the key hydrogeologic properties by 25%. The model based limits on maximum induced pressure and maximum extent of plume migration are based on these alternative models, which ensures some conservatism built into the projections.
- The shales and siltstone in the primary confining zone are expected to provide a tight hydraulic seal with permeabilities at the nano-Darcy level. The lack of hydraulic connection between the injection zone (Arbuckle) and the overlying formations is also documented and confirmed by the geochemical data which indicates vastly different geochemistry in the injection zone and overlying Arbuckle and Mississippian reservoir formations. The Drill Stem Test (DST) data also indicates substantial under-pressurization in the Mississippian Formation that overlies the confining zone (Simpson/Chattanooga/Pierson) suggesting lack of transmissive features in the primary confining zone. Furthermore, the region wide under-pressurization of the Mississippian Formation with respect to the injection zone (Arbuckle aquifer), could only exist in the absence of hydraulic conduits in the confining zone. Even if the CO<sub>2</sub> were to escape from the confining zone, it would be hydraulically trapped in the under-pressurized Mississippian oil reservoir above the confining zone.
- There are no abandoned wells that penetrate the primary confining zone within the AoR. The only existing well within the AoR that penetrates the confining zone is the injection well (KGS #1-28) which was constructed per Class VI specifications. The Arbuckle monitoring well (KGS 2-28), to be located approximately 300 feet northwest of KGS 1-28 and within the AoR, will also be in compliance with Class VI construction requirements. The CO<sub>2</sub> plume is expected to reach this well in approximately 60 days.

- The distance between the injection zone and the base of the USDW is in excess of 4,500 feet. There are multiple confining (shale) zones between the injection zone and the USDW.

#### **A-6.4 Criteria for Demonstration of Alternative Post Injection Site Care Timeframe.**

Care has been taken to ensure acquisition of quality data, and to promote careful processing of the acquired data. The geophysical logs were acquired and analyzed by reputable vendors such as Weatherford and Schlumberger. Laboratory tests to estimate formation properties such as permeability/porosity and rock elasticity/strength were conducted by certified laboratories such as Weatherford Laboratories. Data synthesis and interpretation was conducted by professional staff at KGS who are experts in their field, and professionally certified external consultants.

The geologic and reservoir models developed for the project are based on carefully processed core and geophysical data. The reservoir model is also based on available field data such as injection tests. However, a set of alternative conceptual models were also developed in order to incorporate conservatism in the simulation results. QA/QC measures to be implemented

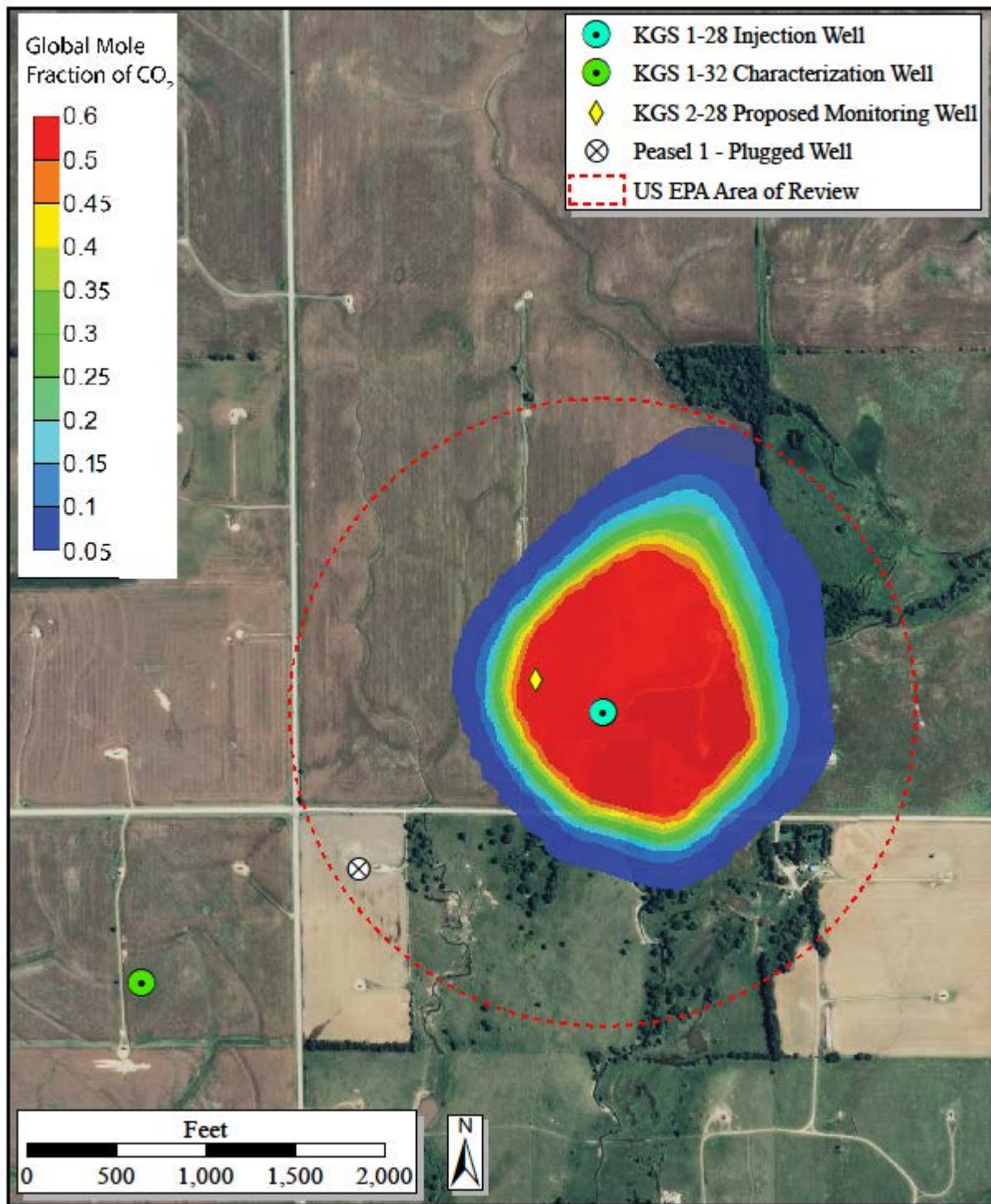

Figure A-6.1—Extent of plume migration at the end of 1 year following cessation of injection for the alternative model resulting in the largest extent of plume migration.

while conducting testing and monitoring activities during the pre-injection, injection, and post-injection phases is documented extensively in Appendix A-2. All analyses and QA/QC for project data meet and will continue to meet the following required standards:

- (i) All analyses and tests performed to support the demonstration will be accurate, reproducible, and performed in accordance with the established quality assurance standards;
- (ii) Estimation techniques will be appropriate and EPA-certified test protocols will be used where available;
- (iii) Reservoir model will be appropriate and tailored to the site conditions, composition of the carbon dioxide stream, and injection and site conditions over the life of the geologic sequestration project;
- (iv) Reservoir model will be reviewed to ensure that it is conformance with newly acquired monitoring and geophysical data;
- (v) Reasonably conservative values and modeling assumptions will be used and disclosed to the Director whenever values are estimated on the basis of known, historical information instead of site-specific measurements;
- (vi) An analysis will be performed to identify and assess aspects of the alternative post-injection site care timeframe demonstration that contribute significantly to uncertainty. Sensitivity analyses will be conducted to determine the effect that significant uncertainty may contribute to the modeling demonstration.
- (vii) The quality assurance and quality control measures will address all aspects of the demonstration.

## A-6.5 Site Closure Activities

Prior to authorization for site closure, KGS/Berexco will submit to the EPA Director for review and approval a demonstration, based on monitoring and other site-specific data, that no additional monitoring is needed to ensure that the geologic sequestration project does not pose an endangerment to USDWs. If the demonstration cannot be made (*i.e.*, additional monitoring is needed to ensure that the geologic sequestration project does not pose an endangerment to USDWs), or if the Director does not approve the demonstration, an updated PISC plan will be submitted to the Director to continue post-injection site care until a demonstration can be made and approved by the Director.

The following activities shall be carried out prior to requesting site closure:

- A 3D seismic survey shall be acquired over the area of approximately one square mile. The new 3D data shall be interpreted and compared with the baseline survey in order to detect the presence of CO<sub>2</sub> outside the expected plume containment area as modeled by reservoir simulation studies.
- The non-seismic MVA data and its analyses conducted during the post-injection phase shall be integrated with the newly acquired 3D seismic data in order to validate the absence of CO<sub>2</sub> outside the containment strata, thus confirming that future leakage risks are minimal to non-existent.
- All monitoring data and other site-specific data shall be accounted for and utilized in the simulation model to demonstrate to the EPA in the form of a report that the pressures have abated, the plume growth has slowed, and that no additional monitoring is needed to ensure that the sequestration project does not pose an endangerment to USDWs. If the EPA does not approve the demonstration, an amended plan will be submitted to the Director for continuing PISC until a demonstration of safe site closure is made and approved by the Director.

KGS/Berexco will notify the EPA Region 7 Director of its intent to close the site at least 120 days prior to the closure date. Any revisions to the PISC and Site Closure plans will accompany the notice. Once the EPA has approved closure of the site, all monitoring wells included in the permit application may be plugged. The Wellington monitoring wells and the Arbuckle geologic characterization well (KGS #1-32) will be plugged following standard industry practices. A site closure report will be prepared within 90 days of closure and submitted to the EPA Director, documenting the following:

- plugging of the injection and monitoring wells,
- location of the sealed injection well on a plat of survey that has been submitted to the local zoning authority. A copy of the plat will also be submitted to the EPA Regional Office,
- notifications of closure to State and local authorities,
- records documenting the nature, composition, and volume of the injected CO<sub>2</sub>,
- all pre-injection, during injection, and post-injection monitoring records,
- KGS/Berexco will submit certifications to the Region 7 Program Director that all geologic sequestration activities have been completed in accordance with the Post-Injection Site Care and Site Closure Plan.

Berexco will record a notation to the property deed on which the injection well (KGS #1-28) was located that:

- property was used for carbon dioxide sequestration,
- name of the agency with which the survey plat was filed, as well as the address of the EPA Region 7 office which received a copy of the plat survey,
- the volume of fluid injected,
- the formation into which the fluid was injected,
- the period over which the injection occurred.

All PISC records will be retained by KGS/Berexco for a period of 10 years following which the records will be delivered to the EPA Director for EPA's retention.